



**NATIONAL OPEN UNIVERSITY OF NIGERIA**

**SCHOOL OF EDUCATION**

**COURSE CODE: SED 323**

**COURSE TITLE: INTEGRATED SCIENCE WORKSHOP**

**COURSE GUIDE**

**SED 323**

**INTEGRATED SCIENCE WORKSHOP**

Course Developer: **Arowolo J.Gbemiga, PhD**

School of Sciences, Department of Integrated Science

Federal College of Education Kontagora, Niger State, Nigeria

Course Writers: Dr. Arowolo J. G.

**NATIONAL OPEN UNIVERSITY OF NIGERIA**

National Open University of Nigeria

Headquarters

14/16 Ahmadu Bello Way

Victoria Island

Lagos

Abuja Annex

245 Samuel Adesujo Ademulegun Street

Central Business District

Opposite Arewa Suites

Abuja

e-mail: [centralinfo@nou.edu.ng](mailto:centralinfo@nou.edu.ng)

URL: [www.nou.edu.ng](http://www.nou.edu.ng)

National Open University of Nigeria 2006

First Printed 2006

ISBN: 978-058-890-6

All Rights Reserved

Printed by ..... For National Open University of Nigeria

SED 323 INTEGRATED SCIENCE WORKSHOP FOR UNDERGRADUATE

## TABLE OF CONTENTS PAGE

Introduction.....	1
What you will learn in this course.....	1
Course Aims.....	1
Course Objectives.....	1-2
Working through the course.....	2
The Course Materials.....	3
Study Units.....	3-4
Presentation Schedule.....	4
Assignment File.....	4
Assessment.....	4
Tutor-Marked Assignments (TMAs).....	4-5
Final Examination and Grading.....	5
Course Marking Scheme.....	5
How to get the most from this course.....	5-8
Tutor and Tutorials.....	8
Summary.....	8

### Introduction

The Course Guide provides a brief description of the course, the course materials to be used by you and how to make use of the materials. Some general guidelines for the time you will likely require to spend on each unit of the course are stated in order to complete it successfully. Similarly, some guidance on your tutor– marked assignments are provided. Detailed information on tutor–marked assignments will be made available to you on a separate Assignment File.

### What You Will Learn In This Course

This course is to intimate Integrated Science teachers at both primary and secondary school levels with information related to tools and their applications in a workshop. As such the overall aim of **SED 323** (Integrated Science Workshop) is to introduce you to the basic tools in Integrated science workshop and their application in workshop constructions.

### Course Aims

The aim of this course is to get you propelled towards identifying basic tools in Integrated Science workshop. Effort will be made in this regard to:

- \* introduce you to the basic tools
- \* help you to develop the skills acquisition in Integrated science
- \* guide you to apply tools in constructions

### Course Objectives

In order to accomplish the aims stated above, the course proposes overall objective. Despite, each unit provides specific objectives foremost at the beginning. It might be expedient that you refer to them in the course of treating a unit to ascertain your progress.

Listed below is a set of the general objectives of the course.

It is expected that having successful completed the course, you should be able to:

1. Identify basic tools in Integrated Science workshop

2. Acquire basic skills in shaping objects
3. Apply tools in workshop constructions

### **Working Through The Course**

For you to complete this course, you need to read through each unit of this study material in addition to other relevant materials, which may be provided by the National Open University of Nigeria. Each unit provides self- assessment exercises for this course and at interval of time in the course you would be required to submit tutor marked assignments for assessment purposes. At the end of the course, there is a final examination. The course is planned in such a way as to span though about a total of 17 weeks to complete. All the components of the course are listed below; so also you will find what you have to do and how you should allocate your time to each unit in order to complete the course on time and successfully.

Be advised that you avail yourself the opportunity of attending the tutorial sessions at the appropriate time where you will have the opportunity of comparing knowledge with your peers.

### **The Course Materials**

Major components of the course are:

- 1.0 The Course Guide
- 2.0 Study Units
- 3.0 References
- 4.0 Assignments
- 5.0 Presentation Schedule.

### **Study Units**

There are fourteen study units listed under three modules in this course. They are as follows:

#### **Module 1 Basic Tools**

- Unit 1: Basic carpentry tools
- Unit 2: Glass work tools
- Unit 3: Sign writing tools
- Unit 4: Metal work tools
- Unit 5: Electrical/electronic work tools

#### **Module 2 Skills acquisition**

- Unit 1: Entrepreneurship
- Unit 2: Skill development
- Unit 3: Skill acquisition models
- Unit 4: Importance of skills acquisition

#### **Module 3 Application of Tools**

- Unit 1: Construction of wooden and glass apparatus
- Unit 2: Sign writing
- Unit 3: Metal works
- Unit 4: Construction of simple electronics
- Unit 5: Safety in Integrated science workshop

Each unit consists of table of contents, introduction, statement of objectives, contents, conclusion, summary, tutor marked assignment and references. There are activities written at every point which are meant to assist you in achieving the stated objectives of the individual units and of the course.

### **Presentation Schedule**

Your course materials will give you important dates for the early and timely completion and submission of your TMAs and for attending tutorials. You are to remember that you will need to submit all your assignments by the stipulated time and date. You should avoid lagging behind in your work.

### **Assignment File**

There are **thirteen** assignments in this course. That is one assignment per unit. These are designed to ensure that you have actually understood each of the units. In this file, you will find all the details of the works you must submit to your tutor, for marking. Remember your assignments are as important as the examinations as they carry weightings of 30% for undergraduate.

### **Assessment**

Two major methods will be used to assess the course. The first major method is through assignments while written examination will be the second. The course material had been prepared to assist you to do these assignments. You are also expected to use information and knowledge from the recommended text at the end of each unit. The assignment will carry 30% of the total marks for the undergraduate students. Final examinations of about two hours duration will be written at the end of the course and this will also carry 70% of the total marks for the undergraduate students.

### **Tutor-Marked Assignments (TMAs)**

The TMA is a continuous assessment component of your course. It accounts for 30% of the total score. You are required to submit at least four (4) TMAs before you are allowed to sit for the end of course examination. The TMAs would be given to you by your facilitator and you are to return them to same as and when due.

Assignment questions for the units in this course are contained in the assignment file. You will be able to complete your assignment from the information and materials contained in your reading your study units and, references. However, it is desirable to demonstrate that you have read and researched more into other references, which will give you a wider view point and may provide a deeper understanding of the subject.

Make sure that each tutor-marked assignment reaches your facilitator on or before the deadline given in the presentation schedule and assignment file. If for any reason you cannot complete your work on time, contact your facilitator before the assignment is due to discuss the possibility of an extension. Extension will not be granted after the due date.

### **Final Examination and Grading**

The final examination for **SED 323** will be for two hours duration and will carry 70% of the total marks for undergraduate students. The examination will consist of questions, which

reflect the type of self testing, practice activities and tutor-marked assignments/problems you have encountered previously. All areas of the course will be assessed.

You may wish to form a discussion group of considerable numbers of your colleagues and practice or discuss the activities and assignments written in each unit before the examination period.

### Course Marking Scheme

Assessment	Category of Students	Scoring	Marks
Assignment 1-13	3 for Undergraduate	each counts for 10 marks	30 marks
Final Examination	Undergraduate		70 marks
<b>TOTAL</b>			<b>100% of Course Marks</b>

### How To Get The Most From This Course

(1). In distance learning, the study units replace the university lecture. This is one of the advantages of distance learning. You can read and work through specially designed study materials at your own pace, and at a time and place that suits you best. Think of it as if you are reading the lecture instead of listening to the lecturer. In the same way a lecturer might give you some reading to do, the study units tell you when and what to read. You are provided with exercises, to do at appropriate points, just as a lecturer might give his/her student an in-class activity.

(2). Each of the study units follows a common format. The first item is an introduction to the subject matter of the unit, and how a particular unit is integrated with the other units and the course as a whole. Next to this is a set of learning objectives. These objectives allow you to understand what you should be able to do, by the time you have completed the unit. These learning objectives are meant to guide your study. The moment a unit is finished, you must go back and check whether you have achieved the objectives. If this is made a habit, then you will significantly improve your chances of passing the course.

(3). The main body of the unit guides you through the required reading from other sources. This will usually be either from your references or from a reading section.

(4). Self activities are interspersed throughout the units, working through these activities will help you to achieve the objectives of the unit and prepare you for the assignments and the examination. You should do each self activity as you come to it in the study unit. (5). The following is a practical strategy for working through the course. If you run into any trouble, telephone your tutor or visit the study centre nearest to you. Remember that your tutor's job is to help you. When you need assistance, do not hesitate to call and ask your tutor to provide it.

### Read this Course Guide thoroughly, it is your first assignment

(1). Organize a Study Schedule- Design a 'Course Overview' to guide you through the Course. Note the time you are expected to spend on each unit and how the assignments relate to the units. Important information, e.g. details of your tutorials, and the date of the first day of the Semester is available at the study centre. You need to gather all the information into one place, such as your diary or a wall calendar. Whatever method you choose to use, you should decide on and write in your own dates and schedule of work for each unit.

- (2). Once you have created your own study schedule, do everything to stay faithful to it. The major reason that students fail is that they get behind with their course work. If you get into difficulties with your schedule, please, let your tutor know before it is too late for help.
- (3). Turn to Unit 1, and read the introduction and the objectives for the unit.
- (4). Assemble the study materials. Information about what you need for a unit is given in the 'Overview' at the beginning of each unit. You will always need both the study unit you are working on and one of your text books on your desk at the same time.
- (5). Keep an eye on the course information that will be continuously posted to you. Visit your study centre whenever you need up to date information.
- (6). Well before the relevant due dates (about 4 weeks before due dates), visit your study centre for your next required assignment. Keep in mind that you will learn a lot by doing the assignment carefully. They have been designed to help you meet the objectives of the course and, therefore, will help you pass the examination. Submit all assignments not later than the due date.
- (7). Review the objectives for each study unit to confirm that you have achieved them. If you feel unsure about any of the objectives, review the study materials or consult your tutor. When you are confident that you have achieved a unit's objectives, you can start on the next unit. Proceed unit by unit through the course and try to space your study so that you can keep yourself on schedule.
- (8). When you have submitted an assignment to your tutor for marking, do not wait for its return before starting on the next unit. Keep to your schedule. When the Assignment is returned, pay particular attention to your tutor's comments, both on the tutor- marked assignment form and also the written comments on the assignments, consult your tutor as soon as possible if you have any questions or problems.
- (9). After completing the last unit, review the course and prepare yourself for the final examination. Check that you have achieved the unit objectives (listed at the beginning of each unit) and the course objectives (listed in the Course Guide).

### **Tutor and Tutorials**

Tutorials shall be provided in support of this course. You will be notified of the dates, times and location of these tutorials as well as the names and phone number of your facilitator, as soon as you are allocated a tutorial group.

Your tutor or facilitator will mark and comment on your assignments, keep a close watch on your progress on any difficulties you might encounter and provide assistance to you during the course. Submit your tutor-marked assignment to your tutor before the due date; at least two working days are required. They will be marked by your tutor and returned to you as soon as possible.

Do not hesitate to contact your facilitator on telephone, e – mail and discuss problems if you need assistance. The following might be circumstances in which you would find help necessary. Contact your facilitator if:

1. You do not understand any part of the study units or the assigned readings.
2. You have difficulty with the self-test or activities.
3. You have a question or problem with an assignment, with your tutor's comment or with the grading of an assignment.

You should try your best to attend the tutorials. This is the only chance to have face to face contact with your course facilitator and to ask questions which are answered instantly. You



can raise any problem encountered in the course of your study. To gain much benefit from course tutorials prepare a question list before attending them. You will learn a lot from participating in active discussion.

### **Summary**

**SED 323** intends to introduce you to workshop practices in Integrated science. The course will expose you to identifying basic tools available in Integrated science workplace. The course will also attempt to lead through skills acquisition as well as the applications of basic tools in workshop constructions. Out of the three domains of learning, the psychomotor aspect takes precedence over others (cognitive and affective), in this course. You are as a result encouraged to make use of your body parts especially your hands, eyes, ears, etc to achieve the objectives of the course. You could also be required to possess a few basic tools to practice with on a regular basis in order to perfect the skills. Having gained the experiences which the course is meant to offer, you will be able to attempt such questions as:

- (i) What is a tool?
- (ii) What specific skills are required in Integrated science workplace?
- (iii) What specific tools are needed for a particular construction work?
- (iv) How can a tool be applied in construction work

### **TABLES OF CONTENTS PAGE**

#### **Module 1 Basic Tools**

- Unit 1: Basic carpentry tools
- Unit 2: Glass work tools
- Unit 3: Sign writing tools
- Unit 4: Metal work tools
- Unit 5: Electrical/electronic work tools

#### **Module 2 Skills acquisition**

- Unit 1: Entrepreneurship
- Unit 2: Skill development
- Unit 3: Skill acquisition models
- Unit 4: Importance of skills acquisition

#### **Module 3 Application of Tools**

- Unit 1: Construction of wooden and glass apparatus
- Unit 2: Sign writing
- Unit 3: Metal works
- Unit 4: Construction of simple electronics
- Unit 5: Safety in Integrated science workshop

# **MODULE 1 BASIC TOOLS**

## **INTRODUCTION**

Mankind from the outset has been curious about the materials within the environment. In order to harness these materials for their best use, mankind has unconsciously or consciously invented a number of tools/implements from prehistoric era. We have heard and read about the forceful scratching of two stones together to ignite dry grasses to make fire, breaking of rocks to obtain a sharp edged part for cutting and several similar others. The skills for inventing tools have developed over time and has ever become more sophisticated up to date. Today, a lot of tools have been invented as much as works of life have dictated. This module one is basically meant to introduce you to the basic tools commonly present for use in Integrated science workshop. In view of this, the course material of this module one is divided into five (5) units as follows:

Unit 1: Basic carpentry tools

Unit 2: Glass work tools

Unit 3: Sign writing tools

Unit 4: Metal work tools

Unit 5: Electrical/electronic work tools

## **UNIT 1 BASIC CARPENTRY TOOLS**

### **CONTENTS**

1.0 Introduction

1.1 Objectives

1.2 Main Contents

1.2.1 Meaning of tools

1.2.2 History of tools

1.2.3 Carpentry tools

1.3 Conclusion

1.4 Summary

1.5 Tutor Marked Assignment

1.6 References/Further Readings

### **1.0 INTRODUCTION**

This unit will deal with basic tools. The definition of tools will be learnt. Basic tools in carpentry workshop will identified as well as their component parts. You will as well learn how to sketch the shape of the tools.

## **1.1 OBJECTIVES**

After studying this unit, you should be able to:

1. define a tool
2. identify/name basic carpentry tools
3. sketch basic carpentry tools.

## **1.2 MAIN CONTENT**

### **1.2.1 MEANING OF TOOLS**

Human kind acquired a far reaching ability to manipulate the physical environment. Human beings have succeeded in creating useful things and modify the universe. Skills have helped humans survive and flourish. Every culture has customs that guide them on how the members manipulated the physical components of the environment. Such manipulation is referred to as technology.

The product of manipulation or modification of physical environment by humans is known as an artifact. Specific collections of artifacts are associated with a given society. This are described as the society's material culture. Tools constitute one kind of artifacts which have on the one hand been modified and on the other can be used to modify or more other things. Tools are important aspect of material culture in that they reflect how a society works as well as lives and the way the society can alter the physical environment

### **SELF ASSESSMENT 1**

What is a tool?

A tool is defined as any instrument which an artisan uses to perform a work tools are the basic means through which mankind control and manipulate their physical world. Most hand tools are small manual instrument traditionally operated by the muscular strength of the user. A machine tool however is usually a power driven mechanism. There are two main kinds of tools viz: wood working and metal working tools.

### **SELF ASSESSMENT 2**

Differentiate woodworking and metalworking tools.

Woodworking tools are the tools of carpenters and the cabinet constructors. Woodworking is a means of forming and shaping of wood to make useful and decorative objects. There exist five main stages in wood working which include in order

- i. planning and design

- ii. cutting
- iii. drying
- iv. fastening and
- v. sanding and finishing.

Metalworking tools are tools employed by machinists and tool makers. Such tools require much greater precision and must be very accurate. Machine tools produced by machining operations and metal parts include lathes, milling machines, shapers and grinders.

### 1.2.2 HISTORY OF TOOLS

Mankinds have recorded series of observations on nonhuman animals which indicate that higher primates occasionally make and use simple tools. Chimpanzees for instance can modify sticks and stones to process food and to defend themselves. Prehistoric people practiced a number of trial and error on rocks and sticks of certain shapes that were used to carry out different works which ordinarily cannot be done with their bare hands. People of this age nonetheless improved the natural stones they used.

### SELF ASSESSMENT 3

What innovations were effected on tools by man?

Stone Age people shaped natural stones into knives, hatchets and hammers as well as attached wooden handles to them. They equally developed a drill for drilling soft stone and wood. During the Bronze Age new tools were developed which include tongs for holding hot objects. Likewise agricultural civilizations prompted modern man to venture into yet some other new tools such as hoe and simple plow. In the course of time humans were able to learn how to work iron and steel, they succeeded in developing stronger, shapers and more durable tools.

### 1.2.3 CARPENTRY TOOLS

Carpentry is simply a process of building and repairing structures. It combines all types of work carried out by carpenters. This includes the construction of buildings and their parts. Carpentry as well involves the design and assembly of cabinets, furniture and their relatives. Most carpenters work with wood but some could as well work with metals and plastics

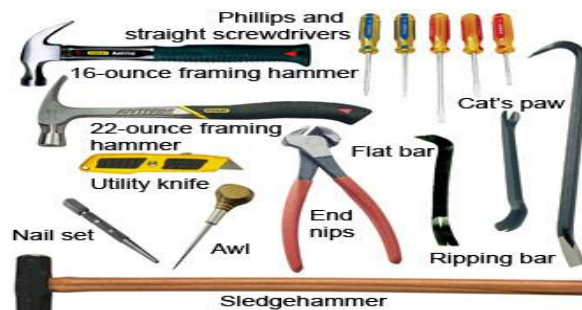

## **SELF ASSESSMENT 4**

Explain the two kinds of carpentry

Carpenters ought to understand how to use various hand tools. There are two types of carpentry which are: rough and finish carpentries. Rough carpentry is the extreme wood working on a building. It involves the assemblage of frameworks of buildings and the placement of covering called sheathing and siding on the structures.

The finish carpentry includes the various forms of interior wood working. This aspect of carpentry covers hanging doors and windows application of wood trim, installing paneling and laying floors.

## **SELF ASSESSMENT 5**

Identify the tools in woodwork constructions.

The tools commonly used by carpenters and cabinet makers include the following:

1. Measuring tools like the rule for measuring lengths
2. The squares and protractors for measuring angles
3. The compasses for making circles and arcs
4. Vices and clamps which are used to hold materials in place while specific operation is effected e.g. shaping.
5. Shaping tools include: saws, chisels, planes, files and boring bits
6. Other common tools are hammers, hatchets, screw drivers and pliers

## **SELF ASSESSMENT 6**

Sketch the following carpentry tools: (i) rule (ii) square (iii) brace and bits (iv) saw (v) plane (vi) hand sander (vii) clamp (viii) screw driver (ix) clawed hammer (x) file

## **1.3 CONCLUSION**

This unit has exposed you to basic tools used for work. You have also learned about the history of tools. You can now identify and sketch some tools used in a carpentry workshop.

## **1.4 SUMMARY**

You have learned that a tool is any instrument used to do work in this unit. Two kinds of tools have been listed to include wood working and metal working tools specific steps in wood working were also made known. The unit as well reveals the historic development of tools by man from Stone Age to date. Finally, you have learned that there are rough and finish carpentry in addition to identifying a few carpentry tools.

### **1.5 TUTOR MARK ASSIGNMENT**

1. Who is a carpenter?
2. Identify/ name the specific materials a carbine worker add to the furniture finishing

### **1.6 REFERENCES/ FURTHER READING**

Encyclopedia Americana International Edition (2006). Danbury, connect cut: Scholastic library publishing, Inc. (26)

The New Encyclopedia Britannica (1999). Chicago (19).

The World Book Encyclopedia, (2004). World Book Inc. Chicago 233 North Michigan Avenue IL60601. (3)

The World Book Encyclopedia, (2004). World Book Inc. Chicago 233 North Michigan Avenue IL60601. (19)

The World Book Encyclopedia, (2004). World Book Inc. Chicago 233 North Michigan Avenue IL60601. (21)

## **UNIT 2 GLASS WORK TOOLS**

### **2.0 INTRODUCTION**

You will learn in this unit the basic tools in glass forming techniques to produce different shapes of glass wares. You will also identify the various tools used to work on glass.

### **2.1 OBJECTIVES**

After studying this unit, you should be to:

- i. identify glass ware
- ii. explain the techniques in glass forming
- iii. list the tools used in glassworks.

### **2.2 MAIN CONTENT**

#### **2.2.1 GLASS**

A glass is an inorganic hard non-crystalline, clear and transparent substance. The atoms of the substance are arranged at random unlike the regular patterns of crystals which characterizes its glassy nature. Glass is composed of three major substances which include silica sand (silicon dioxide), soda ash (sodium carbonate) and limestone (calcium carbonate). Glass chemical formulations run into a thousand with unique combination properties.

#### **SELF ASSESSMENT 1**

State the general properties of glass.

The common properties of glass include the following:

- i. Glass is hard
- ii. Glass is perfectly elastic, brittle and non conductor of electricity
- iii. Glass is chemically stable
- iv. Glass is known to be on amorphous solid
- v. When heated, glass soften to a fluid and as it cools, it thickens to rigidity

#### **SELF ASSESSMENT 2**

Outline the (i) chemical, (ii) electrical, (iii) mechanical, (iv) optical and (v) thermal properties of glass

- (i) Chemical properties of glass

- Glass is relatively of high resistance to attack (e.g. corrosion) by most chemical reagents (e.g. Hydrofluoric acid, hot concentrated alkalis and superheated water).

(ii) Electrical properties of glass

- Glass displays insulation resistance to the passage of electrical current through it
- Glass shows a dielectrically constant which measures the ability of a glass to store electricity in an electrical field, eg, glass capacitors.
- Glass exhibits dielectric loss which is a measure of the amount of energy that an electrical wave will lose by absorption when passing through a glass, especially applicable in electronics.
- Glass has dielectric strength which is otherwise known as breakdown voltage. This is a measure of the voltage that can be applied across a piece of glass before the glass breaks down and let spark jump between the electrodes.

(iii) mechanic properties

- Glass behaves perfectly elastically when stressed up to the point of fracture.

(iv) Optical properties

- Most glass is transparent.
- Glass transmits almost all the light rays that strike it with small quantity reflected and absorbed.
- Glass can bend light waves as they pass through it. This phenomenon is called refraction which is applied in lenses.

(v) Thermal properties

- Most glass has lower rate of thermal expansion than steel.
- Glass shows low thermal conductivity and high emissivity.

## 2.2.2 KINDS OF GLASS

Glass may be considered to be a material that can break easily e.g. window glass or eye glasses. Glasses are not made of the same components. Glass is grouped into five kinds:

- i. **Flat glass** used in windows, mirrors, room divider etc.
- ii. **Glass containers** for packaging food, medicines, chemical cosmetics etc
- iii. **Optical glass** used in eyeglasses, microscopes, camera lenses etc
- iv. **Fiber glass** used like wood to make take, cloth, mats etc.
- v. **Specialty glasses** used for specific purposes.



## SELF ASSESSMENT 3

Identify 5 different kinds of specially glasses and the uses

- i. Laminated safety glass: this is a sandwich made by combing alternate layers of flat glass and plastics and it is used in situations when broken glass might cause serious injuries eg, automobile windscreen.
- ii. Bullet- resisting glass: this is a thick, multilayer laminated glass. This is used to stop bullets at close range as found in bank teller windows, windscreen for military tanks, aircraft and some automobiles.
- iii. Tempered safety glass: this is a simple piece given a special heat treatment. It is stronger than most ordinary glasses. It is hard to break. Examples are used for glass doors, side and rear windows of automobiles and basket ball boards.
- iv. Glass tubing: this is made from different kinds of glass and of different sizes. It is used to make fluorescent light, neon signs, glass piping and chemical apparatus.
- v. Laboratory glassware: this is made from heat resistant glass to withstand severe heat shock and resistant to chemical attack. They are mostly used in laboratory experiments eg, beakers, flasks, test tubes, burette etc.

### 2.2.3 GLASS MAKING

The basic techniques and methods of forming glass have undergone some refinement these modern days. The basic steps involved included mixing, melting, forming and annealing. Some raw materials are required in glassmaking, e.g, Silica plus oxides of boron, aluminum, sodium, potassium, calcium, lead, etc. The raw materials could be in the form of carbonates, nitrates or crystalline substances, and Sand which must be in its purest state.

1. Mixing: railroad cars bring raw materials to glass plants which are stored in large silos. These materials are weighed and mechanically blended in proper proportions. This mix of ingredients is known as **batch** to which **cullet** is added by the manufacturer. Cullet can be any of recycle or waste glasses. The batch is loaded into the furnace after mixing in batch cars or hoppers or on conveyor belts.
2. Melting: the mixture of batch melts at 1425°C to 1600°C. Melting is carried out in refractory pot in the past; nowadays, large quantities of glass are made in furnace called day tanks or continuous tanks.
3. Forming: there are four means of shaping glass. These include: blowing, pressing, drawing and casting.
4. Annealing: this is a process that removes the stresses and strains remaining in glass after shaping. This is done by reheating the glass and gradually cooling it based on planned time and temperature schedule.

## SELF ASSESSMENT 4

What is glass blowing?

Glass blowing is a practice of shaping a mass of glass that has been softened by heat. The practice involves blowing air through a tube dipped in the molten glass. Glass blowing was invented by Syrian craftsmen in Sidon, Aleppo and Hama in the 1<sup>st</sup> Century BC. A glassworker blows gently into the pipe until the molten glass bulges out and forms a hollow bulb inside a mold. This bulb can be squeezed, stretched, twisted and cut. The worker reheats the glass from time to time to keep it soft while forming the desired shape. Two types of molds used in blowing glass are paste mold and hot-iron mold. The molds may be hinged to prevent removal of the blown ware. Having achieved the shape required, the blown glass is carefully removed from the pipe by losing the hinge.

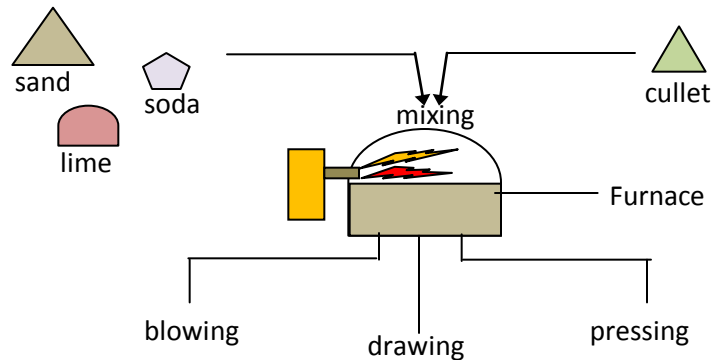

### 2.2.4 TOOLS IN GLASSWORK

The major tools required in glass work include blowpipe or tube, the punty or pontil, bench, marver, blocks, jacks, paddles, tweezers, paper and a variety of shears. These are the tools used by glassblower, glassmiths or gaffer in forming glass.

### 2.3 CONCLUSION

This unit has exposed you to the meaning of glass. You have also learned different kinds of glass, the process of glass forming and the tools required of a glass worker.

### 2.4 SUMMARY

This unit has given the meaning of glass to be an inorganic substance which is hard but transparent or translucent. The unit also identified the properties of glass chemically, electrically, mechanically, optically and thermally. Five different kinds of glass were identified to include: flat glass, glass container, optical glass, fiber glass and specialty glass. The unit equally explained the process of making glass with particular reference to glass blowing and the tools required in glasswork.

## **2.5 TUTOR MARKED ASSESSMENT**

(1). How can glass be formed through casting?

## **2.6 REFERENCES/FURTHER READINGS**

Encyclopedia Americana International Edition (2006). Danbury, connect cut: Scholastic library publishing, Inc. (12)

The New Encyclopedia Britannica (1999). Chicago (5).

The World Book Encyclopedia, (2004). World Book Inc. Chicago 233 North Michigan Avenue IL60601. (8)

## UNIT 3 TYPOGRAPHY TOOLS

### 3.0 INTRODUCTION

This unit will deal with meaning of typography, you will as well learn the basic tools for panting work and the for sign writing. You will appreciate the possibility of producing different colours for your instructional material without stress in order to make your class more lively and your teaching more interesting and motivating.

### 3.1 OBJECTIVES

After studying this unit, you should be able to:

- (i) identify typefaces.
- (ii) identify as well as mix colours.
- (iii) produce a colour wheel
- (iv) list the tools for artwork

### 3.2 MAIN CONTENT

#### 3.2.1 TYPOGRAPHY

It is conventional that when an instructional material is produced, it should bear some labels. These labels are writing in letters. The task of the writer is to make the letters easy to read and aesthetically pleasing. The art of design and selection of letter forms used to make a page of printed text is called typography. A typographer is someone who specializes in letter forms. The basic aspect of typography of interest is the highly standardized set of characters inherited from handwriting by the Western World. In sign writing, typefaces are used. A typeface is a set of lettering designed and supported to be used together in a given expression of ideas/ the Western typefaces revolve around three main kinds namely: Roman, Italic and Black letter. All these typefaces are derived from a kind of typeface called Script.

#### SELF ASSESSMENT 1

What are the major features of the three main typefaces?

Four basic typefaces which are: The Roman, The Italic, Sans Serif and The Black letter are identified as distinct in typography.

- (1) Roman types – have small finishing strokes called serifs that extend from the main strokes of the letters. This type includes few designs called black letter and uncial. Black letter designs have highly decorative letters with thick and heavy lines while uncial designs look like rounded capitals. The present day roman style type was perfected by a French printer, Nicolas Jenson in 1470. Popularly used Roman type include Times Roman, Garamond, Bodoni, e.t.c Examples:

- (a) **This Unit Is All About Typography** – Times Roman

(b) **This Unit Is All About Typography** – Garamond

- (2) Italic types – these letters are slanted. They are often used to emphasize a word or group of words, e.g the botanical names of plants in botany or scientific names of some animal species in Biology. When used, they attract attention on printed works. This shows why they are mostly used in titles of books, magazines or newspapers. Among the italic types are: future and Baskerville italics. Examples:

*(a) This Unit Is All About Typography - Italics*

- (3) Sans-serif types – these are types without serifs ('sans' means without in French). This typeface is often used for advertisements, heading and texts. Popular among this type are univers, Helvetica, futura etc.

**(a) This Unit Is All About Typography – Futura**

- (4) Script types – these are types that resemble most handwriting. Most of the small letters (lowercase) of scripts styles are joined together when writing. It is used widely in advertisement, examples include: brush, Kaufmann and bank scripts.

*(a) This Unit Is All About Typography – Brush*

Technology has made things simple to come by today however, this is because the computer stores instructions for forming any character in a font. The laser contained in the computer provides the means by which the machine uses the stored instructions to create images of type desired.

### **3.2-2 BASIC TOOLS FOR PAINTING**

Painting according to Oxford Advance Learner's Dictionary is the art or act of using paint to produce pictures. It is the act of putting paint (coat) onto the surface of the objects, walls, etc. Similarly, paint is a liquid that is put on surfaces to give them a particular colour. Mostly, artists arrange colours on surface in ways that express their ideas/impressions about people, religion or the world. Paintings have been known to create great values for humanity as well as provide people with pleasure and information. Although, some artists paint basically to satisfy themselves in enjoyment or self expression or to choose a specific subject, painting can as well teach.

### **SELF ASSESSMENT 2**

List the (i) material and (ii) tools required in painting.

- i. The materials needed in painting basically are: the paint, solvent (water, gasoline) board, masking tape, etc.

- ii. The tools required for painting includes: painting brushes, painting rollers, sprayer gun/paint pads, pencils, etc.

### **3.2.3 BASIC TOOLS IN SIGN WRITING**

Writing, usually as a career provides personal rewards. Writing enables people to express their views and to entertain, inform or influence other people. Two kinds of writer have been identified to include: staff writers and free lance writer. Staff writer are professional as newspaper reporters or columnists or technical writers who express the complex ideas of engineers and scientists in words that a non expert can understand. Free lance writers are known for their works on fiction and nonfiction expressions such as in drama, poems, screenplays, shorts stones and articles. The teacher also develops this habit in his/her teaching career. Sign writing is simply the act of selecting desired letters to express an intension, a topic or a direction or notice and the likes in the classroom interactions.

### **SELF ASSESSMENT 3**

What are the basic tools required in sign writing?

The basic tools required in sign writing may include: a ruler, pencil, cardboard, a board, paint, writing brush, foam, masking tape, etc.

### **3.2.4 COLOUR**

Colour is viewed as the appearance that things have which results from the way in which they reflect light (Oxford Advanced Learner's Dictionary). Colour fills the universe with beauty. There are two categories of colour which are: light and pigment.

Light is a form of energy that behaves like waves. Such waves have a range of wavelengths. Different wavelengths of light appear to us as different colours. However, the white light of the sun contains all wavelengths in the same proportions. When a beam of light rays from the sun passes through a prism for instance, different wavelengths are bent at different angles. These results in a band of colours as in the rainbow and are referred to as visible spectrum.

For human beings to recognize colour, there are cone cells in the retina that are sensitive to wavelengths of rays of light. Other animals like Apes, Monkeys, some birds and species of fishes also posses colour vision like man.

Colour can produce different effects to vision such colour vision effect include: chromatic adaption and chromatic induction or simultaneous contrast.

### **SELF ASSESSMENT 4**

What are the methods of colour production?

There are different ways of producing colour as stated below.

1. **Mixing colourants:** colorants are substances that give colour to such materials as ink, paint, crayon and chalk. The fine powders of colourants are mixed with liquids, wax or other substances to make them easier to apply to objects. Colourants are categorized into dyes and pigments. When two different colourants are mixed a third colour is produced by subtracting some wavelength of light, eg, mixing blue pigment with yellow pigment to produce green pigment.
2. **Mixing coloured lights:** lights of different colours may be projected together onto a screen in which case they blend and form new colours. The production of new colours occurs by adding light of different wavelengths. This is why coloured light mixtures are called additive colour mixtures or colour by addition.
3. **Colour triangle:** the primary colours in light are red, green and blue. Any two of these light colours can be mixed to result into white light and this are said to be complementary, when red and green lights are mixed for instance they produce yellow light, blue mixed with green lights forms blue-green light, while blue and red lights form purple light. Combing all the three primary light colours usually produce white light. It is this knowledge that makers of TV applied in colour television. The pictures viewed on the screen are created by additive mixtures of the three primary light colours.

## SELF ASSESSMENT 5

Create a colour triangle

A colour triangle is produced below:

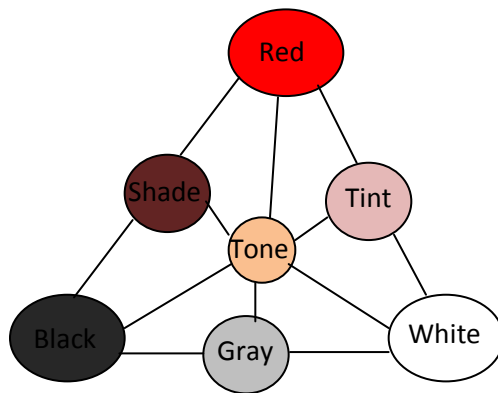

Source: World Book illustration

## SELF ASSESSMENT 6

What is colour harmony?

A colour harmony is expressed when neighbouring colours have a pleasing effect. This is what dictates the choice of people on items in the market. A colour circle/wheel displays the relations among colours. It helps in choosing harmonious colour combinations. A colour wheel consists of a range of colours in the form of a circle running from red through other colours of the spectrum and back to the starting red.

### **SELF ASSESSMENT 7**

State the characteristics of colour.

There are three major characteristics of colour which include:

- (1) Hye: this is the characteristic that gives a colour the name known for it, eg, red, blue, violet, etc.
- (2) Lightness: this is a measurement of the amount of light reflected from a coloured object.
- (3) Chroma: this is a measurement of the saturation concentration of a colour, eg, a teaspoon of red paint powder mixed with a teaspoon of water produces paint of deep red colour.

### **3.3 CONCLUSION**

In this unit, you have learned different typefaces, painting and colours. You also learned the tools required for painting and sign writing. You as well learned how to mix colours to obtain another.

### **3.4 SUMMARY**

This unit has given the meaning of typography as an art of design and selection of letters used to make a printed text. The unit also gave the typefaces as: roman, italics, sans-serif and script. You were exposed to basic painting tools and sign writing tools. This unit made you to understand that colour is the appearance that things have which results from their ability to reflect light. It is possible for you to conveniently mix colour either light or pigment to meet specific demand and desire. The unit lead you to understand what colour harmony is and stated the characteristics of colour.

### **3.5 TUTOR MARKED ASSESSMENT**

What is typography?

### **3.6 REFERENCES/FURTHER READING**

Oxford Advanced Learner's Dictionary International Students Edition, 7<sup>th</sup> edition (2005).  
Oxford: University Press.



The World Book Encyclopedia (2004). World Book Inc. Chicago: 233 North Madigan Avenue, 1160601 (4).

The World Book Encyclopedia (2004). World Book Inc. Chicago: 233 North Madigan Avenue, 1160601 (15).

The World Book Encyclopedia (2004). World Book Inc. Chicago: 233 North Madigan Avenue, 1160601 (19).

The World Book Encyclopedia (2004). World Book Inc. Chicago: 233 North Madigan Avenue, 1160601 (21).

The New Encyclopedia Britannica. Chicago : (12).

## **UNIT 4 METAL WORK TOOLS**

### **4.0 INTRODUCTION**

You will learn from this unit what metal is, the properties of metals and some uses. A brief historical background of metal will be learned. You will be exposed to a brief experience on geometry and tools in metal workshop.

### **4.1 OBJECTIVES**

After studying this unit, you should be able to:

- (i) State the properties of metals
- (ii) List the uses of metals
- (iii) Apply the knowledge of geometry in designing shapes
- (iv) Identify tools in metal work

### **4.2 MAIN CONTENT**

#### **4.2.1 METALS**

Metals constitute most portions of the universe. A look at the periodic table of elements reveals that about 80% of the elements discovered thus far are metals. Metals are categorized into alkali, alkaline earth, transition metals, lanthanides and actinides. Metals are substances that conduct electricity and heat. The electrical and thermal conductivity of non-transition metals is due to the presence of free electrons capable of moving while those in transition metals are due to the band theory. The band theory takes into account the interaction between the available free electrons and the d-orbital electrons.

### **SELF ASSESSMENT 1**

State any five (5) properties of metals.

There are specific properties that distinguish metals from other elements. The properties of metals are:

- 1). Metals reflect light with a shiny appearance.
- 2). Metals are good conductor of heat and electricity.
- 3). Metals are mostly malleable which means they can be hammered into thin sheets.
- 4). Metals are ductile, meaning that they can be drawn into wires.
- 5). Metals show different properties in their pure or free state and impure or combined state.
- 6). Metals are highly reactive and resistant to oxidation.

### **4.2.2 ABOUT METALS**

Our forefathers have known and used many metals discovered around them. In Nigeria for example, gold has been discovered and worked upon in places like Ijesha land and Ilorin. Silver and copper were used in making the coins of the country's money. Iron and steel found in rocks have displayed prominence in constructions. Today, as more discoveries are made, a number of other benefits are derived from metals; eg, radioactive substances now serve as fuel in nuclear reactions.

### **SELF ASSESSMENT 2**

Outline the uses of metals.

A wide range of usefulness of metals is due to their alloys. Such alloys have high stiffness and strength required for structural members in addition to being relatively easily and inexpensively fabricated. Similarly, metals have high formability. This means that metals can be deformed permanently without fracture. Iron has been utilized widely in cast iron, low-carbon steels, alloy steels, stainless steels, etc. metals generally found themselves very useful as stated below:

- Metals are used in electric power transmission lines and electrical generators and motors, eg, copper and aluminum.
- Metals are used as heat exchanger in automobile radiators and air conditioners, eg, copper and aluminum.
- Metal alloy is used in heating element in hair dryers or toasters, eg, nichrome (60% nickel, 16 % chromium, 24 % iron).
- Metals are used in thermometers and transformers, eg, mercury.
- Metals are used as filament in incandescent bulbs, eg, tungsten.
- Metals are used as catalysts in petroleum cracking and in pollution control devices in automobiles, eg, platinum, rhodium.

### **4.2.3 GEOMETRY**

Geometry is basically the study of properties of space and of figures in space from scientific point of view. It is the existence of straight lines in physical space and surface of a sphere. Geometry ordinarily does not deal with physical space or physical figures rather, it is concerned with idealizations. It is known that a physical straight line has both thickness and complicated molecular structure. The mathematical concept of the line however, ignores width and molecular structure but concentrates on the extension and straightness of the line.

### **SELF ASSESSMENT 3**

Why is deductive reasoning more effective in the study of geometry?

Deductive reasoning is necessary in the study of geometry because it usually rely on ideas already accepted as true. It involves the combination of such truths in a logical manner to reach a conclusion. As such, an original time statement guides deductive reasoning that normally leads to true conclusions. For illustration;

1. A quadrilateral can be divided into two equal triangles- ‘this is true’
2. The sum of the measures of the three angles in a triangle is  $180^\circ$  – ‘this is true’

Thus, by deductive reasoning, it may be concluded that the sum of the measure of the four angles in a quadrilateral must be equal to  $2 \times 180^\circ$  which no doubt gives  $360^\circ$ .

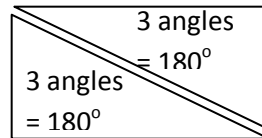
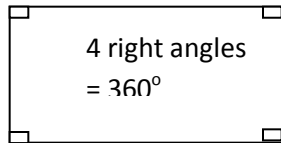

#### **SELF ASSESSMENT 4**

Why is geometry important in metal work?

Geometry is known to be paramount in the study of shape, size and position of geometrical figures, eg, cubes and spheres. Geometry is simply referred to ‘earth and to measure’ from Greek connotation. Thus, geometry was applied in measuring lengths and areas of land especially by ancient Egyptians. Geometry is quite important in metal work because metal work is all about designing shapes for a construction.

It is possible for us to better understand and appreciate our world with the knowledge of geometry, eg, house and building have always got rectangular walls; similarly, bridges have triangular supports, while naturally, the earthworm takes the shape of a cylinder and football or ping pong has the shape of circle, etc.

The properties of geometry are important for architects, carpenters and metalworkers to be able to construct stable and attractive buildings, furniture or other complicated structures like automobiles and machine parts.

#### **4.2.4 TOOLS IN METAL WORKS**

Metal works is any work carried out on metals. This is usually possible either by carving or hammering. Metalworking is an act of given metals a desired shape. A blacksmith for example can heat a bar of iron until it is soft and then hammer it o make a hoe or trap, etc. a goldsmith does similar work on gold to produce jewelries.

#### **SELF ASSESSMENT 4**

Name the tools in metal works and their uses.

The tools used for metal works include the following:

- Hacksaw: this is used in cutting sheet metals
- File: is used for smoothing of rough spots or burrs from a metal work piece.
- Chisel: is used to cut metal off or cut grooves
- Hammer: is used to hit chisel for cutting of required shape or for beating of hot iron to flat
- Shares (tin snips): is basically for cutting metals
- Vice: usually fixed tightly to a workbench is used to hold metal in position when a cutting is required
- Anvil: is a tool on which hammering of heated iron to the desired shape is done, etc.



www.shutterstock.com · 107861786

## **SELF ASSESSMENT 4**

Give the classifications of metalworking

Metalworking can be classified into four:

1. Cutting
2. Chipless cutting
3. Forming and
4. Joining.

### **4.3 CONCLUSION**

This unit has exposed you to the meaning of metal and its properties. You also learned a brief history on metals. You equally learned the meaning of geometry and its application in metal work and of course the tools needed for metal work were listed.

### **4.4 SUMMARY**

In this unit you have been taught that metals are substances that conduct electricity and heat. The unit outlined five properties of metals to distinguish them from other elements on the periodic table. The unit as well identified the earliest discoveries of metals and what they were used for. The importance of geometry in shaping was enumerated for you to appreciate its application in designs and constructions. It is no doubt that the unit has enabled you to identify tools needed in metal workshop.

### **4.5 TUTOR MARKED ASSIGNMENT**

1. Explain how metal pieces can be joined together by (a) welding (b) brazing (c) soldering and (d) riveting.

### **4.6 REFERENCES/FURTHER READINGS**

- Encyclopedia Americana International Edition (2006). Danbury, connect cut: Scholastic library publishing, Inc. (12)
- Encyclopedia Americana International Edition (2006). Danbury, connect cut: Scholastic library publishing, Inc. (18)
- The World Book Encyclopedia (2004). World Book Inc. Chicago: 233 North Madigan Avenue, 1160601 (8).
- The World Book Encyclopedia (2004). World Book Inc. Chicago: 233 North Madigan Avenue, 1160601 (13).
- The New Encyclopedia Britannia. Chicago : (8).  
www.shutterstock.com

## **UNIT 5 ELECTRICAL WORK TOOLS**

### **5.0 INTRODUCTION**

This unit introduces you to the meaning of electricity and some electrical terms. You will learn how to sketch some simple electrical instruments used in electrical workshop. The unit will expose you to electric circuit and elementary electronics.

### **5.1 OBJECTIVES**

After studying this unit, you should be able to:

- (i) Define electricity
- (ii) Sketch basic electrical materials
- (iii) Make circuit diagrams
- (iv) Identify basic electronic components and tools.

### **5.2 MAIN CONTENT**

#### **5.2.1 MEANING OF ELECTRICITY**

We have known that matter is anything that has mass and occupies space. We do also know that matter is composed of atoms and molecules which are held together by electrical force. This means electricity determines to some extent the structure of objects that ever exist. Electricity is a form of energy that operates everywhere in the universe. It operates in the atmosphere, space, living organisms, chemical bonds, etc. electricity is linked to such biological processes as the transmission of electric signals along nerves (impulse transmission) to get the brain (central nervous system) informed of necessary stimuli. In the reverse order, the brain communicates the various body parts (cells, muscles, ligaments, etc) via electrical signals for a given response to the stimuli.

Electricity and magnetism complement each other to produce a force referred to as electromagnetism. This force has been harnessed to carry out a number of operations with relatively little efforts. The importance attached to electricity prompted curiosity in determining new source of energy which have practical applications and compelling change on how mankind live. Thus, scientists have learned possible means of generating electric energy in large quantities. In Nigeria for instance, electrical energy has been generated in power plants (hydro, thermal, gas) and recently, solar integrated with wind mill. Other new sources of energy generation are in bio-fuels and nuclear or radioactive substances. Inventors have developed a number of devices that can convert the electrical energy to produce effect in necessities of life like light, heat, motion and communication (sound).

## **SELF ASSESSMENT 1**

Differentiate electric charge from electric current

It is known now that matter is composed of atoms. Any atom as it were is equally known to be made of two kinds of tiny particles known as electrons and quarks. Electron and quarks possess electric charges. The quarks are the larger particles known as protons and neutrons. Electrons as it were have the negative charge while the quarks have either negative or positive charges. It is the protons of quarks that possess the positive charge of the same size as in the electron's negative charge. This is so because each proton has two quarks with  $\frac{2}{3}$  unit of positive charge and one quark with  $\frac{1}{3}$  unit of negative charge. Neutrons however, has two quarks with  $\frac{1}{3}$  unit of negative charge each and one quark with  $\frac{2}{3}$  unit of positive charge. By simple summation, these charges no doubt cancel each other out. As a result, the neutron remains electrical neutral (ie, no electric charge). Charges can either attract or repel each other depending on whether they are unlike or alike. It is this power to attract or repel that is effected through electric fields.

Electric current can be pictured as the flow of electric charge through a conductor (metals). It is known that as current flows, energy is conveyed along in the same direction. Such energy is converted to other useful forms as it flows through electrical device. For instance, electrical energy can be converted to heat in electric pressing iron, light in light bulb, sound in electronics like radio, etc.

## **SELF ASSESSMENT 2**

Name the devices in electrical workshop

The possible devices in an electrical workplace include the following:

- (1) Cell/battery
- (2) Switch
- (3) Ammeter
- (4) Voltmeter
- (5) Galvanometer
- (6) Fuse
- (7) Resistor
- (8) Lamp
- (9) Capacitor
- (10) Rheostat, etc.



## 5.2.2 ELECTRIC CIRCUIT

We have learned in 5.2.1 above that as electric current flows, it carries energy along. If the electric energy must be of any use in electric device, it must be connected to a source. As such, it is necessary that a complete path is provided for electric current to flow, originating from the source and flows through the device and return to the source. This complete path of flow of electric current is known as electric circuit.

### SELF ASSESSMENT 3

Identify and describe types of circuit

Two laws have been connected to the performance of electric circuits namely: Ohm's and Kirchhoffs circuit rules. There are four different circuits identified here as:

- 1). Direct current circuit: this carries current which flows in only one direction.
- 2). Alternating current circuit: this conveys current that beats in a back forth manner several times each second. This phenomenon is exhibited in most household circuits.
- 3). Series circuit: this is the path along which a whole current flows through each component of the circuit.

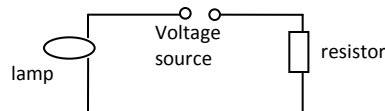

- 4). Parallel circuit: this is made up of branches in order that current is divided into parts as it flows through the branches of the component of the current.

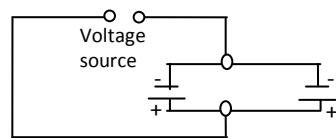

## 5.2.3 COMPONENTS OF ELECTRONIC DEVICE

Electronics is a scientific study that deals with the theory, design and application of electronic devices. It is specifically a branch of physics and engineering that specializes in controlling the flow of electric charges in devices for required purpose. This practice results in the composition of such devices as radio, television, radar, computer, GSM, ATM, etc. a device like the electron tube for instance requires the flow of electrons in a vacuum or gas while a transistor requires a flow of electrons in a semiconductor, eg, germanium or silicon.

Electronics as part of field of electricity operates on two basic elements namely electric current and electric voltage. In self assessment 1 above, you have learned about, electric current

as the flow of electric charges. Electric voltage however, is a force or pressure that pushes the charges to move in the same direction. This confirms why electronics deals with the use of current and voltage to carry electric signal such as sound, pictures, letters, etc.

#### **SELF ASSESSMENT 4**

Name the possible components of electronic device.

The possible components of electronic device are:

- (i) Diode: this blocks current from flowing through it in one direction but allows current to pass in the other.
- (ii) Switch: this directs the path of a current by turning a circuit on or off.
- (iii) Transistor: uses a small signal to control a strong current. It is an arrangement of p-n junctions used to amplify a signal or switch a current on or off.
- (iv) Vacuum tube: this controls a signal in a container from which most of the air has been evacuated.
- (v) Resistor: this decreases the flow of current
- (vi) Rectifier: this changes alternating current to direct current.
- (vii) Microprocessor: its an integrated current that controls circuit on one chip due to its memory and processing capacity.

#### **SELF ASSESSMENT 5**

Describe briefly how electronic system works

Operation of electronic device/system is divided into three stages such as:

- (i) Input stage: in which information enters as signals into the system.
- (ii) Processing stage: at which signals are manipulated.
- (iii) Output stage: in which the processed signals are changed into forms understandable by users.

First, the device should have a small key pad like in a simple calculator with keys for numbers and operations. The device should as well possess a display screen to show results. This device is powered by a small battery or panel of solar cells. Tiny circuits are beneath the keypad that operates the calculator. When a key is pressed, it creates a pulse of electric charge that indicates a signal number or operation. This signal travels through wires to the circuit. A division of labour is exhibited by each circuit, so, some store signals temporarily to await further instruction while others change signals instantly according to instruction. Circuits then send signals that either light up or darken certain areas on display screen in order that the result is displayed.

#### **5.2.4 BASIC TOOLS IN ELECTRICAL/ELECTRONIC WORKSHOP**

Possible tools required to carry out works in an electrical/electronic workshop may be any of the following: pliers, screwdriver, testing meter, knife, glove, etc

### **5.3 CONCLUSION**

This unit has given the meaning of electricity and explained the term electric charge and electric current. The devices in electrical workshop were listed. You also learned the categories of electric circuit and the components of electronic device.

### **5.4 SUMMARY**

In this unit, you have learned that electricity is a form of energy that abound and is put to use in nature. The linkage of electricity to living organisms body mechanism as in impulse transmission and physical phenomenon like electromagnetism was discussed. You as well discovered that electric charge and electric current are two elements of electricity. You als understand the usage of electric current and electric voltage as electrical language. This unit has exposed you to classes of circuits as direct current, alternating current, series and parallel. The components of electronic device were not left out as well as the basic tools needed in electrical/electronic workshop.

### **5.5 TUTOR MARKED ASSIGNMENT**

Sketch the electrical symbols of the following electrical materials: switch, battery, lamp, galvanometer, ammeter, voltmeter, resistor, closed circuit and open circuit.

### **5.6 REFERENCES/FURTHER READINGS.**

Chamber English Dictionary (1992). Toronto

Encyclopedia Americana International Edition (2006). Danbury, connect cut: Scholastic library publishing, Inc. (10)

The New Encyclopedia Britannia. Chicago : (4).

The World Book Encyclopedia (2004). World Book Inc. Chicago: 233 North Madigan Avenue, 1160601 (6).

## **MODULE 2 SKILLS ACQUISITION**

### **INTRODUCTION**

It is evident that in the new millennium, young people in the present global village possess ideas, talents, skills and knowledge that promote entrepreneurship. This is a new wave of making the most of human ecology. With this, a new perspective of venturing into economic creativity tends to shift from old and more established businesses to small scale but sustainable fragments. We do also realize that the face of the world economy has over the years shifted and as such the young generations of these days have indicated interest in entrepreneurial activities.

The concern of this module therefore is to examine among other things the concept of entrepreneurship, skill development, models of skill acquisition as well as the importance of skill acquisition. In view of this, the course material for this module two is divided into four (4) units as follows:

Unit 1: Entrepreneurship

Unit 2: Skill development

Unit 3: Skill acquisition models

Unit 4: Importance of skill acquisition

### **UNIT 1: ENTREPRENEURSHIP CONTENTS**

#### **1.0 INTRODUCTION**

In this unit, you will learn the meaning of entrepreneur and entrepreneurship. You will as well be exposed to the forces propelling the youth of today to venture in entrepreneurial activity.

#### **1.1 OBJECTIVES**

After studying this unit you should be able to :

- i. Define entrepreneur and explain the concepts of entrepreneur
- ii. State the characteristics of an entrepreneur
- iii. Identify the components of entrepreneurial role behavior.
- iv. Outline the contributions of small scale business to national development.

#### **1.2 MAIN CONTENT**

##### **1.2.1 Meaning of entrepreneur**

In our traditional setting, production was carried out usually in small workshops or sheds within residential premises. The tools needed for the venture are possessed by the workers. The workers also supplied a bit of capital required to plan for the enterprise. In short, the worker was all-in-all: the landlord, the financier the organizer and the worker at the same time. Fortunately, enough, technological improvements, injected conditions of production and marketing that indicate the need for spontaneous change. Due to this innovation, the process of production has transmitted from simple to complex. This days, factors of production are may be coordinated by individuals or group of individual, at different locations within country or continent. This calls for an effort

in bringing all the factors of production such coordination supervision and management together. An individual or group of individuals who oversee the relationship of the factors of production is an entrepreneur.

## **SELF ASSESSMENT 1**

### **Who is an entrepreneur?**

The word entrepreneur is coined from French origin which translates into enterpriser. For a day to day operation of any business enterprise become viable, would have concurred an idea about the business, design the organization of the form acquire capital, employ labour, make necessary links with suppliers, consumers and government as well as translate the conception into functioning organization. These efforts of an entrepreneur bring about innovations in an economy. We can rightly say here that an entrepreneur is the prime initiator of all economic activity in a mixed economic system. Bell and Worthington (1983) referred to an entrepreneur as an individual or group of individuals who are responsible for self directed initiatives and personal risk in creating and operating a profit-oriented business. An entrepreneur is viewed to be a person or group of persons who provides capital, takes risks, make decision and reaps the profit or losses of the business. It is an individual who takes the initiative of starting and running small or large enterprise and ensure that it works.

## **SELF ASSESSMENT 2**

In what capacity does an entrepreneur act?

An entrepreneur can act in following capacities

- As a boss who decides the pattern of running the business
- Decisions as to what to be produced where and how it should be produced and the disposition of the consumers.
- Organization of work of different factors of production
- Attempt to anticipate future demand and supply costs.
- As innovators of new ideas commodities process, machinery etc.
- Purchasing raw materials and marketing finished products.

## **SELF ASSESSMENT 3**

What are the characteristics of an entrepreneur?

The following constitutes the characteristics of an entrepreneur

- He shows concern for greater achievement
- He exercises capability of taken charge of the operations

- He does not allow any uncertainty to deter his move
- He is known for risk taking.

### **1.2.2 CONCEPT OF ENTREPRENEURSHIP**

Entrepreneurship as a term can first be addressed by examining its characteristics which include:

- Creating and innovation
- Resource gathering and funding of economic organization and
- Chance for gain under risk and uncertainty

Harmonizing these traits, entrepreneurship can therefore mean the creation of an innovative economic organization for the purpose of growth under conditions of risk and uncertainty. The concept of entrepreneurship is popular with economic theory. Bygrave and Hoyer (1991) in Okhawere (2005) considered entrepreneurial process involves all the functions, activities and actions associated with the perception of opportunities and the creation of organizations to pursue them. Other school of thought views the concept from its historical perspective/account of the development and uses. Long (1983) for instance traced the root of the word entrepreneurship as far as 800 years to the French verb “entreprendre” which mean to do something. In like manner Schumpeter had emphasized that “without innovations, there cannot be entrepreneurs; without entrepreneurial achievement, there cannot be capitalist returns and no capitalist propulsion (McGraw, 1991) Long (1983) has also expressed three traits in varying degrees that have been implicated on entrepreneurship from historical perspective.

The three traits include: uncertainty and risk”, complementary managerial competence” and create opportunism. Furthermore, Reich (1987) suggested that classical theories of entrepreneurship can be applied to the current practices through the concept of entrepreneurial team. He compares the traditional view of entrepreneurship with a team-oriented approach in which a group of individuals bring their individual talents to bear on a problem. Reich asserted that for us to compete effectively in today’s world, we must begin to celebrate collectively entrepreneurship, endeavours in which the whole of the effort is greater than the sum of individual contributions.

### **SELF ASSESSMENT 4**

What are the components of entrepreneurial role behavior?

The components of entrepreneurial role behavior include the following list.

- knowledge of the results of actions
- organizational skills
- anticipation of future possibilities

- individual responsibilities
- energetic
- moderate in risk taking

## **SELF ASSESSMENT 5**

What are the contributions of small business firms to development process in Nigeria?

The contributions of small business firm to the development process in Nigeria can be viewed from the social and economic benefits. Small business firms contribute social benefits in the areas of

- transformation of traditional/indigenous industries
- stimulation of indigenous entrepreneurship and technology
- creation of jobs and
- redistribution of wealth and income

The economic benefits derivable from small business firms are linked to

- the utilization of local resources
- disposal and diversification of economic activities and
- mobilization of savings.

## **1.3 CONCLUSION**

You have learnt from the unit the meaning of entrepreneur and entrepreneurship. The unit identified the characteristics of entrepreneur and components of entrepreneurial role behavior and the contributions of small business firms.

## **1.4 SUMMARY**

In this unit you learned that entrepreneur is an individual or group of individual who accept responsibilities for self directed initiatives and personal risk in creating and operating a profit oriented business. The unit also revealed that entrepreneurship as a concept can better be understood from the perspective of history, classical theories etc. The unit also has the characteristics of an entrepreneur, the components of entrepreneurial role behavior and the contributions of small business firm toward the development of Nigeria as a nation.

## **1.5 TUTOR MARKED ASSIGNMENT**

Enumerate the social contributions of small business firms to the development of Nigeria

## **1.6 REFERENCES/FURTHER READINGS**

- Alaba, A (2005) New Era entrepreneurship. Lagos: Soma Associates
- Bell, T. H. & Worthington, R. M. (1983). United State Department of Education Policy Statement in Entrepreneurship Education.
- Dollinger, M.J (2006) Entrepreneurship strategies and resources third Edition. Delhi India: Dorling Kindersley
- Long, W. (1983). The meaning of entrepreneurship. American journal of small Business 8(2) 47-59.
- Okhawere, P. Y. O. (2005). Entrepreneurship: Theory and practice. Kontagora: Unique priting press.
- Owualah, S.I (2005). Entrepreneurship in small Business firms Ikeja Lagos: G- MAG investments Ltd.
- Reich, R.B (1987). Entrepreneurship reconsidered. The team as hero Harvard Business Review.



## **UNIT 2 SKILLS DEVELOPMENT**

### **2.0 INTRODUCTION**

This unit will lead you through the understanding of the meaning of skill. It will also direct you to identifying some basic skills in teaching. You will also learn from the unit the meaning of skill acquisition and how to develop skills.

### **2.1 OBJECTIVES**

After you have participated in learning this unit, you should be able to:

- i. define skill acquisition
- ii. gives reasons for skill acquisition
- iii. differentiate skill types

### **2.2 MAIN CONTENT**

#### **2.2.1 Meaning of Skill Acquisition**

The Chambers English Dictionary defines skill as aptitudes and competencies appropriate for a particular job. Skill is the ability to get something done adequately. This kind of ability is obtained through training, learning and experiences usually by means of apprenticeship. Skill acquisition is thus the proficiency gained after the exposure of an individual to and going through a specific training. Any skill developed usually depends upon the area the individual is exposed to. For instance, a motor skill as learned to instill the ability to perform or coordinate set of physical movement e.g hand writing , typing, playing musical instrument, sporting activities.

#### **SELF ASSESSMENT 1**

What is apprenticeship?

The Encarta Dictionaries defines an apprentice as a trainee or an inexperienced person. An apprentice is someone being trained by a skilled professional in art, craft or trade. Apprenticeship is a system of learning the skills of a craft or trade or art from experts in the field by participating in the work they do for a set period of duration. In Nigeria hitherto, there are a number of skills that are acquired by younger generations from older professionals e.g auto-mechanic, furniture work, or carpentry, bricklaying etc.

#### **SELF ASSESSMENT 2**

What are the human body components needed for skills acquisition?

Skills acquisition involves learning to gain knowledge or develop the ability to perform new tasks or show new behavior. In learning, all human senses are put to use and they are all coordinated by the brain. Before the children are enrolled in school for instance, they learn to walk, talk, use their hands to manipulate toys, bring food to their mouth and brush their teeth or comb their hair etc. in the same manner, all the senses are used to interact and learn about their parents, siblings, friends and the entire physical environment. When children enter school, they learn basic academic subjects through reading, writing drawing, calculating etc. their learning is not limited to the classroom. The behaviours so learned are likely to be rewarded or punished. This enables them to acquire social skills for interacting with other colleague. Outside school environment, people learn to adapt to many changes that are likely to affect their lives and those of others like having life partners, raising children, finding a secured job etc.

### **2.2.2 REASONS FOR SKILLS ACQUISITION**

Each time a person adequately recall a prior experience; it is assumed that the individual has a good memory. Memory is critical to human beings as well as to other living organisms. Practically, the learned and stored information in our memory is a function of our daily activities talking, understanding, reading, socializing etc. within our environment.

### **SELF ASSESSMENT 3**

What is the relationship between memory and skills acquisition?

Memory allows man to retrieve an experience from the distant past or moments ago. Memory forms habit in such a manner that as we interact with the environment, we acquire the skills to comprehend language, recognize our friends and family members etc. without the skills to access past experience, we would be unable to comprehend language, recognize our friends and have meaningful interaction with the environment therefore making life a sense of disconnected experiences. With skill acquisition, it is possible for learners to perceive variables and parameters and take appropriate decisions having critically considered the objectives of any situation.

### **2.2.3 TYPES O SKILLS**

There exists a diverse of skills which could be categorized into hard, soft or life skills. Learning is acquiring new knowledge, behaviors, skill, values or preferences and may involve synthesizing different types of information. Acquiring skills at procedural tasks is of great importance for early learners as well as for experience personnel's who need practice at new procedures as they are introduced or with existing tasks and procedures that are not performed frequently. One's skills at tasks and procedures can be enhances when the performance on them can be measured using various "metrics" such as time on task, error rate or coordination. Such metrics may eventually allow the formative assessment of learners as they progress in skill and

the establishment of benchmarks of achievement for both inexperienced and experienced personnel's alike. When a learner works in an artificial environment it allows him/her to make mistakes without the need for expert intervention. Thus, such learner gains a powerful learning experience not available in the real world by seeing the outcome of his/her mistakes.

#### **SELF ASSESSMENT 4**

What are the skills necessary for teachers to be on the verge of innovations?

Teachers would be of social point if he/she is equipped with organizational active participation, questioning, progress monitoring, service work, communication, resource management, time scheduling, brain were skills as well as skills in using variety of strategies and skills in using Aids. The teacher should make sure that the learners are the focus. Being learner-centered means focusing on what the students want to understand and involving them in the learning as much as possible (Fadul, 2006). Students can be directed to carry out some tasks based on learning objectives. It is a good idea to note down who is responsible for a task and requiring such learner to present it at the start of a session (Craig, 2009).

#### **SELF ASSESSMENT 5**

Explain briefly the skills classified as hard, soft and life

Hard skills are traditional skills which are unique, but teachable and are required to be successful at a given word/job. They can easily be observed and quantified probably through a scientific assessment. Examples include operating a machine, calculate, typing, driving a car.

Soft skills are the wide variety of business skills that fall into three different categories namely (1) interaction teamwork or collaboration and demonstrating empathy. (2) professional and or work ethic, eg work setting, integrity, motivation etc (3) critical thinking or problem solving.

Life skills are the abilities for adaptive and positive behavior that enable individuals deal effectively with the demands and challenges of everyday life, eg psychological skills that determine value behavior such as reflective (self awareness) and inter-personal (self-esteem, tolerance, competencies etc).

Life skills- based Education are involved in giving support to a child's development and health promotion. This made the 1989 convention on Right of child (CRC) linked life skills to education and stated that education should be directed towards the development of the child's fullest. This has called for the inclusion of life skills-based education among essential learning tools for survival, capacity development and quality life. It is the education that includes learning to know, to do, to live together and to be. It is recognized as a methodology for addressing development and thematic responses and the expected outcomes are enormous. For example:

combination of knowledge, values, attitudes and skills that hinge on critical thinking and problem solving as well as self management and communication etc.

### **2.3 CONCLUSION**

This unit has you to understand the meaning of skill acquisition and reasons for acquiring skills. You also learned from the unit a variety of skills applicable in learning a task.

### **2.4 SUMMARY**

In this unit you learned that skill is the ability to do something in the most appropriate manner similarly, you learned that skill acquisition is the proficiency gained after an individual has been exposed to and going through a given training. Apprenticeship is known in this unit as the system of learning a skill of an art, a craft or trade from experts in a field by taking part in a job over a period of time. Skill acquisition is said to involve learning to gain knowledge to perform new tasks. Reasons for acquiring skills were given to embrace our daily interactions with the environment. Finally, the unit elaborated on the diverse kinds of skills in learning and at work to range from hard, soft and life.

### **2.5 TUTOR MARKED ASSIGNMENT**

How can the skills possessed by a learner on a task and procedure be enhanced?

### **2.6 REFERENCES/FURTHER READINGS**

Chambers English Dictionary (1992) W&R Chambers ltd NY

Craig, R. (2009) learning skills (retrieved from <http://www.asuz.org/asa/education/learn/study-skills.htm> on 8/12/14.

Encarta Dictionary (DVD 2009) premium

Fadual, J. (2006) Mathematical formulations of learning based on ten learning principles. International journal of learning 13 (6).139-152

Methods of teacher training 14 New Delhi; APH publishing corporation.

Mishra, R.C, Sharma, p.& Bansal, H. (2012)international encyclopedia of education. Modern

## **UNIT 3 SKILLS ACQUISITION MODELS**

### **3.0 INTRODUCTION**

This unit will expose you to the meaning of models and specific models of skills acquisition in the field of education. The importance of skills acquisition in life will also be discussed

### **3.1 OBJECTIVES**

After your interaction with the content of this unit, you should be able to:

- i. Define a model
- ii. Describe a skill acquisition model
- iii. Compose the importance of skills acquisition

### **3.2 MAIN CONTENT**

#### **3.2.1 MEANING OF A MODEL**

A model is a simplified version of something complex used in analyzing and solving problems or making prediction (Encarta Dictionaries). For a car to be built for instance, a research must be carried out about it. It must also be designed, and developed into workable product. Components of the whole car system are fully developed into a prototype to incorporate into a model. As technology advances new models continually feature new systems and innovations. The idea about a model has been portrayed in Shakespeare as quoted.

“when we mean to build , we first survey the plot, then draw the model; and when we see the figure of the house, then we must rate the cost of erection, which if we find out weights ability, what do we then but draw a new the model in fewer offices or at last desist to build at all?”.

### **SELF ASSESSMENT 1**

What is the relationship of a model to learning according to Piaget’s theory of developmental stages?

When a child recognizes any cognitive conflict, the recognition motivates him/her to attempt to resolve the conflict. This means of resolving a conflict by the child is known as “equilibration”. Piaget maintains that equilibration is nothing but self-regulation that upholds a balance between “assimilation” and “accommodation” cognitive conflict has high arousal potential as it can motivate learners to attempt to resolve differences by seeking new information or by trying to recognize the knowledge the learners already have. Keller (1987) argues that

attention as one of the elements of motivation is organized when students experience cognitive conflict. He thus developed an Attention, Relevance, Confidence and Satisfaction (ARCS) Model that links the relationship between cognitive conflict and motivation. It is imperative as a result that for a teacher to arouse students motivation to engage in a task, he/she needs to use methods that draw on existing interests or presents students with baffling demonstration or arguments.

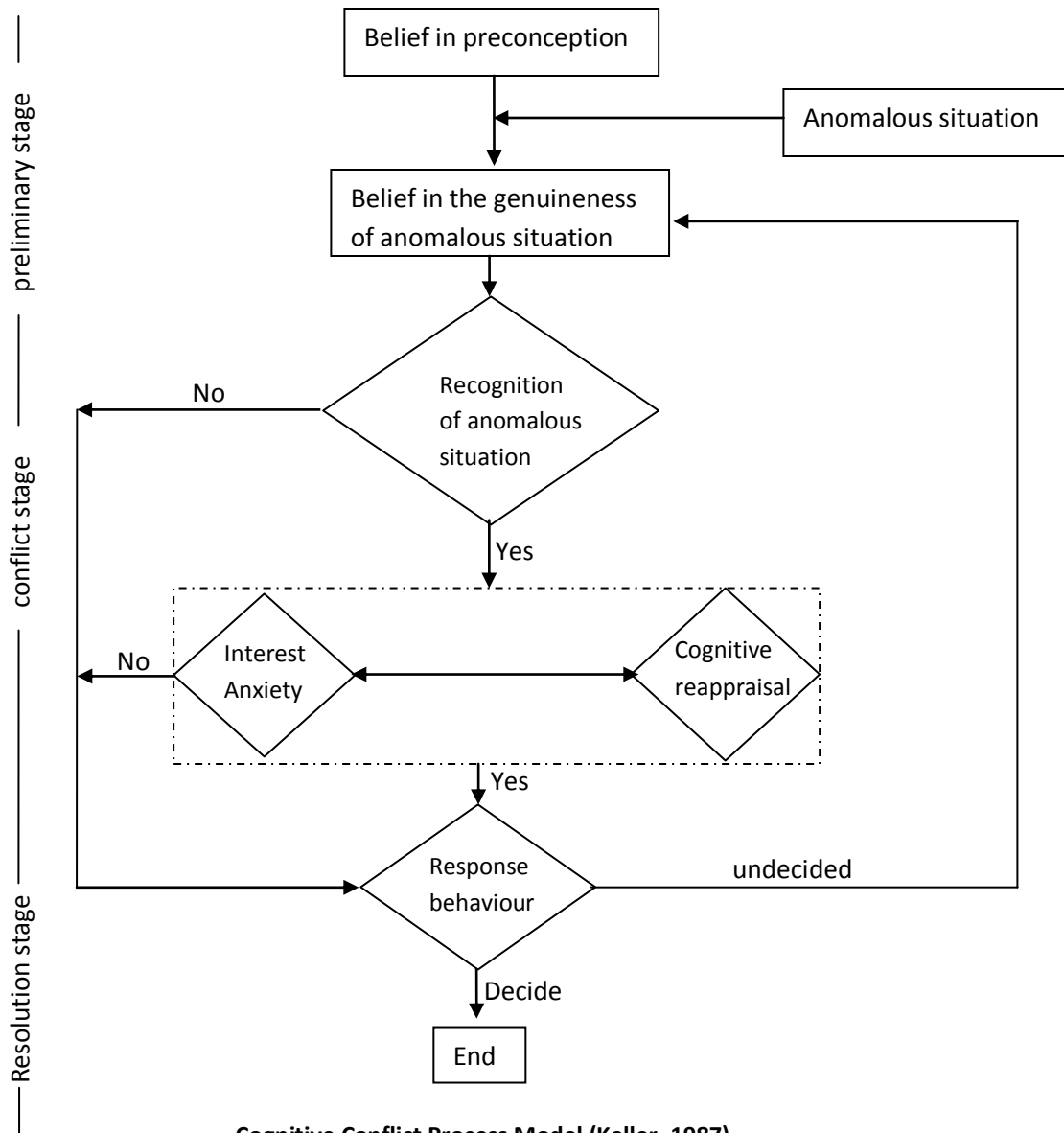

**Cognitive Conflict Process Model (Keller, 1987)**

### 3.2.2 MODEL OF SKILLS ACQUISITION

Relevant to the fields of education and operations research the Dreyfus model of skill acquisition is a model of how learners acquire skills through formal instruction and practicing.

This model was proposed in 1980 by Star and Dreyfus. The distinct stages are: novice, advanced beginner, competent, proficient and expert.

## **SELF ASSESSMENT 2**

Outline the tenet of the stages of Dreyfus model of skill acquisition.

- (1) The novice stage of stage of the Dreyfus model of skill acquisition requires that a person follows rules to letter, without context, with no sense of responsibility beyond following the rules exactly.
- (2) Advanced beginner-shows limited situational perception. The individual participates in activities of which all aspects of the work treated separately with equal importance.
- (3) The competence stage is reached when the person develops organizing principles to quickly access the particular rules that are most relevant to the specific task at hand. Competence is characterized by active decision making in selecting a course of action.
- (4) Proficiency in one's skills is shown by an individual who develop intention to guide his/her decisions and devise their own rules to formulate plans. The progression is therefore from rigid adherence to rules to an intuitive mode of reasoning based on implicit but not expressed knowledge.
- (5) An expert as the stage of skill acquisition transcends relevance on rules, guidelines and maxims. The individual is filled with instinctive grasps of situations based on deep, tacit understanding. Such person has vision of what is possible and uses analytical approaches in any new situation or in any case of problems.

## **3.3 CONCLUSION**

You have learned from this unit the meaning of a model, the relationship of a model to learning. The unit also discussed a model of skill acquisition.

## **3.4 SUMMARY**

This unit defines a model as a simplified version of something complex used in analyzing and solving problems. Similarly, the relationship of a model to learning was discussed with regards to the views of Piaget and Keller emphasizing attempt to resolve cognitive conflict. The unit also explained the proposition of Dreyfus model of skill acquisition as a model showing how learners acquire skills through formal instruction and practicing. The stages of Dreyfus model of skill acquisition were identified as novice, advanced beginners, competent, proficient and expert.

## **3.5 TUTOR MARKED ASSESSMENT**

Compare the novice and expert postulates of Dreyfus model of skill acquisition.

### **3.6 REFERENCES/FURTHER READINGS**

Encarta Dictionaries (DVD 2009) premium

Keller, J.M (1984) The use of the ARCS model of motivation in teacher training. In K. Shaud A. J Trott (Eds) aspects of education technology 17. Staff development and career updating. London : Kogan page

Piaget J. (1985) The equilibration of Cognitive structure: the central problem of intellectual development. Chicago, IL: University of Chicago press.



## **UNIT 4 IMPORTANCE OF SKILLS ACQUISITION**

### **4.0 INTRODUCTION**

This unit is prepared to lead to discover the importance of skills acquisition in life of human organisms. The unit will similarly discuss the roles of skills acquisition and the benefits inherent thereof.

#### **4.1 OBJECTIVE**

Having study this unit, you should be able to:

- i. state the roles of skills acquisition learners
- ii. outline the benefits derivable in skills acquisition

#### **4.2 MAIN CONTENT**

##### **4.2.1 ROLES OF SKILLS ACQUISITION**

Skills acquisition is important because the learners mind and strength are made to function complementarily. The learner is expected to improve on his/her hands-on capability and or the expert trainer influences the achievement of the objectives of psychomotor domain of learning.

#### **SELF ASSESSMENT 1**

State the roles of skills acquisition

The roles of skills acquisition are enormous. These are stated as follows:

1. Skills acquisition helps to build up the competence level of the workers.
2. It also helps workers/learners to improve networking within and outside the organization.
3. Skills acquisition encourages the workers to demonstrate empathy, that is, understanding of another's feeling. This is the ability to identify with and understanding others person's feelings or difficulties.
4. Skills acquisition helps to build strong relationships or all alliance between or among co-workers in an organization.
5. Skills acquisition brings about creativity and innovations in the works people do.
6. It enables the fabrication of prototypes as well as finished products for national development.

#### **4.2.2 BENEFITS OF SKILLS ACQUISITION**

An individual who has acquired a skill stands to derive something that has a good effect or promote well being. In other words, it is the advantage inherent in what an individual takes pride at doing.

#### **SELF ASSESSMENT 2**

What are the benefits of skills acquisition to the learners?

When an individual venture into developing a skill and persevere to complete the procedural requirements, one stands the chances to make himself/herself feel at home and confident of survive within the competitive milieu of the society. The benefits of skills acquisition therefore may include but not limited to the following:

1. Makes workers/learners successful at work
2. It allows workers/learners to interact with one and another meaningfully.
3. Effective sharing of information with others members of the organizations is made possible
4. The spirit of team work in division of labour is improved
5. People put the goals of the organization ahead of personal goals.
6. It results in professional centrist, i.e possessing moderate views or the holding or advocating of moderate expertise views.
7. The possibility of solving identifiable problems is made easy
8. The learners/ workers acquire teamwork collaboration proficiency and achievement of both personal goals as well as those of the work place.

#### **4.2.3. BASIC SKILLS OF TEACHING**

Some aspects of teaching are best learned during induction period on the job induction programmes are known to give concentrated attention to basic skills of teaching on:

1. Daily and long-term planning of a lesson's content, teaching strategies and logistics
2. Assessing students work, including creation and scoring of teacher- made tests
3. Writing uninformative reports to parents about their children's progress and
4. Communicating more generally with parents.

#### **SELF ASSESSMENT 3**

Outline the strategies for supporting new teachers to build basic teaching skills.

The expert or experience teacher should make effort to apply one-on-one mentoring to help enhance the efficiency and competence of the new colleague. By means of organizing

facilitated peer supports, using more varieties of teaching observation, providing science laboratory technicians etc.

1. Facilitated peer support enables teacher, to get benefits from speaking with each other. Teacher would discover that it is absolutely crucial to learn that it is not just me". They in short feel overwhelmed and inadequate learning that almost every new teacher shares this experience helps them realized that their teaching difficulties are not necessarily an inducement of their abilities or preparation. Interaction with colleagues deal in depth with the basic professional skills, such as how to communicate with parent.
2. Variety of teaching observation typically experience teachers may observe new teachers. Similarly new teachers could observe the categories of others colleagues such as other new teachers, mentors, teachers in the same subject or grade and teachers of other subjects or grades.
3. Science laboratory technicians are trained and skilled in most cases on how to prepare solutions and maintenance of equipment or repair of apparatus and order suppliers etc This feature of the education system is not part of the induction programme. The new teacher stands to benefit with the presence of the technician on order to observe, acquire skills to teach hand-on science virtually everyday.
4. Smaller induction activities can be carried out by creating a required reading list, getting new teacher involved in their subjects professional association, sending teachers to professional conferences along with experienced ones. Further, such activities could involve new teachers in writing handbooks, or gaining more information in using internet facilities, conducting action – research on their own development and providing access to confidential counseling.

#### **4.3 CONCLUSION.**

This unit has discussed the importance of skills acquisition with particular emphasis on the roles and benefits. The unit as well dealt with basic skills in teaching by new teaching.

#### **4.4 SUMMARY**

This unit gave among others the roles of skills acquisition to include helping to build up competence in learners, improving networking within and outside an organization etc. the benefits of skills acquisition were also outlined to include among others made the individual to be successful at work, allows learners to interact with others meaningfully etc. The unit also itemizes the basic skills in teaching as daily and long-term planning of lesson's content, assessing students work etc finally, the unit exposes you to the strategies that work in supporting new teacher to build basic teaching skills satisfactorily.

#### **4.5 TUTOR MARKED ASSESSMENT**

Justify why variety of observations could be beneficial in building vital teaching skills.

#### **4.6 REFERENCES/FURTHER READINGS**

Encarta Dictionaries (DVD 2009) premium.

Mishra, R.C. Sharma, P. & Bansal, H. (2012) International Eyclopeadia of Education. Modern method of teacher training (14). New Delhi: APH publishing cooperation.

## **MODULE 3 APPLICATION OF TOOLS**

### **INTRODUCTION**

Trading in a workshop provides a comprehensive set of tools to help an individual or a team to achieve reasonable advances in process improvement. Most tools used nowadays are not new however but have been put together in a well-stocked toolbox. Tools are to be used in particular situations. If the tools are used for wrong application, then the required objective may definitely not be achieved successfully. Most often, we have all been guilty one way or the other of using inappropriate tools for a job; for instance the use of screw driver in place of chisel. This module ventures into the appropriate use of tools in integrated science workshop. The module basically focused on the application of a number of tools in the workshop.

The concern of this module therefore is to examine among other things the construction of wooden and glass apparatus, Art work, metal works, simple electronic circuits and safety in workshops. In view of this, the course material for this module three is divided into five (5) units as follows:

Unit 1: Wooden and glass apparatus,

Unit 2: Art work

Unit 3: Metal works

Unit 4: Simple electronic circuits

Unit 5: Safety in workshops

## **UNIT 1: WOODEN AND GLASS APPARATUS**

### **1.0 INTRODUCTION**

1.1 Objectives

1.2 Main content

1.2.1 Measurement

1.2.2 Wood Chemistry

1.2.3 Procedure for constructing wooden apparatus

1.2.4 Glass

1.2.5 Procedure for constructing glass apparatus

1.3 Conclusion

1.4 Summary

1.5 Tutor marked assessment

1.6 References/further reading

### **1.0 Introduction**

This unit will lead you through the construction of some apparatus in Integrated Science workshop such as wooden and glass. This will enable you to acquire and develop reliable skills in handling tools and fabrication of objects for instructional purposes.

## **1.1 Objectives**

After your interaction with the materials in this unit, you should be able to:

1. Make accurate measurement
2. Construct wooden apparatus
3. Produce glass apparatus

## **1.2 Main content**

### **1.2.1 Measurement**

Measurement is a concept that plays a crucial function in all aspects of science. Measurement is associated with quantities, unit and dimensions. It is the extent of determining the precision of the size, length, quantity or rate of a physical substance. For adequate measurement to be carried out, the tools used to measure any process should be up to the job. This calls for the application of Gauge repeatability and reproducibility study (Gauge R&R). It is assured that, it works well for variable measurements but may be difficult when subjective measurements are considered. One part representing system is considered acceptable.

### **Self Assessment 1**

Why would you require a data collection plan in measurement?

It is no doubt that one major requirement of measurement is to collect data. If data are to be collected, it then demands a data collection plan is produced. This will spell out what is to be collected, by whom and when. It is obvious that in the course of the collection of data, reasons for variation might be spotted or further useful measurement may be required.

### **Self Assessment 2**

Why do we need data in measurement?

The data gathered during measurement provides useful information about either common cause or special cause variation. The tool for each are different statistical process control (SPC) can be used to identify whether the process is exhibiting special cause or common cause variation. If special cause variation is present it must first be removed before dealing with common cause variation. For common cause variation, simple tools such as histogram, check sheet, scatter diagram and cause and effect diagram along with SPC can be very useful in guiding towards an understanding of the process recognition and removal of what is referred to as the eight deadly waste (transportation, inventory, motion, waiting, over production, over processing, correction and not utilizing human resources).

### **Self Assessment 3**

How can tools bring about improvement among workers?

Few tools can point out the obvious way forward which of course must rely on the knowledge and creativity of the workers. Mistake proofing provides a reliable means of avoiding human error in any future processes. This is adopted best by observing what others have done and learning from their creativity. Design of experiment is a crucial tool in this respect in order to identify which factors have a key influence on the process and how best to optimize them.

Similarly, Failure Mode and Effects Analysis (FMEA) or Risk Analysis is a tool used to identify possible risks which may lead to further improvement. It is also necessary that the process is controlled. If there is no control in the improvement envisaged, then all the work becomes in vain. Introducing a control provides the opportunity to transfer a given knowledge to similar areas thereby enabling the flow of benefits wider than simply the original project.

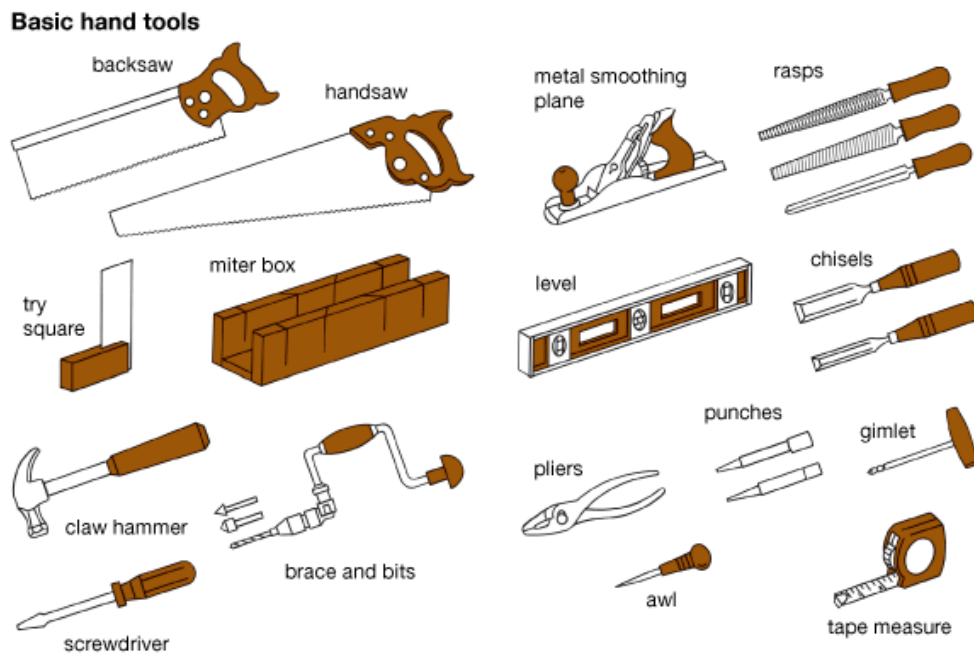

© 2010 Encyclopædia Britannica, Inc.

### 1.2.2 Wood Chemistry

Wood is a hard, fibrous substance between the pith and bark of trees. It is defined as the lignified, water conducting, strengthening and storage tissues of branches, stems, and roots of trees. Wood has been used as source of heat as material for shelter and construction wood is worked easily with tools and lends itself to manufacture and fabrication into different shapes, sizes and designs.

Wood consists of a skeleton of cellulose and varying amounts of lignin tannin, resins, gums and other materials. Cellulose is readily converted into sugars. Lignin is widely distributed of the organic substances as it cements together the wood cells and reinforces the cellulose within the cells. Lignin would need to be removed in pulping processes for white paper, rayon, cellophane etc to be successfully manufactured.

## Wood Alcohol

Robert Boyle in his *Sceptical Chymist* (1661) described the method of producing wood alcohol (poisonous). It involves the application of air evacuated container connected to a delivery tube. Pieces of dry wood are loaded into the container and heat is supplied through a burner. The wood heated in the absence of air above 30<sup>0</sup>C is termed the destructive distillation of hardwoods. Charcoal and a gas which condenses to pyrolygneous acid are produced. The acid separates into

1. a dark-coloured, heavy oil and
2. a lighter a aqueous layer of which wood alcohol, acetic acid, acetone etc are obtained.

Wood alcohol is the raw material for the manufacture of formaldehyde. It is used as antifreeze mixtures, found usefulness as a component in special fuels; it is a general solvent for paint removal, surface coating, dyes and adhesives

### 1.2.3 Procedure for Constructing Wooden Apparatus

Having all the necessary tools ready in a workshop, the steps required in constructing any wooden apparatus following the knowledge of measurement, design, sketching cutting joining and finishing. A wood would be required which is first measured with a tape or ruler to the dimension of the desired apparatus. A saw is then used to cut the marked parts of the work into pieces are after wards glued or nailed together. The testtube rack can be constructed this way and it can be finished by sand papering and polished.

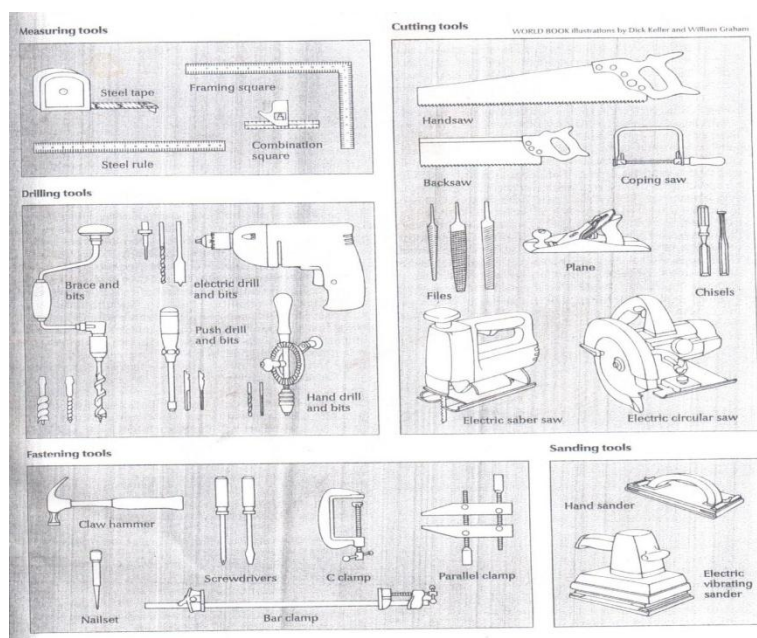

### Self Assessment 4

Give a plan on how you will construct a testtube holder and lens holder



- Obtain a sizeable soft wood and measure out specific length.
- Sketch the shape of the holder
- Cut into sizes
- Glue the pieces to form the desired holder.

### **Wood carving**

Wood can be shaped into complex forms by skillful effort of human hand using an edged steel tool. The end of a small, flat bar is ground to an angle of about 60° and then honed on a hard, fine-grained stone to a degree of sharpen that is microscopic. Shaving's of wood is removed by pushing the edge of the tool called a chisel against the block at the same time sliding it laterally. Other tools like gouge, veneers, files and rasps are used also. The files rasps are used for smoothing the surface of the wood before final sanding. Painting with opaque substances (colour) may be necessary with soft brushes that mobilize a prime coat to achieve smoothness.

### **Wood engraving**

Design is cut on a plank of desired size in a manner that the grain runs with the surface. A smooth-grained wood is required. The primary tool is a knife, supplemented by gouges for removing large areas. The knife is inserted into the block on a slight slant when cutting to ensure that the line or section to be eliminated will be smaller at the bottom, so that the remaining woods have a wider base. The knife is drawn toward the body as it makes a cut. An opposite angle of cut is made to ease the removal of wood between the lines which of course now forms a trench. As much as desired cuts may be done for large areas with a gouge and followed by finishing touches. The block is thereafter cleaned with a rag moistened with benzene or other cleaning fluid. A dampened cloth is used to remove all traces of ink of design or drawing and a soft brush is used to sweep off ruminant particles in the cuts.

#### **1.2.4 Glass**

Glass is a hard non crystalline material that is usually clear and transparent. The glassy state is due to the random arrangement of its atoms rather than the regular patterns characteristic of crystals.

### **Glass making**

The basic steps in glassmaking are mixing, melting, forming and annealing. Most glasses are composed of silica plus the oxides of boron, aluminum, sodium, potassium, calcium, magnesium, lead, barium and lithium. These ingredients from sand in its purest form are mixed together in a mechanical mixer for uniform distribution. In addition to these combined ingredients called batch granules of scrap glasses called cullet are added; melting of the ingredients at a temperature of about 1400°C follows to help remove bubbles and streaks. Dropping the temperature to a range between 1100°C to 1300°C makes the viscosity of the batch to be suitably formed. The melting of almost all the glass

is done in a continuous tank furnace. Mixed batch materials are usually loaded into the back of the furnace and molten glass flows steadily out at the front.

Glass formed is achieved at specific temperature. Mostly a red-hot taffy of molten glass is delivered to a forming machine. Forming is carried out at a temperature in which the glass is able to flow. An appreciable force is applied at the temperature range to shape the glass as desired. The forming techniques could be by blowing, pressing or drawing, rolling, floating process, casting, hand forming. Bottles, flasks and other hollow thin-walled products are blown. Thick walled glass products are pressed e.g automobile headlight lenses while drawing is used to produce tubing, rods and sheets.

### 1.2.5 Procedure for constructing glass apparatus

A diamond is used to cut glasses into sizes. Proper measurement is required with the use of a tape rule and maker on the glass. A ruler is placed on the mark and a trace of kerosene is run along the mark with a soft brush or foam. A diamond is thereafter held by its handle, placed at one end of the mark and run through the marked line to effect cutting of the glass. This exercise requires a great deal of patience and carefulness.

### Self Assessment 5

Describe glass forming technique

Glass blowing is the unique method of glass forming technique. It involves inflating molten glass into a bubble with the aid of a blowpipe, or blue tube as invented by the Phoenicians about 50BC along Syro-palestinian coast. Evidence of glassblowing in the past was from a collection of waste from a glass workshop (ie fragments of glass tubes, glass rods and tiny blown bottles) which were dumped in a mikvah (Jewish ritual bath between 37 and 4 BC) some of the glass tubes recovered are fired closed at one end and are partially inflated by blowing through the open end while still hot to form small bottle. There exist two major methods of blowing glass such as

1. Free blowing: this involves the blowing of short pulls of air into a molten position of glass known as 'gather' which has been spooled at one end of the blowpipe. The glassworker can quickly inflate the molten glass to a coherent blob and work it into a desired shape.



2. Mold blowing: involves the use of glob forming an elastic skin on the interior of a glass blob which matches the exterior caused by molten glass placed on the

end of the blow pipe. This is then inflated into a wooden or metal carved mold. Thus, the shape and texture of the bubble of glass is determined by the design on the interior of the mold. Single-piece mold and multi-piece mold are frequently used to produce mold-blowing vessels.

### **1.3 Conclusion**

You have learned from this unit the importance of measurement in construction of apparatus. The unit also exposes you to the procedures and skills required in constructing specific science laboratory apparatus particularly wooden and glass apparatus.

### **1.4 Summary**

This unit critically analyzed the function of measurement as a concept. It stated that measurement is associated with quantities, units and dimensions. It was also indicated in this unit that data collection plans are usually necessary before embarking on construction of objects. Likewise the unit gave consideration to valued and non-valued add steps for any process. It was briefly stated that the use of tools can bring about improvement among workers. Finally, specific procedures involved in constructing as well as glass apparatus (free blowing and mold blowing) were discussed.

### **1.5 Tutor marked assessment**

List the major tools required in glass blowing

### **1.6 References/Further Readings**

- Bansal, N.P. (1986) silicate glass technology methods. Krieger  
Bret, P. (1987) Industrial studies. A workbook for building craft students London: Stanley Thrones  
Encyclopedia Americana International Edition (12) scholastic library publishing Inc Connecticut  
Encyclopedia Americana international edition (29) scholastic library publishing, Inc Connecticut  
Goodman, W.L (1964) The history of wood working tools. London: G.Bell and sons, Ltd  
Jam, H. (1989) current trends in the science and technology of glass. World scientific pub.  
Stephen H (2004) Application of tools in six sigma available on line [www.wdpc.co.uk](http://www.wdpc.co.uk)  
Retrieved on 30/6/2015  
Tangerman, E.J. (1985) complete crude to wood carving sterling  
Welsh P.C (2008) wood working tools 1600-1900 (EBook #-7238) Available on line [www.gutenberg.net](http://www.gutenberg.net)

## **UNIT 2 ART WORK**

- 2.1 Objectives
- 2.2 Main content
  - 2.2.1 Lettering
  - 2.2.2 Colour
  - 2.2.3 Painting
- 2.3 Conclusion
- 2.4 Summary
- 2.5 Tutor marked assessment
- 2.6 References/further reading

### **2.0 Introduction**

This unit will expose you to the concept of lettering (typography) and the rudiment of sketching letters and numbers. You will be led to identifying colour (light and pigment) and colour mixture for painting. The unit will also guide you to be able to design instructional topic/ title to enhance your classroom engagements.

### **2.1 Objectives**

On completing the study of this unit, you should be able to:

1. Explain precisely lettering as a concept
2. Sketch letters and numerals in type faces
3. Mix colours
4. Design sign writing

### **2.2 Main content**

#### **2.2.1 Lettering**

Lettering (Typography) is simply the art and techniques of arranging types for making written language readable and appealing at the same time. In order to arrange type, some selections of typefaces point size, line length, leading (line spacing), letter spacing (tracking) and adjusting the space within letters pairs (kerning are carried out). Pipe (1997) confirmed that typography has been put in film, television and online in modern time.

Typography as coined from the Greek '*typos*' (forms) and '*graphein*' (to write) has its origins in the punches and dies used in making seals and currency in ancient times. A lot of innovations have been injected into typefaces invention. Movable wooden type system was manufactured from ceramic materials and day. Metal type was invented in Korea during the Goryeo Dynasty at about 1230. The lead-based alloy produced by Gutenberg is still suited for printing purposes to date. This digital computer permits designers to create more experimental typefaces alongside the practical font of traditional Typography. Text in traditional typography is collected to create a readable, coherent, and visually satisfying whole. Such text works invisibly, without the awareness of the reader. Intentionally, even distribution of typeset material, with a minimum of distractions and

anomalies, is aimed at producing clarity and transparency. Choice of typeface(s) is the primary aspect of text typography—[prose fiction](#), [non-fiction](#), editorial, educational, religious, scientific, spiritual and commercial writing all have differing characteristics and requirements of appropriate typefaces and fonts. For historic material established text typefaces are frequently chosen according to a scheme of historical *genre* acquired by a long process of accretion, with considerable overlap between historical periods.

In contemporary use typography covers all aspects of letter design and application both mechanically (eg typesetting and type design) and manual (eg handwriting and calligraphy).

### Self Assessment 1

Briefly differentiates the forms of typefaces in existence.

The following are the possible categories of typefaces:

1. the black letter otherwise referred to as Gothic was designed in imitation of the popular hand lettering style of scribes
2. Roman typeface: was developed through the Greek lapidary letters. The roman lapidary letters forms transitioned into the monumental capitals that provide insight into the foundation of another typeface called serif typefaces.
3. Text typeface: this is composed to create a readable coherent and visually satisfying whole that work visibly, without the awareness of the reader.

Most contemporary books are set with state-of-the-art seriffed ‘text roman’s. Sans serif text fonts are often used for introductory paragraphs as well as whole short articles. Any form of typeface chosen must be legible (ie considering perception) and readable (ie in terms of comprehension). Below are samples:

SCHOOL OF EDUCATION, NOUN  
school of education, noun

*SCHOOL OF EDUCATION, NOUN*  
*school of education, noun*

*SCHOOL OF EDUCATION, NOUN*  
*school of education, noun*

SCHOOL OF EDUCATION, NOUN  
school of education, noun

**SCHOOL OF EDUCATION, NOUN**  
**school of education, noun**

**SCHOOL OF EDUCATION, NOUN**  
**school of education, noun**

*SCHOOL OF EDUCATION, NOUN*  
*school of education noun*

**Self Assessment 2**

Practicing the rudiment of lettering

Typeface designers are primarily concerned with the legibility of a text to ensure that each individual character or glyph is unambiguous and distinguishable from all other characters in the font. The same is the concern of the typographer in selecting a typeface with appropriate clarity of design for the intended use at the intended size. In the same vein typographers or information designers show concern for the readability of the text. Readability is the intended result of the complete process of presentation of textual material in order to communicate meaning which proves to be unambiguously. Text can be set in lower case (small letters) which is more legible than text set all in upper case (capitals), presumably because lower case letter structures and word shapes are more distinctive.

Obtain a 2B exercise booklet and select 3 boxes each vertically and horizontally as a block. Use a ruler and your pencil, sketch letter A

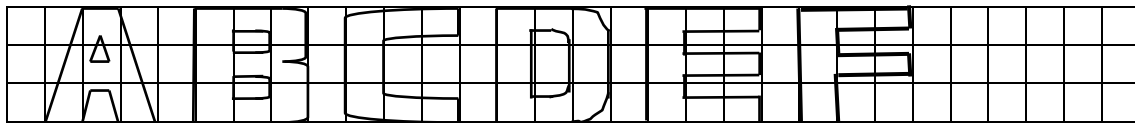

If your sketch resembles the type shown above proceed to sketch other alphabets to Z, otherwise make another trial before proceeding. Similarly, on another page of the booklet, try to produce the lower case of the alphabets and numeric of different typefaces.

**2.2.2 Colour**

In typography, colour is the overall density of the ink on the page. This is determined by both the typeface and word spacing as well as leading and depth of the margins. The combination of text layout, tone or colour of text, interplay of text with the white space of the page and other graphic elements impart a feel or resonance to a subject matter.

**Self Assessment 2**

What are colour harmonies?

Colour harmony can be achieved by using colours which are nearer each other on colour wheel. There exists monochromatic and analogous harmonies, monochromatic

armonies 9ie single colour) is achieved when shadings of different intensities of the same colour are made on a sketched diagram.

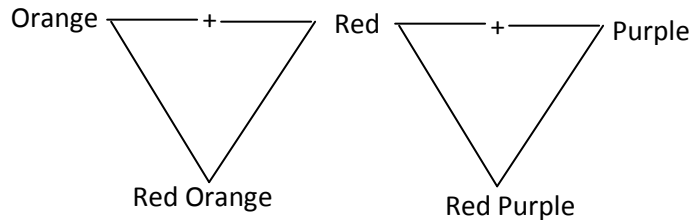

Analogous harmony however is obtained when adjacent colours on the colour wheel are mixed to produce another colour.

### 2.2.3 Painting

When white light rays fall naturally on any physical object, two possible reflections of the rays is made. It is either all the colours in the white light are reflected from the object when it appears white or only some of the colours are reflected while others are absorbed. The colour which the object shows to the eye is the colour of light reflected. This means for example the green colour appearing on most leaves of plants in an indication of the reflection of green light and the absorption of other colours.

### Self Assessment 3

Analyse the primary light and pigment colours and their possible derivable colours.

Primary colour is one which cannot be obtained by mixing two or more colours. The primary coloured light are Blue, Green and Red (BGR) while that for coloured pigment are blue, Red and yellow (BRY) secondary colour is always obtained by mixing two or more colours together.

- Red + Green = Yellow
- Red + Blue = Magenta
- Blue + Green = Cyan

Complementary colours are colours that produce white light when added together as in the following mixtures

- Red + Cyan = White
- Green + Magenta = White
- Blue + Yellow = White

This may be displayed in a Venn diagram as shown below

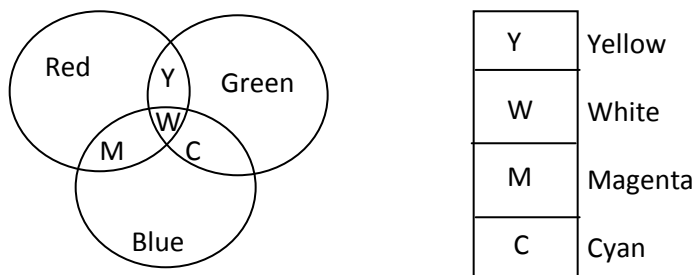

There is a slightly different features produced however when coloured pigments are mixed together. A pigment is a substance that imports colour to paints, inks, chalks, crayons etc. mixing of coloured pigments in common use are impure colours. Consider the elementary separation of colour in black ink through paper chromatography using a strip of white paper on which a spot of black ink is impressed at some I am to the apex. When the tip of the strip close to the ink spot is in contact with ethanol, the strip absorbs the ethanol which dissolves the component colours in the ink and transfers them to different locations as it flows up the strip. This means that all coloured pigments are impure. The process of obtaining different colour when two or more colours are mixed together is known as colour mixing subtraction.

### **2.3 Conclusion**

This unit has enabled you to understand the concept of typography. It has also lead you to be able to sketch type faces of alphabets and numbers. You can now shade objects based on the features of colour harmonies. Similarly, the unit differentiates coloured pigment and light and their derivatives.

### **2.4 Summary**

This unit has precisely defines typography as the art and technique of arranging type for making written language readable and appealing. Different forms of typefaces were stated as blackletter, Roman, text and their sub components. It is indicated in this unit that a 2B exercise book is a good working material for sketching alphabets or numerics for any of the typefaces. Colour harmonies categorized into monochromatic and analogous were differentiated precisely. The unit how colour are mixed together in painting; that it is possible to form secondary colours from primary colour and complementary colours from a mixture of primary and secondary colours.

### **2.5 Tutor Marked Assessment**

1. Construct a colour wheel
2. Select a topic in integrated science (eg Reproduction in Animals /Atomic structure/Heat transfer) and using any type face of your choice write the selected topic on a piece of cardboard.

### **2.6 References/Further Readings**

- Brmghurst, R. (2005). *The Elements of typographic style version 3.1* Canada; Hartley and Marks
- Jury, D. (2006). *What is Typography?*. Mies, Switzerland: Rotovision. 63.
- Man, J. (2002). *The Gutenberg Revolution; The story of a Genius and an invention that changed the world*, London: Headline Review
- Pipes, A. (1997). *Production for Graphic Designers (2<sup>nd</sup> Ed)*. Prentice Hall
- Reynolds, L. (1988). "Legibility of type" *Baseline* 10



## **UNIT 3: METAL WORKS**

3.1 Objectives

3.2 Main content

3.2.1 Crystal structure effect on metal

3.2.2 Structural materials in metal works

3.2.3 Material fabrication

3.2.4 Welding

3.2.5 Metal working tools and welding techniques

3.3 Conclusion

3.4 Summary

3.5 Tutor marked assessment

3.6 References/further reading

### **3.0 Introduction**

You will learn in this unit the effect of crystal on the properties of metals, the forms of materials available and the properties of materials for fabrication. The unit will also examine specific welding techniques.

### **3.1 Objectives**

After studying this unit you should be able to:

1. list the effect of crystal structure on the properties of metals
2. identify the structural materials in common use in metal work
3. give the properties of materials used in fabrication
4. describe welding

### **3.2 Main Content**

#### **3.2.1 Crystal Structure Effect on Metal**

All metal is composed of minute particles called crystals. These grains usually form around a nucleus in a pure metal when it begins to freeze from liquid to solid. Thus the free atoms of such metal arrange into space lattice. As much as heat is extracted from a liquid metal, the crystals grow outwards from the nucleus until they form the grains.

#### **Self Assessment 1**

What are the effects of crystal structure on the properties of metal?

1. Effect of cold working: a metal is cold worked when hammered, pressed, rolled drawn or bent. When a metal is hammered for instance by applying a force, the crystal of the metal is altered and its grains become elongated in the direction of working.

This cold working or hardening brings about a stiffening of the material that becomes harder with time, less ductile and less malleable rather with increased tensile strength. The fine grains can be restored if the cold worked structure is heated to a temperature at which it will re-crystallize.

2. Hot working: this occurs above the re-crystallization temperature of a metal. The temperature must not be too high or too low to prevent grain growth or work hardening respectively. This technique allows for the manufacture of structural sections. Less power to deform the metal is required because it becomes softer, more plastic and malleable. A fibrous flow of all wrought sections are produced from the hot rolling. Forging can as well be applied in hot working process. Typical hot rolled sections are plates, beans, columns, angles, channels, and tees.

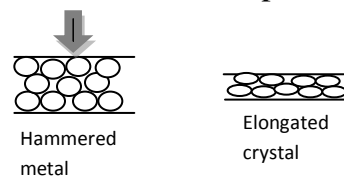

### 3.2.2 Structural Materials in Metal Works

Basically, two forms of structural materials commonly used in metal work are discussed in this unit.

1. Beans and columns

The aims of rationalizing hot rolled steel section to achieve greater economy in steel construction have been known to include:

- (a) The need to concentrate on universal beans and columns
- (b) Provision of lighter and more efficient joists in smaller sizes.
- (c) Providing roll channels and angles with square toes that will facilitate welding etc.

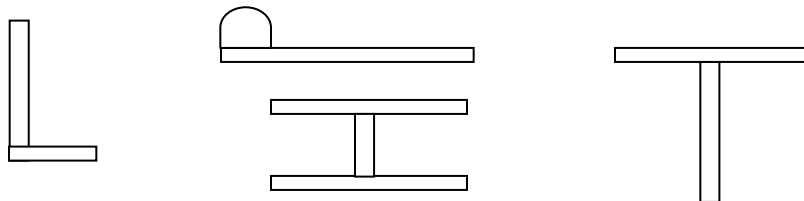

2. Plates

This results when hot rolled flat plate is rolled into different sizes in the form of imperial or metric. Such plates may therefore be cut into required lengths and widths having reasonably squared the edge.

### 3.2.3 Materials for Fabrication

Most materials used for fabrication are metals with low content of carbon. Other elements may include sulphur, phosphorous, silicon hydrogen, Nitrogen, Niobium, oxygen, Nickel etc.

## Self Assessment 2

State the properties of materials used in fabrication.

1. Low carbon steel (LCS) is the most widely used materials for fabrication because of its desirable working properties. The composition of steel determines the properties. For instance iron imparts ductility, malleability, plasticity, magnetism, softness and elasticity but readily forms oxides that cause rusting as well as scaling when heated red. However when a non-metallic carbon is added to the iron, steel is produced which helps to increase the hardness and tensile strength of the steel.
2. Low alloy steel (LAS)
3. Austenitic stainless steel.

### 3.2.4 Welding

The most commonly technique employed in joining pieces of metals is welding. There could be the need to join thick or thin sections. For very thick sections, elctro-slag, consumable nozzle, submerged arc and electro-gas techniques are used. Thin plates are otherwise joined by employing metal are gas shielded carbon (IV) oxide and manual metal arc. Lap joints on thin plates are done through resistance welding where as axy-acetylene welding is used in thin sections in most car repairs.

## Self Assessment 3

Why is it necessary to paint gas cylinders with specific colour?

The principle of painting gas cylinder with specific colour scheme ensures the identification of the nature of the gas content of the cylinder. Thus, yellow colour sheme on cylinder indicates that the gas contained in it should either be toxic or poisonous gas. A red or maroon colour scheme on a cylinder reveals an inflammable gas as the content of the cylinder. Paintings of aluminum panel on cylinder body can as well be identified to show up special markings or identification labels.

## Self Assessment 4

Identify the zones in oxy-acetylene flame acetylene is composed of hydrogen and carbon.

It is carbon that provides the intense heat and very high flame temperature ( $3100^{\circ}\text{C}$ ) which burn with oxygen. If the oxygen is insufficient, carbon burns by given off black sooty smuts into air. Acetylene has a reasonable proportion of carbon which provides a flame of excess carbon when oxygen is turned down. The carbon which is taken into steel provides a high carbon surface used for hard surfacing operation.

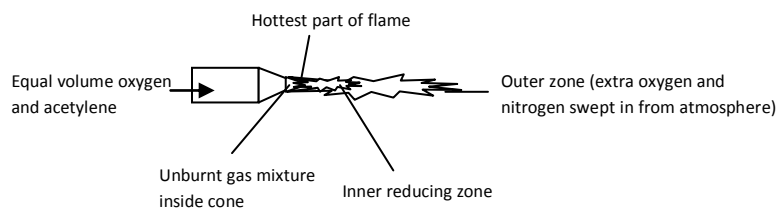

As the operator works on metals, three possible flames may be released:

- (a) Neutral flame: this burns equal quantities of oxygen and acetylene
- (b) Carburizing flame: This has an excess of acetylene which results in a carbon-rich zone extending around and beyond the cone
- (c) Oxidizing flame: This has an excess of oxygen that produces an oxygen-rich zone just beyond the cone. This is made possible by setting to neutral and then turning the fuel gas down.

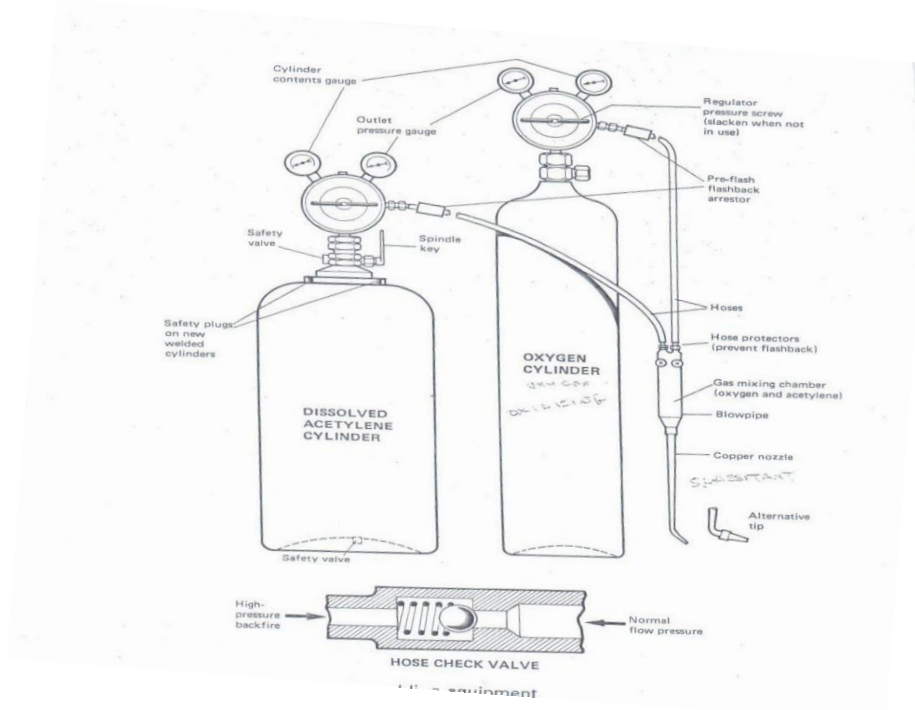

### Self Assessment 5

Outline the components of oxy-acetylene welding systems.

- (1) A supply of dissolved acetylene stored in steel cylinders which contain a porous substance (charcoal) and a solvent (acetone) for the gas
- (2) A supply of oxygen gas in alloy steel cylinders charged to a pressure of 172.5 bars. A manifold that contain both oxygen and dissolved acetylene may be used.
- (3) Pressure regulators for the gases to reduce the cylinder pressure to a suitable value for welding.
- (4) Rubber canvas hose and their special connections
- (5) Blowpipe with set of nozzles
- (6) Special tinted welding goggles.
- (7) A spark lighter.

### 3.2.4 Metal Working tools and Welding Techniques

Metal working hand tools are used in the metalworking workshop and basically are powered solely by the operator. Other tools are powered by electricity. The projects in metalwork involve construction and application of shaped figures on thing gauges of sheet metal. Attempt is made here to give a guideline to enable each student produce a useful item. The basic operations in metalwork (ie, cutting and filling) are put into consideration. Also, all the knowledge gained in geometrical construction is the basis of metalwork projects. The metalwork jobs that have been worked on or beaten can be finished by polishing. Polishing is carried out on metals to help:

- (1). form protective coating,
- (2). prevent rusting,
- (3). make the material wear longer and
- (4). make the material look nice as a finished product

The processes involved in surface finishing for metals include:

- (a). Buffing,
- (b). Scratching and brushing
- (c). Spot finishing
- (d). Copper finishing
- (e). Lacquering
- (f). Hammered finishing
- (g). Enameling
- (h). Tinning and plating
- (i). Painting
- (j). Red lead finishing
- (k). Bronzing and galvanizing.

### Self Assessment 6

Identify metalworking tools

The following are metalworking tools



Bench Vices



Bench Grinder



Drill press vices



Metal cutter



Drilling Machine



Hacksaws



Power hacksaws

## Self Assessment 7

Discuss three welding techniques

Welding is any process in which two or more pieces of metal are joined together by the application of heat or pressure or a combination of both. There are two categories of welding process which are:

1. Pressure welding: The weld is achieved by pressure
2. Heat welding: The weld is achieved by heat.

However, brazing and soldering are other means of joining metals.

Today welding is a process that replaced bolting and riveting of old in construction of bridges, buildings and ships. It is a basic process in the automotive and aircrafts industries as well as in the manufacture of machinery.

- a. Gas welding: This involves the use of heat from a gas flame which is applied directly to the metal edges that are to be joined. As the heat is applied, a filler metal or welding rod is melted to the joint. The surfaces to be welded and the welding rod are coated with flux to shield the material from **\*our** which could cause defective weld.
- b. Arc welding: This involves continuous supply of either direct or alternating current onto the edges of the metals to be joined. Fluxes are not necessary but electrodes are used. Examples include shielded metal arc, gas tungsten arc, gas-metal arc, and submerged arc.
- c. Resistance welding: This involves using heat obtained from the resistance of metal to the flow of electric current. For this to be done electrodes are clamped on each side of the parts to be welded and such parts are subjected to great pressure while a heavy current is applied briefly. The resistance of the metals causes heat that melts the metals and creates the weld, eg in automatic or semiautomatic machines.
- d. Thermite welding: This involves generating heat from chemical reaction in which mixture of aluminum powder and iron oxide (the thermite) is ignited. This causes the aluminum to **\*limit** with the oxygen to generate heat that releases liquid steel from the iron. This liquid steel serves as filler metal for the weld. This welding is applied in rail, breaks or seams in heavy iron and steel sections.
- e. Laser and Electron beams welding: These devices produce high-quality welding products at rapid rate. They are applicable in automotive and aerospace industries.



## Self Assessment 8

Explain how you can be able to build an object with a metal plate

To build an object with a metal plate, one needs to be:

- (i) familiar with various types of technical drawing used in the metal construction.
- (ii) understand basic calculations used in the metal construction.
- (iii) aware of various measuring methods using appropriate tools, eg: rulers, tapes, height gauges and calipers.

- (iv) knowledgeable in identifying the difference between a material list and cutting list.
- (v) familiar with the various types of methods used for flat pattern development, eg: parallel line, radial line triangulations development methods.
- (vi) familiar with structural type of joint connections.
- (vii) conversant with identifying and application of the various production instructions.

The steps involve:

### 1. Shape Development

This is the making of patterns of various shapes. This can either be through: drawing the shape of the object on paper and then transferring it to the sheet metal by placing a carbon paper below the paper and retracing on the metal or by drawing the shape directly on the sheet metal. This method involves measuring and scribing the lines, circles, angles and curves directly on the sheet metal, e.g, developing a box:

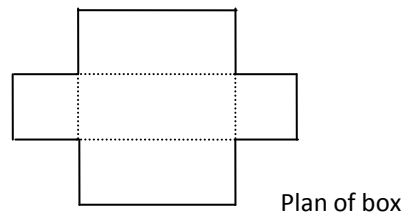

### 2. Metal Joining

There are four ways of joining pieces of metals together. They are by soldering, welding, riveting and through mechanical fasteners like bolts and nuts as well as screws.

#### **Metal joining by soldering**

This is the process of joining metal surfaces by means of an alloy called solder which has a lower melting point than the metals being joined. This can be by soft soldering, hard or silver soldering and brazing. When the solder melts below red heat, it is called soft soldering but when it melts at or above red heat, it is called hard soldering or brazing. The tools and materials used in soldering include: soldering bit which is also called copper bit, solder, flux, source of heat and emery cloth or file.

#### **Application of Solder**

All joints should be carefully prepared beforehand. The surfaces of the parts to be soldered must be very clean, free from rust, dirt and grease. These factors coupled with the correct choice of solder are largely responsible for the success and strength of the joint. After the bit has been heated and lined, apply the solder sparingly using only enough to cause the metal pieces of the joint to unite and bind together. Then move the bit slowly along the joint to enable the heat from it travel by conduction to the work. The heat supply should be constant and adequate to allow the solder to run freely.

### **3.3 Conclusion**

You have learned in this unit the effect of crystal structure on the properties metals. The structural materials used in metal work and the properties of materials used in fabrication were also discussed. You were also exposed to elementary welding procedure.

### **3.4 Summary**

This unit identified the effect crystal structure on the properties of metal to include cold working and hot working. The unit also gave the forms of structural materials used in metal work to include beams and columns as well as plates. The aims of rationalizing hot rolled steel section were stated with respect to the need to concentrate on universal beams, provision of lighter and more efficient joist in smaller sizes and the provision of roll channels and angles. The materials need for fabrication was identified and the common techniques for joining metals was describe as welding.

### **3.5 Tutor Marked Assessment**

Pay a visit to a road side welding workshop and write a short report on:

1. the tools/equipment used for welding
2. the raw materials required
3. the likely precaution necessary as welding takes place.

### **3.6 Reference/Further Readings**

Bob Whittier (1999). *"The Fine Art of Metal Shaping," Part 2. Experimenter Magazine.*

Encyclopedia Americana International Edition 28. Scholastic library publishing, Inc  
Connecticut

Howard, B. C. (1998). *Modern Welding Technology*, 4th edition, Prentice-Hall.

Kenyon, W. (1979). *basic welding and fabrication* London: Pitman

White, K. (2009). "The Slapper, Spoon, Spike and Forming Stump." Booklet, published by TM  
Technologies.



## **UNIT 4: SIMPLE ELECTRONIC CIRCUITS**

- 4.1 Objectives
- 4.2 Main content
  - 4.2.1 Elementary electronics
  - 4.2.2 Components of electronic device
  - 4.2.3 Electrical circuit
  - 4.2.4 Simple radio
- 4.3 Conclusion
- 4.4 Summary
- 4.5 Tutor marked assessment
- 4.6 References/further reading

### **4.0 Introduction**

In this unit, you will learn that simple electronic circuits are very important components of large gadgets. You will be able to sketch a simple circuit diagram and able to construct a simple radio.

### **4.1 Objectives**

At the end of studying this unit, you should be able to

- (1) describe an electronic device
- (2) Identify the components of a simple electronics.
- (3) Sketch circuit diagram
- (4) Construct a simple radio

### **4.2 Main content**

#### **4.2.1 Elementary electronics**

Electronics are devices or circuits designed with such components as vacuum tube, integrated circuits or transistor. The prime movers in electronics are the electrons. Electrons are tiny particles within atoms that move around defined paths called the circuits carrying electrical energy. A moving electrical charge is electricity. Electricity is all about making electromagnetic energy flow around a circuit so that it will drive devices like electric motor or heating element or powering appliances like electric cars, kettles, lamps etc.

Electronics is a much more subtle kind of electricity in which tiny electric currents (simple electrons) are carefully directed around much more complex circuits to process signals or store and process information. Information is stored in two different ways namely: analog (conversion of information into kind of instant, chemical panting) and digital (conversion of information into stored numerical coded version). Electric equipment works basically on information in either or digital format. A transistor radio of old had antenna sticking out of its case that receives broadcast signals. Such analog signals may be in the form of radio waves, travelling through the air from a radio transmitter at different frequencies that depicts exactly those words or music they carry.

The radio thus keeps signals in analog form as the signals are being received, boosts such signals and converts them into sound again for any listener to hear. In digital radio however, the signals travel as coded numbers. When such numbers are received by a radio, they are converted to into sound signals. Most modern devices use digital electronics e.g computer, cell phone, hearing aids, televisions, digital camera etc.

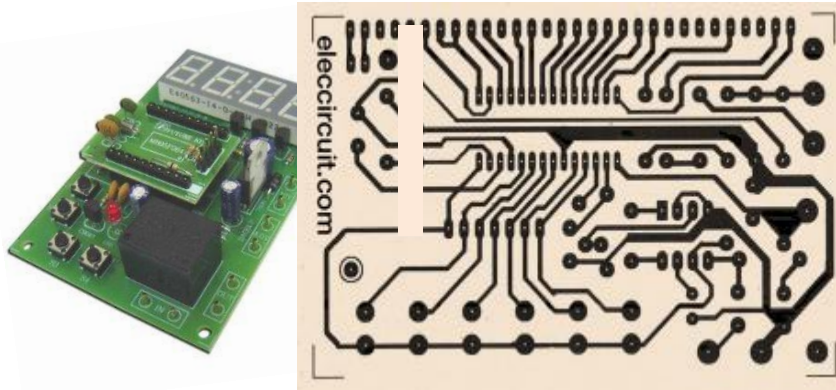

#### 4.2.2 Components of Electronic Device

The circuits inside pieces of electronic device are packed with components that do different jobs. The components are linked up to one another by cables or printed metal connections.

#### Self Assessment 1

Identify and describe the most important electronic components.

Semi conductor is a group of materials that has a resistivity about ten million times higher than a good conductor eg copper.

These are basis of all integrated circuits and micro processors. There are two forms of semiconductors which are

- (i) Intrinsic semiconductors-these are just the material that is timely a semiconductor in its own right without anything added. Heating the device can allow sufficient electrical conduction.
- (ii) Extrinsic semiconductors-these are semiconductors to which a very small amount of impurity has been added. This replacement of a very minute part of an atom is called doping. The addition of impurity atom increases the conductivity of the substance (eg germanium or silicon) two types of semiconductors made by doping include:
  - (a) N-type-in which doping is done with a pentavalent materials as phosphorus
  - (b) P-type-for which doping is through a trivalent material eg aluminum.

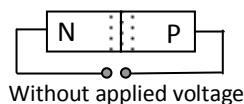

(1) Resistors: are simplest electronic circuit components. Resistors restrict the flow of electrons and reduce the current or voltage through the conversion of electrical energy to heat. Resistors can be of different sizes or shapes. Variable resistors (potentiometer) have dial control used in changing the amount of resistors is used in volume controls in audio equipment. The unit of resistor is the 'ohm' ( $\Omega$ )

(2) Diodes are simple forms of vacuum tubes, usually referred to as electronic valve. A diode consists of two elements called electrodes (cathode and anode). Electrons are emitted by cathode while anode collects them.

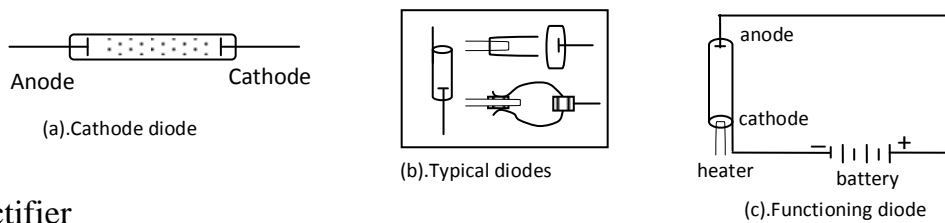

### Diode as rectifier

Diode functions as rectifier since it shows a difference in its forward and reversed bias properties. There are half-wave and full-wave rectification.

### Zener diode

This is a diode that was breakdown voltage when operated in a reverse direction. The voltage across the diode remains constant over a range of reverse current limited by resistor to prevent overheating that may ruin the diode. This serves a useful function as voltage stabilizer circuits.

### (3) Transistor

When two junction-diodes are joined back-to-back, they form a semi conductor triode called a transistor. It consists of a thin central layer of one type of semi conductor between two relatively thick pieces of the other type. Junction transistors are of two types

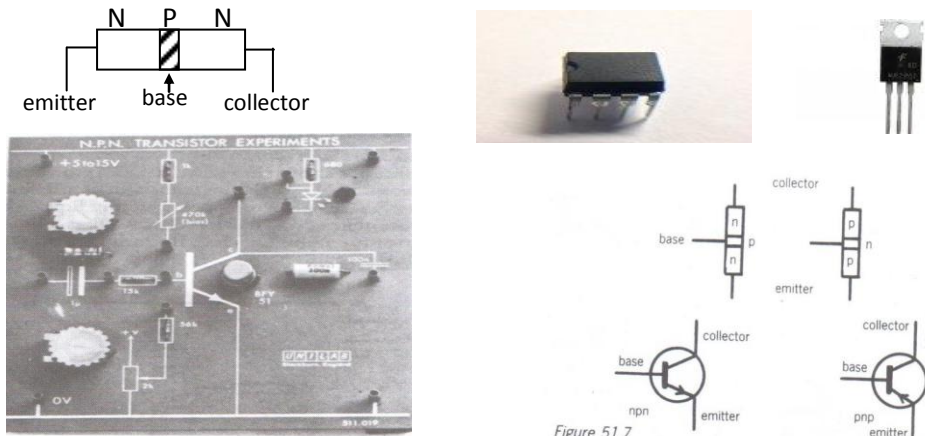

#### (4) Thermistor

This is a semiconductor device with varied resistance as the temperature changes. They are made from metal oxides (eg nickel and manganese) and may include:

- (i) Negative Temperature Coefficient (NTC) thermistors and
- (ii) Positive Temperature Coefficient (PTC) thermistors

These devices have applications in such devices as:

- (a) overload protection in a razor socket (eg, PTC). This functions when a circuit heats up and the resistance of the thermistor rises rapidly to cut off the current
- (b) water temperature sensor in car or an ice sensor on aircraft wing surfaces (eg, NTC)
- (c) body alarms (eg, NTC) in which air flowing from an air bed cools a thermistor while the body is moving and breathing. An alarm will sound if the baby stop breathing and air stop flowing which causes a heat-up of the thermistor.

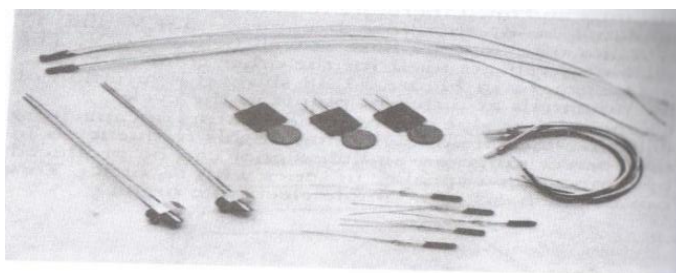

*Thermistors (STC)*

#### 4.2.3 Electronic Circuit

It is the part provided for the easy passage of electric current from a source of power (a cell or battery) and back to the source. There are two categories:

- (1) Open circuit- this is a circuit for which no resistor is connected and no current flow. In this kind of circuit, the electromotive force (emf) and the potential difference (Pd) across the terminal of a cell are same in magnitude.
- (2) Closed circuit- this is a circuit in which a resistor is connected to the terminals and current flows. The potential difference (pd) of a cell is less than its (emf) due to the fact that part of the voltage is being used to drive the current through the cell itself.

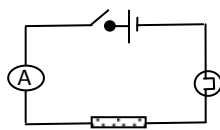

Open circuit

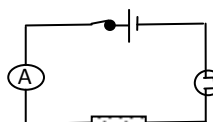

Closed circuit

#### A cell/battery

A cell consists of two electrodes which are immersed in an electrolyte, usually of dilute acid ( $H_2SO_4$ ). A chemical reaction takes place between the electrolyte and the electrodes with the result that one of the electrodes acquires a positive potential and the other acquires a negative potentials. A battery consists of a number of connected electrochemical cells which convert

chemical energy into electrical energy. A torch battery is made up of at least two dry cells where as a car battery is made up of six cells. There are two types of batteries.

1. Dry battery or power packs.
2. Wet battery.

Any of these batteries can be made of primary cells or secondary cells. A primary cell battery cannot be recharged once it has been used up, e.g, torch battery. A secondary cell battery can be recharged, e.g, car battery. This battery is also called an accumulator. Accumulators are of two types such as lead-acid type and nickel-cadmium type.

### Lead-Acid Accumulator

This has lead oxide as the positive plate and lead as the negative plate. These plates are interleaved and separated from one another by ebonite separators. The plates are put inside a glass or plastic container and surrounded by an electrolyte or dilute sulphuric acid (tetra-oxo-sulphate (VI) acid)

### Nickel-Cadmium Accumulator

The positive plate in this accumulator is made of nickel hydroxide; the negative plate is a mixture of cadmium and iron oxides while the electrolyte is potassium hydroxide.

### Maintenance

1. Dry batteries should not be left for a long time inside appliances which are not in use.
2. Dry batteries should be kept in a dry place and clean up the casing to avoid corrosion.
3. When the electrolyte in a wet battery is weak, it is necessary to refill it with a fresh electrolyte after emptying the battery.
4. Charge the wet battery by passing a direct current through it from the positive terminal to the negative terminal with the aid of a charger
5. Carry out a battery test once a week using a hydrometer, a reading of 1.28-1.30 specific gravity indicates a reliable battery.

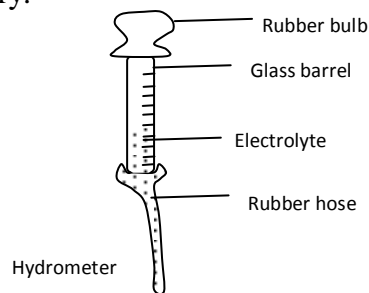

## SELF ASSESSMENT 2

Differentiate series and parallel circuits

A circuit-in-series is the arrangement of electrical components in a way that they follow one another in a simple loop in which the same magnitude of current flows through the various components.

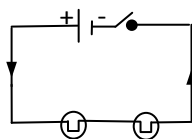

Similarly, circuit-in-parallel is one in which the components are connected across those already in the circuit. This has more than one path available for current to flow.



### **SELF ASSESSMENT 3**

Why should an electronic device be installed with a fuse?

A fuse is a short length of wire of low melting point connected to the ‘live’ wire of an electric circuit. It function automatically in opening a circuit (ie cut of current flow) whenever excess current might damage the wiring or the appliance connected to it. Fuse function as a safety device that protects electrical components in the circuit from serious destruction due to excessive current flow. Fuses have ratings. The ‘fuse rating’ is the maximum safe current permitted to flow in it before its breaks.

### **SELF ASSESSMENT 4**

What is a capacitor and why is it necessary in electronic devices?

A capacitor is a device or storing charge. van Musschenbroek of Leyden (1746) invented the earliest capacitor (Nelkon and Parker, 1995). All capacitors consist of two plates separated by an insulator called dielectric, oil or air or polystyrene. Capacitors are necessary in electronics and telecommunications as they play significant roles in radio and television receivers and in transmitter circuits.

Through technological advancement, pinhead capacitors are made from Coltan (Columbite-tantalite), a black tar-like mineral deposited in DR Congo and a critical component for the production of electronics. Such capacitors regulate voltage and store energy as essential components of mobile phones, laptops and other electronics.

#### **4.2.4 Simple Radio**

A simple radio can be built on a wooden base of specific size or dimension with following items. A collection of fahne-stock clips with screws are obtained; a 36 s.w.g enameled wire made into a coil about 100 turns in a former (ie a tube) is equally gathered along with a variable capacitor, a semi-conductor diode, an earphone or headphone and a ceramic capacitor 0.01N

#### **4.3 Conclusion**

This unit has simplified what an electronic device is as well as identifies the components of electronic circuits. You have also learned from this unit the types of

circuits available in the study of electronics. Finally, the unit led you to try out building a mini radio.

#### **4.4 Summary**

This unit is all about electronics as devices designed with such components as vacuum tube, integrated circuits or transistor. It was stated that the prime mover in electronics are the electrons. The unit gave the components of electronic devices as: resistor, diode, transistor, thermistor, capacitor etc. you also discovered that there are two types of circuits such as circuit-in-series and circuit-in-parallel as well as closed and open circuits. The unit exposes you to the role of a fuse in electrical circuits. Discussion in this unit led you to connect some electronic components to produce a device that can receive signals from audio transmission station.

#### **4.5 Tutor Marked Assessment**

Visit a road side electronics workshop and write a report on how the layout of the components on the mother board in a radio makes it to serve its purpose.

#### **4.6 References/Further Readings**

Bueche, F ( ) principles of physics fourth edition. McGraw Hill

Gibbs, K. (2011) Advanced physics second edition Cambridge university press

Gibilisco, S. (2011) Teach yourself electricity and electronics Mc Graw Hill.

Woodford, C. (2008) Electronics Available online Retrieved on 2/6/2015  
[http://www.explain that stuff.com/electronics](http://www.explainthatstuff.com/electronics).

Nelkon M. & Parker P. (1995) Advanced level physics seventh edition New Delhi: CBS

[www.eleccircuit.com](http://www.eleccircuit.com) Available online. Retrieved on 29/6/2015

## **UNIT 5: SAFETY IN INTEGRATED SCIENCE WORKSHOP**

5.1 Objectives

5.2 Main content

5.2.1 Safety

5.2.2 Safety measures in the workshop

5.2.3 Safety gear

5.2.4 Safety rules

5.3 Conclusion

5.4 Summary

5.5 Tutor marked assessment

5.6 References/further reading

### **5.0 Introduction**

This unit will take you through the various precautions and rules guiding the use of tools on the works you carry out in the workshop. The precaution signs in the workshops will be displayed and safety gears will also be discussed.

### **5.7 Objectives**

At the end of studying this unit, you should be able to:

1. identify the possible safety signs in an Integrated science workshop
2. state the precautions necessary with the use of tools in the workshop
3. outline the safety measures in the workshop.

### **5.2 Main Content**

#### **5.2.1 Safety**

Safety is the state of being safe. It is the state of being protected from physical, social, emotional or occupational consequences of failure, damage, error, accidents or harm. Safety is also viewed in terms of the control of recognized hazards to achieve an acceptable level of risk. Such control could be in the form of protecting workers in a workshop from events or exposure to phenomenal that may cause health or economical losses. Charles (2009) considers safety as a condition of a steady state of an organization doing what it is supposed to do, in-term of public codes, standards operational plans and personal policies, etc. To him safety is a normative concept for any organization, large or small. He affirms that safety complies with situation-specific definitions of what is expected and acceptable. Safety can be limited with reference to some guarantee or standard of insurance to that of the quality and un-harmful function of a tool or workshop. Considering safety as a relative term it reveals that eliminating all risk would be extremely difficult and if possible very expensive to sustain. Thus, a science workshop is such where risks of injury or devices damage are low and manageable.



## **SELF ASSESSMENT 1**

What are the possible safety options in a workshop?

- (1) Normative safety: this is a form in which a product or design of a device meets applicable standards and practices for its construction irrespective of the safety history of the product.
- (2) Substantive safety: this is otherwise referred to as objective safety which implies that real-world safety history is favourable whether or not standards are met.
- (3) Perceived safety: otherwise referred to as subjective safety is all about using level of comfort and perception of risk without concern for standards or safety history.
- (4) Social safety: alternatively considered as security addresses the risk of harm due to intentional criminal acts eg assault, vandalism etc.

### **5.2.2 Safety Measures in the Workshop**

The Scientists works are not free of hazards in totality. They thus devise various means to protect themselves by:

1. Wearing overalls (eg, coats).
2. Wearing safety goggles over their eyes to protect the eyes from hazardous substances, fumes, light and heat.
3. Not wearing loose dresses like mantle, head tie/scarf, 'hijab', etc, which may expose them to danger when in contact with bunsen flames or dangerous chemicals.
4. Not applying hair spray (oil sheen, conditioner, gels) due to the risk of flash-out fire resulting from solvent evaporation.
5. Keeping away from naked flames when heating substances and ensuring that the open end of the container in which substances are heated is not pointing to any person.
6. Cleaning instruments used for works regularly in order to prevent contaminations.

In spite of all these precautions, the inevitability of accidents calls for formulating temporary care modalities for victims in the form of a first aid. First aid is an intermediate temporary relieve care given to someone who has been injured or suddenly taken ill before medical attention.

If electric shock should happen, the victim should be kept warm, relieved of pain and try to control bleeding. Should any cut happen to the skin in the cause of using a sharp object, the spot is cleaned carefully with cotton soaked in methylated spirit and covering it with a thin layer of cotton; iodine tincture should be applied to the spot. Should fire occurs, this can be put off using sand or the extinguisher. The extinguisher can be used on flammable liquid, gaseous, fire or electric equipment. The procedure is first pull out the pin at the handle to free the hose. Squeeze the levers then aim at the fire base.

Safety measures in the science workshops are collective responsibilities of teachers and learners. They are the entire precaution requisites considered within a workplace to improve safety. It is all the effect made to ensure reduction in risks related to human health. Most often, safety measures in a workshop may include any of the following relative to the job; training of workers or product users, stress testing , visual examination for flaws, statements of ethics,

physical examinations, periodic evaluation, root cause analysis, internet safety, drug testing etc. Quite reasonable category of standard organizations exist whose responsibility is basically to promulgate safety standards; such organizations include American National Standards Institute (ANSI), in Nigeria there exists NAFDAC, NLDEA, EFCC, FEPA etc.

## SELF ASSESSMENT 2

Identify precaution signs in the workshop

The following are possible precaution signs which guide against preventable accidents while using any tool in a workshop.



### 5.2.3. Safety Gear

Safety gear is any mechanism, device or equipment available for use should unexpected happens. Some important things to consider about safety gear include:

1. its accessibility: every gear must be placed within the reach so it is always easily visible and available for immediate use either by you or visitors; especially close to individual tools and machines.
2. its being in good condition: any gear that has spent its time should be discarded and grab another pair from the safety equipment bin. If they are dirty, clean them with microfiber cloth to make them almost as good as new, and costs less. When the splitter on the saw is not align with the blade, take your time to align it, or order a replacement in case it is too bent to fix. Keep spare safety equipment around in case something fails, instead of continuing on without the safety gear.

3. its pleasure to use: you need to find safety gear that you like to use at work, eg: a pair of good safety glasses, a high quality hearing protector or a vapor mask.
4. its reliability: making any safety gear the first thing you touch when entering your shop and the last thing that comes off when you leave the shop must your habit, eg wearing safety glasses.

### **SELF ASSESSMENT 3**

Identify the common personal safety gears found in a workshop?

Some of the personal safety gears needed in a workshop are:

- (i) Anti-Fatigue & Anti-skid mats: these gears may have the greatest footing since a concrete shop floor can make workers legs and back tired too sooner. These mats keep workers safe as well as protect edged tools (or your handplane) that may drop accidentally.
- (ii) Dust Mask: it is obvious that cutting wood produces dust, which floats in the air. Such dust is often collected by the lungs and nasal passages. Too much exposure to non-toxic wood dust can cause chronic (long term) allergies.
- (iii) Fume Mask: it is known that some solvents and finishes are irritating to an extent that some can affect one's consciousness. A sealed fume mask with the proper canisters for the solvents or materials the workers are using keeps these irritants away from the lungs and bloodstream.
- (iv) Hearing Protectors: when workers are exposed to noise they become tired just as labour does. Such noise comes from many of the power tools in the shop, both small and large. Their output has damaging intensity and frequency of sound, eg routers and tablesaws
- (v) Push sticks: always ensure that you hold work with push sticks or handscrew when working with spinning blades on Saws, Router tables, jointers and other tools. You will protect your hand from accidental saw cuts.
- (vi) Safety Glasses: since vision is so crucial when using tools and accident may be inevitable, it necessary the workers wear them. Safety glasses protect workers eyes from *chemical* injury, so use them when cleaning brushes, mixing chemicals together, welding objects, etc.
- (vii) Shop clothes: these are safety items because they will not get tangled in the machines. One will not be so worried about bleeding over the shop clothes when got hurt in addition to helping to avoid dirtying one's good clothes. Long sleeves and pants are known to provide armor which help protect skin from splinters and from flying debris (shattered knots anyone) from power tools and chemical splashes. Good boots equally protect workers feet from the dropped razor-sharp chisel, a falling piece of wood or random sharp trash on the floor.

#### **5.2.4 Safety Rules**

Without mincing works before we attempt or engage in any practical work within the workshop premises, we ought to understand some fundamental safety rules. These set of rules further entrench the habit to keep uses of tools in a workshop safe. Possible rules for safety generally may include:

1. follow all procedures, understand all signs and read all precautions.
2. tools are to be used only in the workshop.
3. tools must be used for only the purposes sanctioned by the teacher.
4. use the appropriate tool for the right work
5. no horse plays in the workshop instead walk around.
6. no food should be stored in the workshop; nothing should be tasted or eaten and no smoking!
7. any accident or noticed faults on fittings must be reported at once to the teacher.
8. keep the floor and workbench clean and dry always and do not sit on tables/workbench.
9. protective coat must be properly worn in the workshop, e.g, coat, nose mask, hand glove, etc.
10. learners should be familiar with hazard signs.

These safety rules and regulations should be written on cardboards and mounted on the wall close to the entrance door.

## **SELF ASSESSMENT 4**

Which major parts of human body are desired for protection as we work in the workshop?

Working in the workshop with the use of different tools involves a variety of risks, it is vital that we protect our eyesight, hearing, limbs and appendages, respiratory system, the sense of touch, the skin etc.

### **5.3 Conclusion**

In this unit, you have learned the various precautions and rules guiding the use of tools on the works you carry out in the workshop. You as well take notice of from the unit the precaution signs in the workshops and got adequate discussions on safety gears.

### **5.4 Summary**

The unit has classified safety as a normative concept for organizations and defined it as a state of being safe. Among the safety measures in any workshop were given as wearing of overall, keeping away from naked flames, cleaning the tools, etc. Pictures of precautions signs were shown. Features of safety gears were given to include: reliability, accessibility, etc and finally, safety rules listed.

### **5.4 Tutor Marked Assessment**

Outline some possible hazards in a workshop and possible means of averting them.

## **5.6 References/Further Readings**

Allsignage.com (2014)

Charles, G.O. (2009) Blue Ember Technologies LLC: safety versus security in fire protection planning. The American institute of Architects: knowledge communities available on retrieved in June 30, 2015

Wildavsky, A. & Wilavsky, A. (2008) Risk and safety. In David R.H Concise Encyclopedia of Economics (2<sup>nd</sup> Edition) Indianapolis: Library of Economics and Liberty