

## **COURSE GUIDE**

### **PHY 113 HEAT AND PROPERTIES OF MATTER**

**Course Team**      J. S. O. Oludotun (Course Developer/Writer) -  
Distance Learning Institute, University of Lagos  
Akoka Lagos  
Dr. Sanjay Gupta (Course Editor) – NOUN  
Dr. Sanjay Gupta (Programme Leader) – NOUN  
Kayode S. Olubiyi (Course Co-ordinator) – NOUN



**NATIONAL OPEN UNIVERSITY OF NIGERIA**

National Open University of Nigeria

**Headquarters**

University Village  
Plot 91, Cadastral Zone,  
Nnamdi Azikiwe Express way  
Jabi, Abuja

Lagos Office  
14/16 Ahmadu Bello Way  
Victoria Island, Lagos

e-mail: [centralinfo@nou.edu.ng](mailto:centralinfo@nou.edu.ng)

website: [www.nou.edu.ng](http://www.nou.edu.ng)

Published by  
National Open University of Nigeria

Printed 2017

ISBN: 978-058-485-4

All Rights Reserved

<b>CONTENTS</b>	<b>PAGE</b>
Introduction.....	iv
What You will Learn in this Course.....	v
Course Aims.....	v
Course Objectives.....	vi
Working through this Course.....	vii
Course Materials.....	vii
Study Units.....	vii
Textbooks and References.....	ix
Assignment File.....	ix
Presentation Schedule.....	ix
Assessment.....	x
Tutor-Marked Assignment .....	x
Final Examinations and Grading.....	x
Course Overview.....	xi
How to Get the Best from the Course.....	xii
Facilitators/Tutors and Tutorials.....	xiv
Summary.....	xv

## INTRODUCTION

Energy, undoubtedly, affect all facets of human life. Energy in form of heat is intimate to our existence. It is used to cook foods, light houses and to operate machines. In this way, it is very important to learn about it. On the other hand, matter is a substance which has certain mass and occupies certain volume. As you know, this matter can exist in solid, liquid and gaseous state. Each of these states has distinct and various properties based on interatomic and intermolecular forces. For example: a solid has definite shape, size and volume, a liquid has no definite shape for possesses a definite volume and a liquid has neither definite shape nor volume. When you go through the material of PHY 113 Heat and Properties of Matter, you will find that solid state of matter exhibits elastic properties, liquid state of matter accounts for surface tension and viscosity and the gaseous state of matter accounts for pressure, diffusion etc. Therefore, this course introduces to you the concepts of Heat as well as Properties of matter.

Heat and Properties of Matter is a subject of great interest for our undergraduate students. This is a one semester 2-Credits core course. It will be available to all students to take towards their B.Sc. Physics, B.Sc. Education and other programmes like B.Sc. Computer Science, Environmental Studies etc. This course comprises 20 Study Units in 4 Modules which involves basic principles of heat and properties of matter. The themes of these topics we have chosen are most interesting and relevant in our day-to-day life. The material for this subject has been developed in such a way that student with at least a credit pass at the Ordinary Level or equivalent will follow quite easily. This course will expose the students to the concepts of heat and properties of matter besides the practical applications of these concepts in our daily life.

There are no compulsory pre-requisite for the course. However, you are strongly advised to have adequate knowledge for Further Mathematics or Applied Mathematics for clear understanding of this subject.

This Course Guide you briefly what the course is about, what course materials you will be using and how you can work your way through those materials. It suggests some general guidelines for the time you are likely to spend for complete it successfully. It also provides you guidance on Tutor-Marked Assignments (TMAs) which will be available on the Web in due course. There are regular tutorials classes that are linked to the course.

You are advised to attend these sessions regularly as this is an important aspect. Details regarding the time and locations of tutorials and

practical will be available at your Study Centre and included on the Web.

## **WHAT YOU WILL LEARN IN THIS COURSE**

The overall aim of PHY 113 is to introduce the basic principles, concepts and the relevance of heat and properties of matter and appreciate the usefulness of these principles and concepts to make our life simpler and convenient. During this course, you will learn that what is the concept of temperature? How heat is related with temperature and how it can be measured? What are the different gas laws? What are the different modes of transfer of heat in different substances of matter? Our quest to answers these and other related questions is contained in the subject of heat.

So, in the beginning of this course, you would learn about the concept of temperature, its measurement, gas laws, thermal expansions and molar heat capacities of gases. Also, you learn about the different states of matter i.e. solid, liquid and gases. In this way, the concept of heat is treated first in this course.

Towards the second part of this course, you will be introduced in detail the various aspects of properties of matter like elasticity, density, buoyancy, viscosity, surface tension and so on. You will not only read about these concepts and principles in our daily life.

## **COURSE AIMS**

The aim is to introduce you to the basic principles and concepts of heat and properties of matter and how to make use of these principles and concepts and their applications in everyday life. This will be achieved by:

- Introducing you to the basic principles and concepts of heat and properties of matter,
- Demonstrating for you how these basic principles and concepts can be used in our day-to-day life situations,
- Explaining some phenomena associated with heat and properties of matter,
- Stimulating your interest in this area for the betterment of the world through advancement of technology, and
- Giving you some insight into possible future developments in the areas of material science and engineering, metallurgy, in all types of mechanical devices such as steam engines, electric power plants and automobiles etc.

## COURSE OBJECTIVES

To achieve the aims set out above, the course sets over all objectives. These course objectives tell you what the entire course is all about and to let you know what you have to achieve at the end of the course. In addition, such unit has specific objectives. The unit objectives are always included at the beginning of a unit; you should read them carefully before you start working through the unit. You may refer to them during your study of the unit to check your progress. You should always look at the unit objectives again after completing a unit. In this way, you can be sure that you have done what was required of you for the unit.

Mentioned below are the wider objectives of the course as a whole. By meeting these objectives, you should have achieved the aims of the course as a whole.

On successful completion of the course, you should be able to:

1. Explain the concept of temperature and to differentiate between temperature and heat,
2. Define different temperature scales and to explain their relation with each other,
3. List the different types of thermometers and their thermometric properties,
4. Define and explain the different
5. Describe thermal expansion in solids and liquids
6. State and explain different gas laws;
7. Define molar heat capacity of a gas at constant pressure and constant volume;
8. Define the thermal conductivity of a good conductor and insulator and their measurement;
9. Explain the meaning of convection as a mode of transfer of heat in fluids;
10. Explain the nature of radiation of heat;
11. Explain the existence of molecules in matter and to measure the size of a molecule of a chosen liquid;
12. Define the concept of stress and strain and their relation;
13. Define young's Modulus, Shear Modulus and Bulk Modulus of elasticity;
14. Derive an expression for pressure of a gas in an enclosed system and then explain the concept of root mean square velocity of gas molecules;
15. Explain the concept of density and relative density and the determination of density for different shaped objects;
16. State Archimedes Principle;

17. Define pressure exerted by a solid or fluid and its determination;
18. State Bernoulli's Principle and its applications;
19. Explain the concept of Viscosity; and
20. Explain the concept of surface tension and the determination by capillary rise.

## WORKING THROUGH THIS COURSE

To complete this course you are required to go through the study units, read set books and read other materials provided by NOUN. You will also need to do some practical exercises which will be arranged by your course facilitator/tutor. Each unit contains self-assessment exercise, and at points in the course you are required to submit assignments for assessment purposes. The evaluation of your TMAs will be done by the facilitators/tutors at the study centre. At the end of the course, there is a final examination. The course shall take you about 15 weeks in total to complete. Below you will find listed all the components of the course, what you have to do and how you should allocate your time to each unit in order to complete the course successfully and on time.

## COURSE MATERIALS

You will be provided with:

1. Course Guide
2. Study Units
3. Assignment File
4. Presentation Schedule

## STUDY UNITS

There are 20 Study Units in this course. The names of these units are as follows:

### Module 1

Unit 1	Concept of Temperature
Unit 2	Types of Thermometers
Unit 3	Heat Measurements
Unit 4	Thermal Expansions
Unit 5	Gas Laws

### Module 2

Unit 1	Molar Heat Capacities of Gases
Unit 2	Conduction of Heat

Unit 3	Convection
Unit 4	Radiation
Unit 5	Molecular Properties of Materials

### Module 3

Unit 1	Elastic Property of Matter
Unit 2	Moduli of Elasticity
Unit 3	Kinetic Theory of Gases and Application
Unit 4	Density
Unit 5	Buoyancy – Archimedes Principle

### Module 4

Unit 1	Pressure
Unit 2	Elements of Hydrodynamics
Unit 3	Viscosity
Unit 4	Surface Tension
Unit 5	Other properties of Gases

Each study unit consists of three hours work. Each study unit includes introduction, specific objectives, directions for study, reading materials, conclusions, summaries of key issues and ideas and references for further reading. The unit objectives tell you what the entire unit is all about. The units direct you to work on exercise related to the required readings. Each unit contains self-assessment exercise (SAQs). In general, these self-assessment questions are based on the materials available in the units and will help you to gauge your progress and to reinforce your understanding of the material. Together with tutor-marked assignments (TMAs), these exercises will assist you in achieving the stated learning objectives of the individual units and of the course.

### TEXT BOOKS AND READINGS

Soars, F. W., Zemansky, M.W. and Young, H. D. (1980). *College Physics Addison* – London: Wesley Publishing Company.

Nelson and Parker, *An Advanced Level Physics*; Published by British Library Publication.

Zemansky, M. W., *Heat and Thermodynamics*, McGraw Hill, New York.

Wilkinson, J. (1983). *Essentials of Physics*, Australia: McMillan Education Publishers.



Tyler, F., *Heat and Thermodynamics*, London: Edward Arnold Publisher Limited.

Flowers, B. H. and Mendoza, E. (1970). *Properties of Matter*, London: John Wiley and Sons Limited.

Noaks, M. A. (1963). *New Intermediate Physics*, Canada: Macmillan and company Limited.

Garg, S. C., Bansal R. M., and Gosh C. K. (1993). *Thermal Physics*, Published by Tata McGraw – Hill Publishing Company Limited, India.

Feynman, R. P., Leighton, R. B. and Sands, M. (1971). *The Feynman Lectures on Physics*, California: Addison – Wesley Publishing Company Limited.

Awe, O. And Okunola, O. O. (1986). *Comprehensive Certificate Physics*, Ibadan: University Press.

Ference, M. (Jnr.), Lemon, H.B. and Stephenson, R. J. (1970). *Analytical Experimental Physics*, Chicago: The University of Chicago Press.

## **ASSESSMENT FILE**

The assignment file will be supplied by NOUN. In this file, you will find all the details of the work you must submit to your facilitator/tutor for marking. The marks that you obtain in your assignments will be counted in your final result you obtain for the course. Further information on assignments will be found in the assignment file itself and later in the course Guide in the section on assessment. Therefore you are advised to take your assignments seriously and regularly. Before submitting, you must ensure that you have answered all the questions require from you in all assignments. The assignments will cover all the topics treated in all the units.

## **PRESENTATION SCHEDULE**

The presentation schedule included in your course materials gives you the important dates for the completion of tutor-marked assignments and attending tutorials. Remember, you have to complete the assignments in time and submit these stipulated assignments by the due date.

## ASSESSMENT

There are two aspects to the assessment of your performance for the course. First are the tutor-marked assignments; second, there is a written examination. In doing the assignments, you are expected to apply information, knowledge and techniques gathered during the course. The assignments must be submitted to your facilitators/tutor for formal assessments in accordance with the deadlines stated in the presentation schedule and the assignment file. The work you submit to your facilitator/tutor for assessment will carry 30% weightage of your total course work. At the end of your course, you need to appear for a final written examination of three hours duration. The final examination will carry 70% weightage of your course mark.

## TUTOR-MARKED ASSIGNMENT

The TMAs are listed as item 6.0 in each unit. The main aim of assignments is to test your comprehension of the material provided to you and to help you by providing feedback to you. Generally, you will be able to complete your assignments from the information and materials contained in the study units of the course and other recommended books. Using other references will give you a broader viewpoint and provide a deeper understanding of the subject.

On completion of each assignment, send it, together with a TMA form, to your facilitator/tutor.

Make sure that each assignment reaches your facilitator/tutor on or before deadline mentioned by the course coordinator in the presentation schedule and assignment file. If, for any reason, you can not complete your work on time, contact your facilitator/tutor before the assignment is due to discuss the possibility of an extension. Extensions will not be granted after the due date unless there are exceptional circumstances.

## FINAL EXAMINATIONS AND GRADING

The final examination for PHY 113 will be of three hours duration and carry a weightage of 70% of the total course grade. The examination will consist of questions which reflect the type of self-testing practice exercise and tutor marked problems you have previously encountered in each unit of the course. **All areas of the course assessed. It is required that you must pass in assignments and term-end examination of a course separately.**

You are advised to use the time between finishing the last unit and sitting the examination to revise the entire course. You might find it

useful to review your self-test, tutor-marked assignments and comments on them before appear in examination.

## COURSE MARKING SCHEME

The assessment will be two folds – TMAs will carry 30% weightage of course marks while the final examination will carry 70% marks of the total marks obtainable.

## COURSE OVERVIEW

The table given below brings together the units, the number of weeks you should spend to complete them, and the assignments that follow them.

Unit	Title of Work	Week's Activity	Assessment (End of Unit)
	Course Guide	Week 0.5	
	<b>Module 1</b>		
1	Concept of Temperature	Week 0.5	Assignment 1
2	Types of thermometers	Week 0.5	Assignment 2
3	Heat Measurement	Week 1.0	Assignment 3
4	Thermal Expansion	Week 0.5	Assignment 4
5	Gas Laws	Week 0.5	Assignment 5
	<b>Module 2</b>		
1	Molar Heat Capacities of Gases	Week 0.5	Assignment 6
2	Conduction of Heat	Week 1.0	Assignment 7
3	Convection	Week 0.5	Assignment 8
4	Radiation	Week 0.5	Assignment 9
5	Molecular Properties of Materials	Week 0.5	Assignment 10
	<b>Module 3</b>		
1	Elastic Property of Matter	Week 0.5	Assignment 11
2	Moduli of Elasticity	Week 0.5	Assignment 12
3	Kinetic Theory of Gases and Applications	Week 1.0	Assignment 13
4	Density	Week 1.0	Assignment 14
5	Buoyancy- Archimedes Principles	Week 0.5	Assignment 15
	<b>Module 4</b>		
1	Pressure	Week 0.5	Assignment 16
2	Elements of Hydrodynamics	Week 0.5	Assignment 17
3	Viscosity	Week 0.5	Assignment 18
4	Surface Tension	Week 1.0	Assignment 19

5	Other Properties of Gases	Week 0.5	Assignment 20
	Revision	Week 2.0	
Total		15 Weeks	

## HOW TO GET THE MOST FROM THE COURSE

In distance learning, the study units replace the lecturer. This is one of the great advantages of distance learning; you can read and work through specially designed study materials at your own pace, and at a time and place that suit you best. Think of it as reading the lecture instead of listening to a lecture. In the same way that a lecturer might set you some reading to do, the study units tell you when to read your set books or other materials, and when to undertake computing practical work. Just as a lecturer might give you an in-class exercise, your study units provide exercise for you to do at appropriate points.

Each of the study unit follows a common format. The first item is an introduction to the subject matter of the unit and how a particular unit is integrated with the other units and the course as a whole. Then, there is a set of learning objectives. These objectives let you know what you should be able to do by the time you have completed the unit. You should use these objectives to guide your study. When you have finished the unit, you must go back and check whether you have achieved the objectives. If you make a habit of doing this, you will significantly improve your chances of passing the course.

The main body of the unit guides you through the required reading from other sources. It will enhance your understanding of the material in the unit. Self-tests are interspersed throughout the units and answers are given within the units. Working through these tests will definitely help you to achieve the objectives of the unit and prepare you for the assignments and the examination. It is advised that you should do each self-tests as you come across in the study unit. There will also be numerous examples given in the study units; work through them when you come to them, too.

The practical strategy for working through the course is mentioned below. If you have any trouble, telephone your facilitator/tutor or post the question on the Web CT OLE's discussion board. Remember that facilitators are to help you. Here, you will get an opportunity to discuss with them your problems pertaining to the courses of your study. So, when you need help, don't hesitate to consult your facilitator to provide it.

1. First of all, read the Course Guide carefully and thoroughly.
2. Then, organize a study schedule. Refer to the course overview for more details. Note the time you are expected to spend on each unit and how the assignments relate to the units. Important information's regarding the details of your tutorials and the date of the first day of the semester is available from the Web CT OLE. You need to gather all the information in one place, such as your diary or a wall calendar. Whatever method you choose to use, you should decide on and write in your own dates for working on each unit.
3. Once you have created your own study schedule, do everything you can to stick to it. The major reason that students fail is that they get behind their course work. If you have any differently with your schedules, please let your facilitator/tutor know before it is too late for help.
4. Turn to **Module 1**, Unit 1 and read the introduction and the objectives for the unit. Assemble the study materials. You will almost always need both the study unit you are working on and of your set books on your desk at the same time.
5. Work through the unit. The content of the unit itself has been arranged to provide a sequence for you to follow. As you work through the unit, you will be instructed to read section of your set books or other articles. Use the unit objectives to guide your readings.
6. Update yourself on the Web Ct OLE. Up-to-date information will be continuously posted there.
7. Keep in mind that you will learn a lot by doing the assignments carefully. The assignments have been designed to help you to meet the objectives of the course and, therefore, will help you pass exam. Submit all assignments by due date.
8. Review the objectives for each study unit to confirm that you have achieved them. If you feel unsure about nay of the objectives, review the study materials or consult your facilitator. After ensuring that you have achieved a unit's objectives, then start on the next unit. Proceed unit-wise through the course and try to keep yourself on schedule.
9. When you have submitted an assignment to your facilitator/tutor for marking, do not wait for its return before starting on the next

unit. The evaluated assignments will be returned to you with tutor comments and marks obtained in TMAs. Keep to your schedule. When the assignment is returned, pay particular attention to your tutor's comments, both on the tutor-marked assignment form and also written on the assignments. Consult your facilitator/tutor as soon as possible if you have any questions or problems.

10. After completing the last unit, give sometime to review the course and prepare you for the final examination. Check that you have achieved the unit objectives listed at the beginning of each unit and the course objectives listed in the Course Guide.

## **FACILITATORS/TUTORS AND TUTORIALS**

There are 5 hours of tutorials provided in support of this course. You will be notified of the dates, time and location of these tutorials, together with the name and phone number of your facilitator/tutor, as soon as you are allocated a tutorial group. Your facilitator/tutor will evaluate and comment on your assignments, keep a close watch on your progress and on any difficulties you might face and provide assistance to you during the course. You must mail your tutor-marked assignments to your facilitator/tutor well before the due date (at least two working days are required).

They will be marked by your facilitator/tutor and returned to you with comments at the earliest.

Do not hesitate to contact your facilitator/tutor by telephone, e-mail, or discussion board if you need help. The following might be circumstances in which you would find help necessary. Contact your facilitator/tutor if:

- If you do not understand any part of the study units or assigned readings.
- You have the difficulty with the self-tests or exercises.
- You have a question or problem with an assignment, with your tutor's comments on an assignment or with the grading of an assignment.

You should try your best to attend the tutorials. This is the only chance to have face to face contact with your tutor and to ask questions which are answered instantly. You can raise any problem encountered in the course of your study. To gain the maximum benefit from course tutorials, prepare a question list before attending them. You will learn a lot from participating in discussion actively.

## SUMMARY

PHY 113 intends to introduce basic principles, concepts and applications of Heat and Properties of Matter. Upon completing this course, you will be equipped with knowledge of concept of temperature, types of thermometers used for various purposes, heat measurements, gas laws, the different modes of transfer of heat, different properties of materials like elasticity. Also you will learn about the different properties of fluids like density, pressure, buoyancy, viscosity, surface tension etc., and their usefulness in our day to day life. You will be able to answer these kinds of questions:

1. What is the difference between temperature and heat?
2. What is Zeroth law of thermodynamics?
3. What are the different types of thermometers?
4. How latent heat of fusion is different from latent heat of vapourization?
5. What happens to a solid when heat is given to it?
6. Define molar heat capacities at constant volume and at constant pressure?
7. What are the different gas laws?
8. What are the different factors that affect the conduction of heat?
9. Is there any difference between an adiabatic and isothermal expansion?
10. Discuss the different modes of transfer of heat?
11. How convection is different from radiation?
12. State Stefan-Boltzmann law of radiation.
13. How you can measure the size of a molecule?
14. Explain the term elasticity.
15. Define young's modulus, bulk modulus and Shear modulus.
16. Derive an expression for pressure of a gas in an enclosed system.

17. Discuss the concept of Density.
18. State Archimedes Principle.
19. Derive an expression for the pressure due to the column of a liquid.
20. Discuss the applications of Bernoulli's Principle.

We hope that you will enjoy studying this course. We wish you success!



**MAIN  
COURSE**

<b>CONTENTS</b>	<b>PAGE</b>
<b>Module 1 .....</b>	<b>1</b>
Unit 1 Concepts of Temperature.....	1
Unit 2 Types of Thermometers.....	20
Unit 3 Heat Measurement .....	34
Unit 4 Thermal Expansion .....	55
Unit 5 Gas Laws .....	71
<b>Module 2 .....</b>	<b>96</b>
Unit 1 Molar Heat Capacity of Gases .....	96
Unit 2 Conduction of Heat .....	108
Unit 3 Transfer of Heat by Convection .....	127
Unit 4 Radiation.....	137
Unit 5 Molecular Properties of Materials .....	148
<b>Module 3 .....</b>	<b>160</b>
Unit 1 Elastic Property of Materials .....	160
Unit 2 Moduli of Elasticity.....	169
Unit 3 Kinetic Theory of Gases and Applications .....	184
Unit 4 Density .....	200
Unit 5 Buoyancy – Archimedes’ Principle .....	214
<b>Module 4 .....</b>	<b>230</b>
Unit 1 Pressure .....	230
Unit 2 Elements of Hydrodynamics .....	249
Unit 3 Viscosity of Fluids.....	268
Unit 4 Surface Tension .....	284
Unit 5 Other Properties of Gases .....	311

**MODULE 1**

Unit 1	Concept of Temperature
Unit 2	Types of Thermometer
Unit 3	Heat Measurement
Unit 4	Thermal Expansion
Unit 5	Gas Laws

**UNIT 1 CONCEPT OF TEMPERATURE****CONTENTS**

1.0	Introduction
2.0	Objectives
3.0	Main Content
3.1	Concept of Temperature and Heat
3.2	Concept of Temperature
3.2.1	Thermal Equilibrium
3.2.2	The Zeroth Law of Temperature
3.3	Scale of Temperature
3.3.1	Specification of Fixed Points
3.3.2	Factors for Changes in Fixed Points
3.3.3	The Temperature Scales
3.4	Specification of Interpolation
3.4.1	Definition of Temperature on Celsius Scale
3.4.2	Definition of Temperature on Fahrenheit Scale
3.5	Thermodynamic Scale
4.0	Conclusion
5.0	Summary
6.0	Tutor-Marked Assignment
7.0	References/Further Readings

**1.0 INTRODUCTION**

You will recall that the concepts of length, mass and time are regarded as fundamental quantities during the study of elementary mechanics. You also learn about derived quantities such as force, momentum and energy. In this unit, you will be introduced to another fundamental quantity called temperature.

Temperature is a fundamental quantity in the study of heat (thermal energy) or thermodynamics. Some students usually get confused with the concept of temperature and heat. Heat is a form of energy. Temperature is a sensation of hotness and coldness. Hence in this unit we shall make an attempt to differentiate between the two. We would

then explain the concept of temperature by using the zeroth law of thermodynamic. Having done this, we would then establish how the temperature of a body is measured through the use of thermometers with emphasis on their thermometric properties. In the next unit, you will learn about the types of thermometers.

## 2.0 OBJECTIVES

After the end of this unit, you should be able to:

- differentiate between temperature and heat
- define the concept of temperature
- explain the terms used for the zeroth law of thermodynamics
- state the law of thermodynamics
- define temperature scales
- solve problems on conversion of temperatures on Celsius Fahrenheit and Absolute scales.

## 3.0 MAIN CONTENT

### 3.1 Concept of Temperature and Heat

The concepts of temperature and heat are two kinds of concepts in physics that are so closely related that may confuse you as a learner in the study of physics. You need to be clear in your mind what exactly they mean.

You will remember that in your study of mechanics you learnt various forms of energy. Heat was among them. Heat measurement is usually referred to as **Calorimetry**. Also in the study of Integrated Science, you will also recall that temperature is the degree of coldness or hotness of a body. Temperature measurement in physics is referred to as **thermometry**. *Then the question arises: Why Heat a form of energy?* It is a form of energy because we use it to do work for us.

In the history of Industrial Revolution, heat engines were used to perform various kinds of work as in the textiles factories and in the locomotive engines used for transport. Besides, at home we use it for cooking and ironing our clothes.

Heat is an intangible agency that causes increase of hotness of a body. A body is said to be warmer if it receives heat and colder when it losses heat. You will therefore observe that increase in heat content of a body can be caused by any of the following ways:

- direct application of mechanical work (as in friction between two bodies);
- churning of a liquid;
- contact with a hotter body.

Heat therefore flows from a body whose degree of hotness (temperature) is greater to the body of lower degree of hotness (temperature). Consequently, it is the heat energy that is transferred and not the temperature. As a rule, when two bodies of different temperatures are placed in contact with each other, by definition, the heat lost by one body is absorbed by the other body provided the two bodies neither lose nor gain heat from the surrounding. In this case we would describe such heat energy interaction as being conserved in the system.

In this unit, we would discuss in details what is meant by temperature and how it is measured using the appropriate scales. Using the zeroth law of thermodynamics will do this. The concept of heat and its measurement will be dealt with later.

### **SELF ASSESSMENT EXERCISE 1**

Distinguish between the concepts of heat and temperature.

### **3.2 Concept of Temperature**

The concept of temperature is one of the fundamental concepts in physics. It is rather difficult to define this physical quantity as compared with, say, the length of a body. A meter is a standard length of a bar of platinum – iridium kept in Paris. We can directly copy this bar and use it to find out how many times an object is as long as this bar at anytime and place. This is not the case with temperature. Temperature is measured through an indirect method, as you will observe later in our discussion. *But the question you may ask now: What is temperature? How can we measure the temperature of a body?*

Qualitatively, temperature of a body is the degree of hotness or coldness of a body. However, this answer does not lead us to the quantitative definition of temperature or its operational definition. This is because the sensations of hotness and coldness are highly subjective. The way you feel is not the same as any other person. Other adjectives used include cold, cool, tepid, warm, etc. Using our feeling of heat to estimate degree of hotness/coldness (temperature) is very personal and very unreliable since its measurement is personal and not a standard one. Hence when we say the temperature of a body is cold, hot or lukewarm such descriptions are rather too vague to comprehend quantitatively. Consequently, an independent scale of temperature measurement is

therefore highly essential. We would now discuss how we have evolved the scale of temperature measurement.

### 3.2.1 Thermal Equilibrium

Two bodies may be at different temperature – one hot and the other cold. The hot one is said to possess more heat energy than the colder body. In another sense, the temperature of the hot body is higher than the colder body.

However, if the two bodies are now in contact with each other, heat energy flows from the hot body to the cold body until the temperatures of the two bodies are the same. The two bodies are then described as being in thermal equilibrium with each other.

Therefore, a thermal equilibrium exists between two bodies when they are in thermal contact with each other and there is no net flow of heat between them.

It is the temperature of a body that determines the direction of flow of heat from that body to another. It will flow until two temperatures are the same i.e. there is a thermal equilibrium. Once, there is a thermal equilibrium between two bodies, then it means that the two temperatures are the same – no net flow. *But now the basic question arising: How do we then define the temperature of a body quantitatively?* Let us discuss this concept.

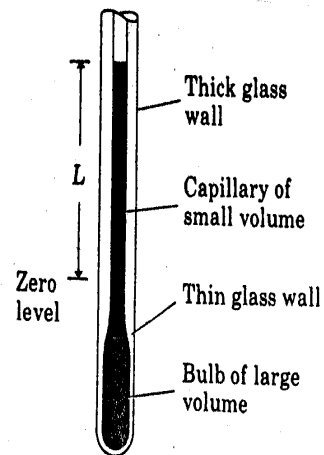
### 3.2.2 The Zeroth Law of Temperature

The zeroth law of thermodynamics helps us to quantify the concept of temperature objectively. Quantitative definition of temperature involves terms of operations that must be independent of our sense perceptions of hotness or coldness. That is, temperature has to be measure objectively and not subjectively.

It has been observed that there are some systems in which a measurable property of the system varies with hotness or coldness of the system.

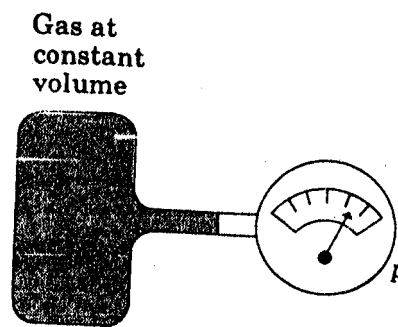
For example:

- (i) the length  $L$  of a mercury column in a thin tube will change variation in temperature (fig. 3.1).



**Fig. 3.1: A System Whose State is Specified by the Value  $L$ .**

- (ii) the pressure  $P$  of a constant volume container, measured by a pressure gauge or a manometer (fig. 3.2).



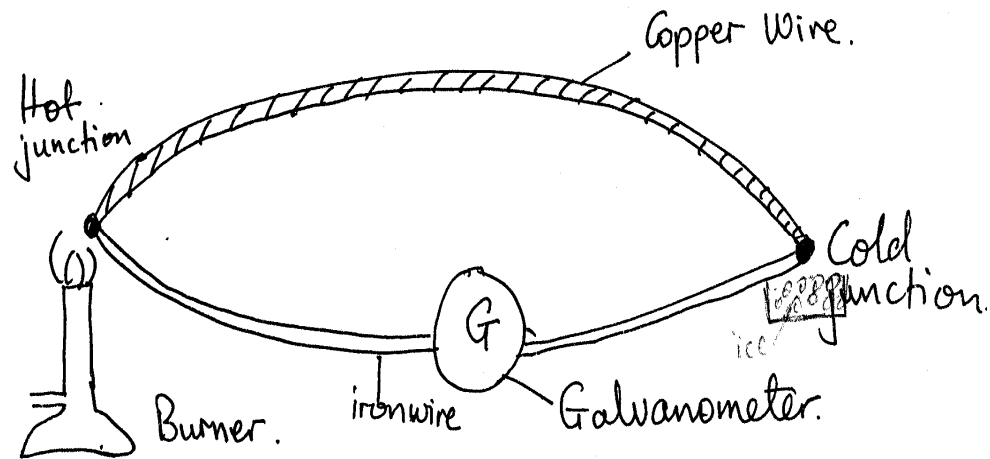
**Fig. 3.2: A System Whose State is Given by the Value  $P$  (Pressure)**

- (iii) the electrical resistance ( $R$ ) of a wire which varies with hotness or coldness as with the platinum resistance (fig. 3.3).



**Fig 3.3: Platinum Resistance**

- (iv) the electromotive force ( $E$ ) of a thermo-junction varies also with hotness or coldness of the system (fig. 3.4).

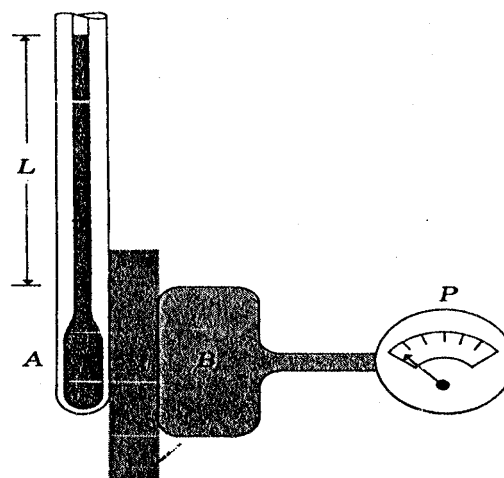


**Fig. 3.4: A Thermocouple**

In each case, discussed above the quantity describing the varying state of the system such as  $L$ ,  $P$ ,  $R$  and  $E$  are called a state of coordinate for the system.

In thermodynamics, bodies are brought into contact in order to establish the common temperature using one of these coordinates. The two bodies may be in direct contact or they may be separated by two types of wall. The types of wall are namely adiabatic and diathermic walls. Adiabatic walls are those through which no heat can be transmitted whereas the walls through which heat can be transmitted are known as diathermic walls. In thermodynamics, these two words are used to describe the process of thermal equilibrium that is, of being at thermal equilibrium. They will help you to understand the zeroth law.

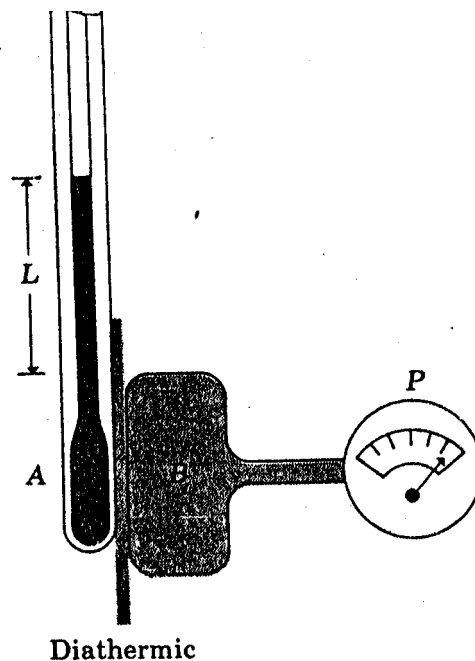
Let us consider two systems A and B such that system A is a mercury-in-glass tube with a state coordinates  $L$  and system B, a constant-volume gas container with state coordinate  $P$  (fig. 3.5).



**Fig. 3.5: Adiabatic Wall**

If system A is at a higher temperature than system B, when brought in contact with each other, then their state coordinates change. However, if the two systems are separated by insulating such as wood, plastic or fibre glass, the change in the state coordinate will be low or none. Such an insulating material is described as an adiabatic wall. Therefore, in general, an adiabatic wall is such in which, in an ideal situation, there is no change in the state of coordinates (fig. 3.5).

The opposite of adiabatic wall will then be a wall or a partition that will allow the systems A and B to influence each other (fig. 3.6).



**Fig. 6.3: A Diathermic Wall**

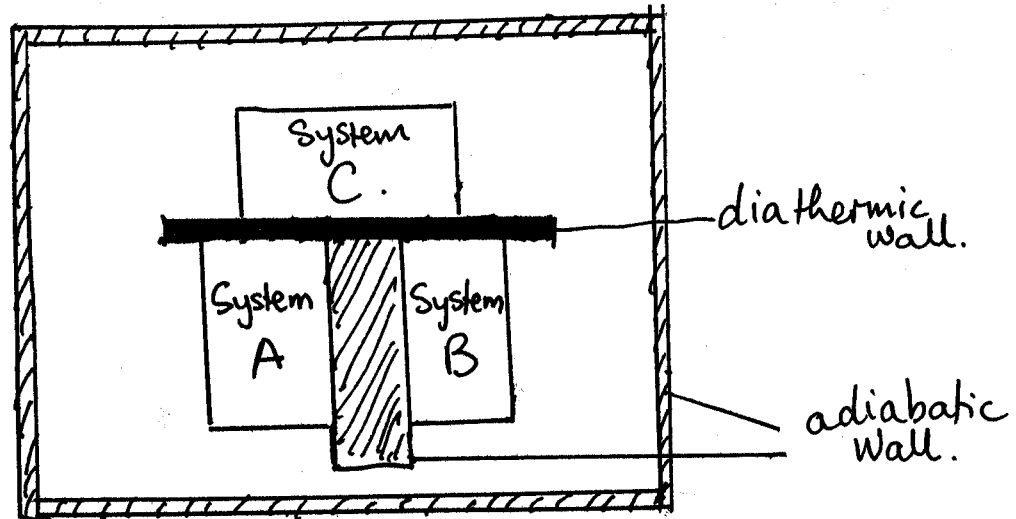
In this case it will allow free exchange of heat energy. Such a wall is called a diathermic wall. Examples of such diathermic walls are copper and aluminum. Thus when the two systems A and B are separated by a diathermic wall, initially there may be no change but eventually a state is reached when no further change in the state coordinates of A and B takes place. This joint state of both systems that exist when all changes in the state coordinates have ceased is called thermal equilibrium. Note the reduction in length of L and the increase in P of the pressure at thermal equilibrium. These changes are used to measure temperature. We would use the above illustration to explain the zeroth law of thermodynamics and subsequently temperature measurement.

### The Zeroth Law

Consider two systems A and B separated from each other by an adiabatic wall but each system is in contact with a third system C

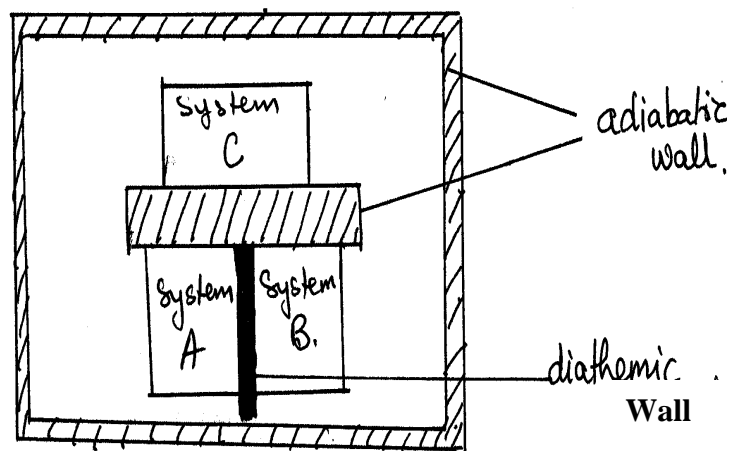


separated through a diathermic wall. Consider the whole systems surrounded by an adiabatic wall (fig. 3.7). This is to ensure that no heat energy is lost to or gained from the surrounding. Experiments have shown that systems A and B will attain a thermal equilibrium with C. If however the adiabatic wall is replaced by a diathermic wall as shown in (fig. 3.8).



**Fig. 3.7: A and B are each in Thermal Equilibrium with C**

Instead of allowing both systems A and B to come to equilibrium with C at the same time, we can first have equilibrium between A and C and then equilibrium between B and C making sure that the state of C is the same in both cases, (fig. 3.7) then A and B are brought in contact through a diathermic wall, they will be found to be in thermal equilibrium (fig. 3.8). It means that no further changes occur in systems A and B



**Fig. 3.8: A and B are in Thermal Equilibrium with Each Other.**

That is systems A and B are already in equilibrium with each other.

The above principle is called the zeroth law of thermodynamics. The zeroth law of thermodynamics states that:

***“Two thermodynamics systems A and B are separately in thermal equilibrium with a third system C, then the systems A and B are in Thermal equilibrium with each other”.***

It is called the zeroth law because the most important principles of thermodynamics have hitherto been identified as the first, second and third laws of thermodynamics. You will be introduced to these laws later in the course of your physics programme.

It is the property called temperature that determines whether or not given two systems are in thermal equilibrium. The temperature of a system is that property that determines whether or not it will be in thermal equilibrium with other system when two or more systems are in thermal equilibrium, they are said to have the same temperature. If the two systems are not in thermal equilibrium, their temperatures must be different.

The zeroth law is thus used in establishing the temperature of a body quantitatively and objectively. But before it is measured, a scale must be established with the aid of a physical property which varies with temperature – the thermometer.

We shall now consider the establishment of scales of temperatures in the next section.

### **3.3 Scale of Temperature**

There are some principles underlying the establishment of temperature scales. These principles are based on the fact that when the temperature of a body changes, all the magnitudes of almost all its physical properties also change. The condition, of course, is that this variation of properties must be linear, that is, uniform. Therefore any property of any substance that varies uniformly with temperature can be used. The variation of one of these properties is chosen to represent the accompanying change of temperature.

To measure temperature, therefore, we need to select a physical property or parameter of a chosen substance which varies uniformly with temperature. A parameter or property is a variable which is assigned a constant value during a discussion or event. As we have discussed in section 3.3.2, that some of the examples of these parameters are:

- (i) the volume of a liquid;
- (ii) the volume of a gas at constant pressure;
- (iii) the pressure of a gas at constant volume;
- (iv) the electrical resistance of a conductor;
- (v) the emf change of a thermocouple when there is a temperature difference between the junctions of a thermoelectric thermometer.

For the establishment of temperature scale, the following are required:

- (a) specification of fixed points;
- (b) specification of the method of interpolation.

Now we will discuss briefly about these concepts required for the establishment of temperature scale.

### 3.3.1 Specification of Fixed Points

Fixed points are temperatures chosen which are fixed and reproducible. They are useful as reference temperatures. Changes in the parameters from the fixed points are assigned numbers called degrees on a calibrated scale. Two such fixed points are:

- (i) The Lower fixed point (ice point): That is the temperature of equilibrium between ice, water and air saturated at standard pressure. This temperature is  $0^{\circ}\text{C}$ .
- (ii) The Upper fixed point (steam point): That is the temperature of steam rising from pure water boiling under standard atmospheric pressure. That is, the temperature of one standard atmosphere. This temperature is  $100^{\circ}\text{C}$ .
- (iii) The fundamental interval: This is the difference between the upper fixed point and the Lower fixed point divided into equal parts.

Other fixed points such as the sulphur point also exist for reference.

### 3.3.2 Factors for Changes in Fixed Points

1. Changes in the atmospheric pressure and latitude cause variation in freezing and boiling points. Changes caused by pressure in freezing point can be ignored. That due to impurities cannot be ignored.

2. Freezing point depression and Boiling point elevation are caused by impurities of slats. Hence water used in determining these points is required to be pure.
3. Daily floatation of barometric reading call for the correction of the boiling point. In the neighbourhood of standard atmospheric pressure, the boiling point rises by  $0.37^{\circ}\text{C}$  when the height of mercury barometer increases by 1.0 cm. Therefore true boiling point is given as on the Celsius scales as:

$$t^{\circ}\text{C} = 100^{\circ}\text{C} + 0.37 (B - 76)^{\circ}\text{C} \dots \dots \dots (1.1)$$

Where B is any atmospheric pressure in cm of mercury.

### SELF ASSESSMENT EXERCISE 2

Mention two factors that can change the fixed points on a temperature scale.

#### 3.3.3 The Temperature Scales

The systems of temperature scales are:

- (i) The Celsius scales whose ice point is  $0^{\circ}\text{C}$  and the steam point is at  $100^{\circ}\text{C}$ . Each part represents  $1^{\circ}\text{C}$ .
- (ii) The Fahrenheit scale whose ice point is  $32^{\circ}\text{F}$  while the steam point is  $212^{\circ}\text{F}$ . The fundamental interval is 180 divisions. Each division represents  $10^{\circ}\text{F}$ .
- (iii) The absolute scale of temperature, the thermodynamics scale. This will be discussed later.

#### 3.4 Specification of Interpolation

The way we establish the temperature of a body on either the Celsius scale or the Fahrenheit scale is what we refer to as the specification of interpolation. This therefore establishes the scale of temperature, which decides upon the temperature below, between and above the fixed points, are to be established.

We then choose a thermometric substance and its particular property, which will serve as a temperature indicator.

### 3.4.1 Definition of Temperature on Celsius Scale

If  $X$  represents the property of the thermometric substance, which serves as temperature indicator, by adopting the Celsius scale. Let  $X_0$  be the values of  $X$  of the thermometric substance when surrounds by the melting ice for a long time. Let  $X_{100}$  be the value of  $X$  when the substance has reached an equilibrium with steam at standard pressure (1 atmosphere).

Hence, the fundamental interval is defined as the change of  $X$  between the ice and steam points =  $X_{100} - X_0$ .

Consequently, the size of the Celsius degree, which results from our choice of property  $X$ , is defined at that range of temperature which causes a change in property which is  $Z$ .

$$\text{Hence } Z = \frac{X_{100} - X_0}{100} \dots\dots\dots (1.2)$$

If  $X_t$  is the value of  $X$  of the substance in the neighbourhood of another body whose temperature is to be determined then, the number of degrees by which the Celsius temperature  $t_c$  of the thermometric substance exceeds the temperature of melting ice  $0^\circ\text{C}$  is equal to the number of items the quantity  $Z$  is contained in  $(X_t - X_0)$ .

$$\therefore (t_c - 0^\circ\text{C}) \times Z = (X_t - X_0)^\circ\text{C} \dots\dots\dots (1.3)$$

But from Eq. 1.2, you know that

$$Z = \frac{X_{100} - X_0}{100}$$

Substituting Eq. (1.2) in Eq. (1.3), we get

$$\therefore (t_c - 0) \times \frac{X_{100} - X_0}{100} = (X_t - X_0)^\circ\text{C}$$

$$\therefore t_c = \frac{(X_t - X_0) \times 100^\circ\text{C}}{(X_{100} - X_0)} \dots\dots\dots (1.4)$$

### SELF ASSESSMENT EXERCISE 3

The lengths of the mercury column of a mercury thermometer are 1.06cm and 20.86cm respectively at the standard fixed points. What is the temperature of body, which produces 7.0cm of this mercury column?

### 3.4.2 Definition of Temperature on Fahrenheit Scale

In the case of the Fahrenheit scale, one can also state that

$$(t_F - 32) Z = (X_t - X_{32}) ^\circ F \dots\dots\dots (1.5)$$

$$\text{Where, } Z = \frac{(X_{212} - X_{32})}{(212 - 32)} ^\circ F$$

$$Z = \frac{X_{212} - X_{32}}{180} ^\circ F \dots\dots\dots (1.6)$$

Substituting Eq. (1.5) in Eq. (1.6), we get the expression

$$\therefore t_F - 32 = \left( \frac{X_t - X_{32}}{X_{212} - X_{32}} \right) X 180 ^\circ F$$

$$\therefore t_F = \left( \left( \frac{X_t - X_{32}}{X_{212} - X_{32}} \right) X 180 + 32 \right) ^\circ F \dots\dots\dots (1.7)$$

Furthermore, the value of the property of X at any definite temperature e is independent of the method of numbering temperature.

Hence  $X_{212} = X_{100}$  and  $X_{32} = X_0$

Now inserting these parameters in Eq. (1.7), we get

$$\therefore t_F = \left( \left( \frac{X_t - X_0}{X_{100} - X_0} \right) X 180 + 32 \right) ^\circ F \dots\dots\dots (1.8)$$

Also from Eq. (1.4), we get

$$\frac{t_c}{100} = \frac{X_t - X_0}{X_{100} - X_0} \dots\dots\dots (1.9)$$

Therefore, a relation between  $t_F$  and  $t_c$  can be obtained as

$$t_F = \left( \frac{t_c}{100} X 180 + 32 \right) ^\circ F$$

$$\therefore t_F = \left( \frac{9}{5} t_c + 32 \right) ^\circ F$$

The Eq. (1.10) enables us to convert a temperature measurement from one scale to the other.

**SELF ASSESSMENT EXERCISE 4**

Covert 50°F to Celsius scale.

Now, let us discuss the examples of X property for different thermometers with Celsius scale.

- (a) Platinum thermometer

X is in terms of resistance (R), thus

$$t = \frac{R_t - R_o}{R_{100} - R_o} \times 100^\circ \text{C} \dots\dots\dots (1.11)$$

- (b) Mercury thermometer

X is in terms of length of mercury L.

$$t = \frac{L_t - L_o}{L_{100} - L_o} \times 100^\circ \text{C} \dots\dots\dots (1.12)$$

- (c) Constant Volume thermometer

X is in terms of the pressure P of the gas at constant volume

$$t = \frac{P_t - P_o}{P_{100} - P_o} \times 100^\circ \text{C} \dots\dots\dots (1.13)$$

- (d) Constant Pressure thermometer

X is in terms of the volume of the gas at constant pressure

$$t = \frac{V_t - V_o}{V_{100} - V_o} \times 100^\circ \text{C} \dots\dots\dots (1.14)$$

**SELF ASSESSMENT EXERCISE 5**

A platinum resistance thermometer has a resistance of 10.40 ohms at 0°C and 14.35 ohms at 100°C. Assuming that the resistance changes uniformly with temperature, what is

- (a) The temperature when the resistance is 11.19 ohms?

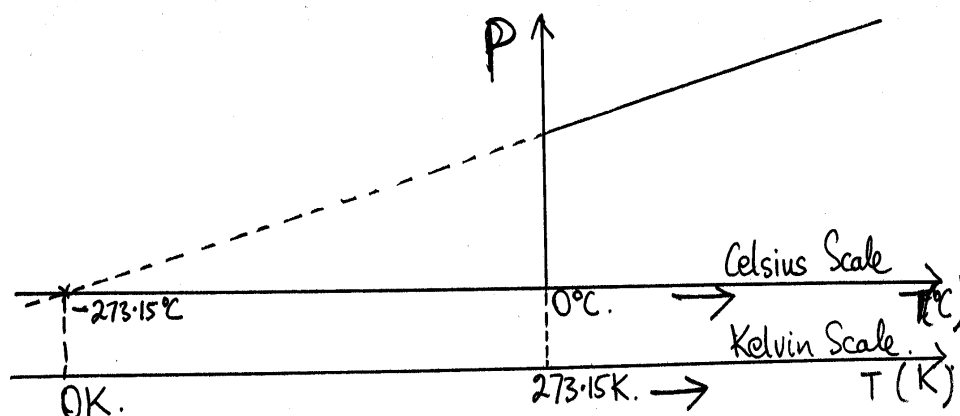
- (b) The resistance of the thermometer when the temperature is  $45^{\circ}\text{C}$ ?

### 3.5 Thermodynamic Scale (Absolute Scale) of Temperature

The thermodynamic scale is the standard temperature scale used in scientific measurements. The symbol on this scale is T and it is measured in Kelvin after Lord Kelvin.

On the thermodynamic scale, the reference point is the triple point of water where saturated water vapour, pure water and melting ice are in equilibrium to each other. The temperature of the triple point of water has been found to be  $273.16\text{K}$ . The ice point is  $273.15\text{K}$ . The slight difference with the triple point is due to the pressure in the two cases.

There is variation of Pressure (P) with temperature T is shown in fig. 3.9. When the graph is extrapolated, it meets the temperature axis at  $-273.15^{\circ}\text{C}$ . This value of temperature is called absolute zero (OK) by Kelvin. It is to be noted that the value of pressure at this temperature reduces to zero.



**Fig. 3.9**

On the Celsius temperature scale,

$$\begin{aligned} -273.15^{\circ}\text{C} &= 0 \\ 0^{\circ}\text{C} &= 273.15\text{K} \end{aligned}$$

Hence the change in  $1^{\circ}\text{C}$  on the Celsius scale is equal to the change of  $1\text{K}$  on the Kelvin (Thermodynamics) scale.

### 4.0 CONCLUSION

What you have learnt in this unit concerns the concept of temperature and how it is measured. The property of a substance which varies with temperature is used to measure the temperature of a body through an appropriate scale. You have learnt about the Celsius, Fahrenheit and the



Absolute scale. The property of a substance is used in the construction of a thermometer.

## 5.0 SUMMARY

In this unit, you have learnt:

- the difference between temperature and heat;
- the concept of temperature using the sensation of human feelings which is always sensitive;
- how the zeroth law is used to conceptualize the concept of temperature objectively by using some measurable properties such as length of a liquid, pressure on a gas at constant volume, resistance and the electromotive force;
- the scales of temperature measurements;
- that on the thermodynamics scale the triple point of water is chosen as the fixed point and is defined as 273.16K.

### ANSWER TO SELF ASSESSMENT EXERCISE 1

- Heat is a form of energy while temperature is the degree of hotness or coldness in a body.
- Heat flows from higher temperature to a lower temperature. Thus the difference in temperature dictates the direction of transfer of the heat energy.

### ANSWER TO SELF ASSESSMENT EXERCISE 2

See the text.

### ANSWER TO SELF ASSESSMENT EXERCISE 3

Using the Eq. (1.4) as

$$t_c = \frac{(X_t - X_o) \times 100^\circ\text{C}}{(X_{100} - X_o)}$$

Where,  $X_t = 7.00\text{cm}$ ,  $X_{100} = 20.86\text{cm}$ ,  $X_o = 1.06\text{cm}$

Substituting this parameter in the Eq. (1.4) we get

$$\therefore t_c = \left( \frac{7.00\text{cm} - 1.06\text{cm}}{20.86\text{cm} - 1.06\text{cm}} \right) \times 100^\circ\text{C}$$

$$= \frac{5.94\text{cm}}{19.80\text{cm}} \times 100^\circ\text{C}$$

$$t_c = 30^\circ\text{C}$$

#### ANSWER TO SELF- ASSESSMENT EXERCISE 4

Using Eq. (1.10) as

$$t_F = \left( \frac{9}{5}t_c + 32 \right)^\circ\text{F}$$

Substitute  $t_F = 50^\circ\text{F}$

$$\therefore 50^\circ\text{F} = \left( \frac{9}{5}t_c + 32 \right)^\circ\text{F}$$

On rearranging the terms, we get

$$\therefore 50^\circ\text{F} = \frac{9}{5}t_c + 32$$

$$18 = \frac{9}{5}t_c$$

$$\therefore t_c = \frac{18 \times 5}{9} \text{ C} = 10^\circ\text{C}$$

#### ANSWER TO SELF ASSESSMENT EXERCISE 5

Use Eq. (1.11) as

$$(a) \quad t = \frac{R_t - R_o}{R_{100} - R_o} \times 100^\circ\text{C}$$

Substitute  $R_t = 11.19 \text{ ohms}$ ,  $R_{100} = 14.35 \text{ ohms}$

$$R_o = 10.40 \text{ ohms}$$

$$\therefore t = \frac{11.19\Omega - 10.40\Omega}{14.35\Omega - 10.40\Omega} \times 100^\circ\text{C}$$

$$t = \frac{0.79\text{ohms}}{3.95\text{ohms}} \times 100^\circ\text{C}$$

$$= 20^\circ\text{C}$$

(b) Again use Eq. (1.11)

$$t = \frac{R_t - R_o}{R_{100} - R_o} \times 100^\circ \text{C}$$

Substituting  $t = 45^\circ \text{C}$ ,  $R_o$  and  $R_{100}$  take their usual values

On arranging the terms, we will get,

$$\therefore 45^\circ \text{C} = \frac{R_t - 10.40\Omega}{14.35\Omega - 10.40\Omega} \times 100^\circ \text{C}$$

$$\therefore 45^\circ \text{C} = \frac{R_t - 10.40\Omega}{3.9\Omega} \times 100^\circ \text{C}$$

$$\therefore \frac{45}{100} \times 3.9\Omega = R_t - 10.40\Omega$$

$$\therefore 1.7775\Omega = R_t - 10.40\Omega$$

$$\therefore R_t = (1.7775 + 10.4)\Omega$$

$$R_t = 12.18\Omega$$

## 6.0 TUTOR-MARKED ASSIGNMENT

1. At what temperature do the Fahrenheit and the Celsius scales coincide?
2. The normal boiling point of liquid oxygen is  $-182.97^\circ \text{C}$ , what is this temperature on the Kelvin and Fahrenheit scales?
3. What is the body temperature of a normal human being on the Celsius scale? What will this value be on the Fahrenheit scale?
4. An ungraduated mercury thermometer attached to a millimeter scale reads 22.8mm in ice and 242mm in steam at standard pressure. What will the millimeter read when the temperature is  $20^\circ \text{C}$ ?

## 7.0 REFERENCES/FURTHER READINGS

- Awe, O. and Okunola, O. O. (1986). *Comprehensive Certificate Physics*, University Press.
- Ference, M. (Jnr.), Lemon, H.B. and Stephenson, R. J. (1970). *Analytical Experimental Physics*, the University of Chicago Press.
- Feynman, R. P., Leighton, R. B. and Sands, M. (1971). *The Feynman Lectures on Physics*, Addison – Wesley Publishing Company, California.
- Flowers, B. H. and Mendoza, E. (1970). *Properties of Matter*, London: John Wiley and Sons Limited.
- Noaks, M. A. (1963). *New Intermediate Physics*, Macmillan and company Limited.
- Soars, F. W., Zemansky, M.W. and Young, H. D. (1980). *College Physics*, London: Addison – Wesley Publishing Company.
- Tyler, F. (1966). *Heat and Thermodynamics*, London: Edward Arnold Publisher Limited.
- Wilkinson, J. (1983). *Essentials of Physics*, Australia: McMillan Education.
- Zemansky, M. W., (1968). *Heat and Thermodynamics*, New York: McGraw Hill.

## UNIT 2 TYPES OF THERMOMETERS

### CONTENTS

- 1.0 Introduction
- 2.0 Objectives
- 3.0 Main Content
  - 3.1 Thermometric Properties
  - 3.2 Types of Thermometer
    - 3.2.1 Liquid-in-Glass Thermometers
      - 3.2.1.1 The Clinical Thermometers
      - 3.2.1.2 The Maximum and Minimum Six's Thermometers
    - 3.2.2 Constant Volume Gas Thermometers
    - 3.2.3 Platinum Resistance Thermometers
    - 3.2.4 Thermo-Electric Thermometers
- 4.0 Conclusion
- 5.0 Summary
- 6.0 Tutor-Marked Assignment
- 7.0 References/Further Readings

### 1.0 INTRODUCTION

In Unit 1, you learnt about the difference between temperature and heat. You also learnt about the concept of temperature by defining it qualitatively and quantitatively. The zeroth law was used to define temperature objectively and quantitatively. This was done by the use of measurable property of a substance that varies linearly or uniformly with changes in temperature.

In this unit, we shall go further by considering the thermometric properties of various substances used in the construction of thermometers. Finally, we shall describe some types of thermometers.

### 2.0 OBJECTIVES

At the end of this unit, you should be able to:

- state the conditions necessary for the choice of properties and the substance used for temperature measurement
- list the different types of thermometers and their thermometric properties
- show the appropriate use of thermometers in life.

### 3.0 MAIN CONTENT

#### 3.1 Thermometric Properties

In the last unit, we discussed about the temperature scale. You learnt that to establish such a scale, there is a requirement of some physical properties of a substance and the fixed point.

*But, suppose you are asked to construct a thermometer which they may be used to measure the temperature of a body, what are the things you must consider in the choice of the property of the substance to be used?*

The following are some necessary conditions governing the choice of properties and materials for temperature measurement by a thermometer.

- The substance must have a considerable variation over a small increase in temperature. That means, it must be very sensitive to a small change of temperature.
- The change in the property of the substance must occur readily.
- The range of temperature over which the thermometer can be used should be as large as possible.
- The thermometric substance should have a small thermal capacity. This means that it must readily acquire the temperature of its surrounding.
- The time taken to acquire this temperature should be small. This will minimize time lag when it is used and when variation of temperature should follow.

#### SELF ASSESSMENT EXERCISE 1

Enumerate five thermometric properties that must be taken into consideration before choosing a substance to be used to measure the temperature of a body.

Notice, as we proceed further how these properties are used in the construction of thermometers that will now be discussed.

#### 3.2 Types of Thermometer

Thermometers may be classified according to the thermometric properties used in constructing such thermometers. For example, we have:

- **Liquid-in-Glass Thermometers:** Such thermometers use the expansion of the liquid in the glass tube. As the liquid volume

increases with temperature rise, the length of the liquid along the tube varies with temperature.

- **Constant Volume-Gas Thermometer:** Which makes use of a given mass of gas whose pressure varies with temperature at constant volume.
- **Resistance Thermometer:** Makes use of the variation of resistance of a given conductor such as platinum with temperature.
- **Thermo-electric Thermometer:** Which makes use of the variation of electromotive force (emf) developed between the pair of junctions of two dissimilar metals with temperature.

We shall now discuss each one of them in details.

### 3.2.1 Liquid-in-Glass Thermometers

The liquid-in-glass thermometer makes use of two liquids such as alcohol or mercury. The mercury-in glass thermometers are commonly used in the laboratory or in the hospitals as clinical thermometers. Whereas, the alcohol-in-glass thermometers are used in temperate countries because alcohol has a much lower melting point than mercury. (See table 3.1).

**Table 3.1 Properties of Mercury and Alcohol as Thermometric Liquids**

	<b>Mercury</b>		<b>Alcohol</b>
1	Mercury solidifies at $-39^{\circ}\text{C}$	1	Alcohol solidifies at
Hence alcohol may be used for much lower temperature than mercury's.			
2	Mercury boils at $357^{\circ}\text{C}$	2	Alcohol boils at $78^{\circ}\text{C}$
Thus, alcohol is not suitable for temperatures above $50^{\circ}\text{C}$ or $60^{\circ}\text{C}$ whereas mercury could be used to measure temperatures well above $500^{\circ}\text{C}$ even as high as $800^{\circ}\text{C}$ provided the space above the mercury is filled with Nitrogen or some inert gases which increases its boiling point.			
3	Mercury does not wet glass. It is able to move with jerky action.	3	Alcohol wets glass. The thread of alcohol has therefore the tendency to stick to the stem.
4	Mercury expands less than alcohol for a given rise in temperature.	4	Alcohol expands more than mercury for a given rise in temperature.

Alcohol thermometers are more sensitive than mercury.			
5	Mercury is opaque. Silvery in colour it is therefore easily seen.	5	Alcohol is transparent. It has to be coloured before it can be seen.
6	A good conductor of heat	6	A poor conductor of heat.
7	It has low specific heat capacity.	7	Has high specific heat capacity.

From the above table it will be observed that in certain areas alcohol has some advantages over mercury while in some areas mercury also has some advantages over alcohol.

**SELF ASSESSMENT EXERCISE 2**

State the advantages and disadvantages of the use of alcohol over mercury as thermometric liquids.

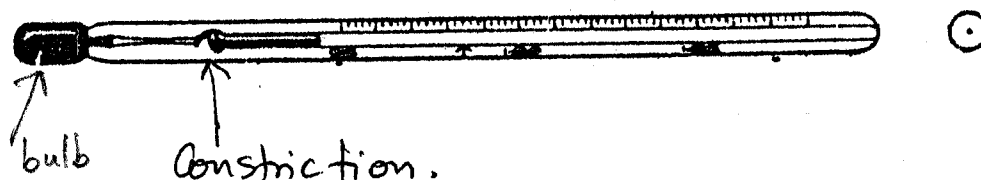
The increase in length (L) of the mercury-in-glass thermometer is used as a property as the temperature increases. Using the Celsius scale therefore, the temperature t is defined as:

$$t = \left( \frac{L_t - L_o}{L_{100} - L_o} \right) \times 100^\circ C \dots\dots\dots(2.1)$$

where,  $L_t$  = length of the mercury column at  $t^\circ C$   
 $L_{100}$  = length of the mercury at  $100^\circ C$   
 $L_o$  = length of the mercury at  $0^\circ C$

**3.2.1.1 The Clinical Thermometers**

The clinical thermometer is usually used in the hospital clinics, hence, the name. It is specifically adapted for measuring the temperature of the human body. The stem of the clinical thermometer is graduated from  $35^\circ C$  to  $45^\circ C$ .



**Fig. 3.1 The Clinical Thermometer**

It has a constriction in the stem near the bulb, which prevents the mercury from entering the bulb. Thus the measurement can be read at

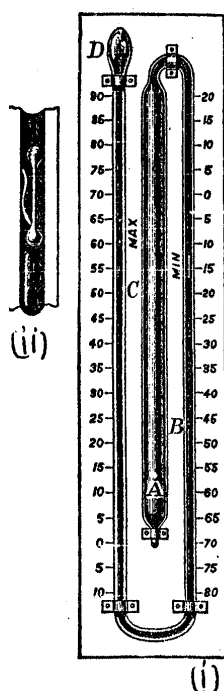


leisure. Jerking the instrument in order to drive the mercury back then returns the broken thread of the mercury.

The laboratory thermometers are longer than the clinical thermometers and they have no constrictions in them. Besides, they are usually longer with longer range of temperatures from  $-10^{\circ}\text{C}$  to about  $150^{\circ}\text{C}$ .

### 3.2.1.2 The Maximum and Minimum Six's Thermometers

Apart from the laboratory and the clinical thermometers, there is yet another mercury-in-glass thermometer called the Maximum and Minimum (six's) thermometer.



**Fig. 3.2: Maximum and Minimum (Six's) Thermometer**

The Six's thermometer is used to measure the maximum and minimum temperatures on a particular day (fig. 3.2).

The thermometer is made up of long bulb A that contains alcohol or any other suitable liquid. BC is a thread of mercury. Above C, there is more alcohol which partly fills the bulb D. Above the surface of the mercury thread at B and C are light steel indices (fig 3.2) with a spring attached to each steel to prevent it from slipping.

When the alcohol in A expands, the mercury thread in BC is pushed round sending the index at C upwards and leaving the index B in position. When the alcohol in A contracts, the mercury thread BC is drawn back leaving the C index to record the maximum temperature reached. The index B similarly records the minimum temperature

reached. A magnet is used to reset each index by drawing them down to the surface of the mercury thread.

The Minimum and Maximum thermometer is therefore used to record the minimum and maximum temperatures of the day. The knowledge of such temperatures over a period of time may be useful in predicting the weather.

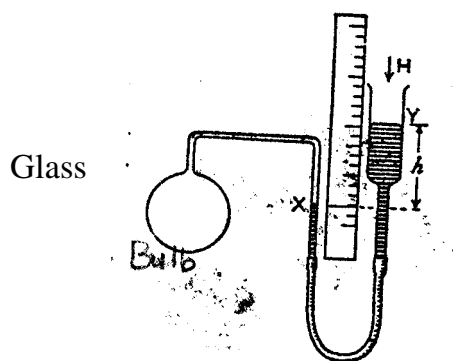
### 3.2.2 Constant Volume Gas Thermometers

The two properties that are kept constant in the construction of this thermometer are the volume (V) and the amount of the gas in moles (n). Thus the varying properties are the pressure (P) on the gas and the temperature (t).

Consider a fixed mass of gas maintained at constant volume in a vessel capable of measuring the pressure P. If  $P_0$  and  $P_{100}$  are the pressures at ice and steam points respectively and  $P_t$  is the pressure at some unknown temperature  $t^\circ\text{C}$ . Assuming that equal changes in pressure denote equal changes in temperature, then

$$\frac{P_t - P_0}{P_{100} - P_0} \times 100^\circ\text{C} \dots\dots\dots (2.2)$$

Jolly’s Constant volume air thermometer will be described to show how the pressures are measured at constant volume but at varying temperatures (fig.3.3).



**Fig. 3.3 Constant Volume Air Thermometer**

It consists of a glass bulb of about  $100\text{cm}^3$  in volume containing dry air. This bulb is connected to a fine glass capillary tube and a rubber pressure tube, which in turn is connected to a moveable reservoir of mercury.

There is mark X on the capillary tube. This is the constant volume mark. The total pressure on the air is (H + h) where H is the atmosphere pressure and h is the height of the mercury above the mark X.

$$\text{If } P_0 = H + h_0$$

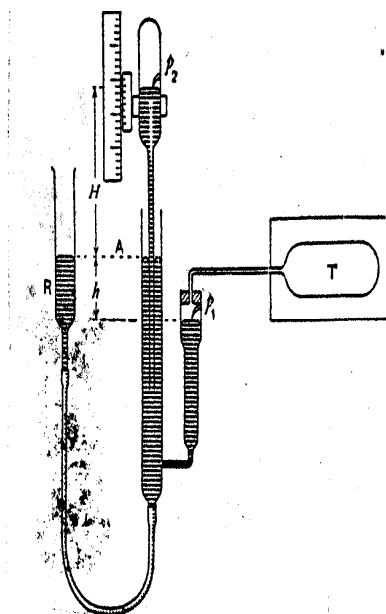
$$P_{100} = H + h_{100} \text{ and}$$

$$P_t = H + h_t$$

$$\text{Then } t = \left( \frac{P_t - P_0}{P_{100} - P_0} \right) \times 100^\circ C$$

$$t = \left( \frac{h_t - h_0}{h_{100} - h_0} \right) \times 100^\circ C \dots\dots\dots (2.3)$$

The Jolly's constant-volume gas thermometer is not very convenient to use, when compared with the mercury-in-glass, resistance and thermo-electric thermometers.



**Fig. 3.4: Standard Constant-Volume Hydrogen Thermometer**

Fig. 3.4 is a standard constant-volume hydrogen thermometer as developed by Chappius. It consists of Platinum Iridium cylinder T which is connected to a manometer. The constant volume is achieved through the devise P<sub>1</sub>. A barometer is also incorporated with the manometer using a device P<sub>2</sub>. The vertical distance between P<sub>1</sub> and P<sub>2</sub> gives the total pressure.

The Chappius version is an improvement of Jolly's simple gas thermometer. It is to overcome the inaccuracies in Jolly's instrument due to fluctuations in the barometric heights in the course of the experiment. It is also to reduce errors due to capillary depression on the mercury which come to play when using tubes of narrow bore in Jolly's instrument.

### 3.2.3 Platinum Resistance Thermometers

As the name of the thermometer suggests, it is a thermometer that depends on the resistance of a wire whose values change with temperature.

Callendar found out that the resistance of pure metals increases as the temperature increases. He showed that the resistance of pure platinum varies with the gas thermometer temperature  $t$  according to the equation.

$$R_t = R_0 (1 + A_t + B_t^2) \dots\dots\dots (2.4)$$

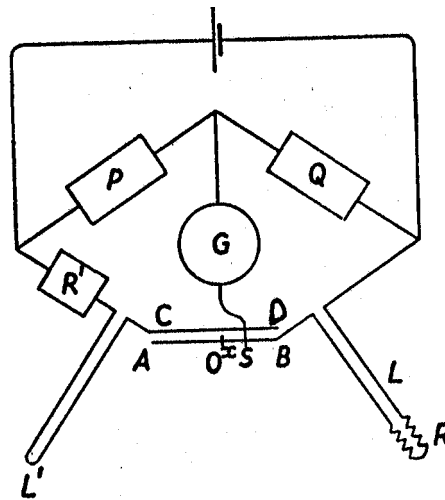
Where,  $R_t$  and  $R_0$  are the resistances at  $t^\circ\text{C}$  and  $0^\circ\text{C}$  respectively.  $A$  and  $B$  are some constants for a given specimen.

On the platinum resistance scale of temperature, equal changes in resistance denote equal changes in temperature.



**Fig. 3.5 Platinum Resistance**

Fig. 3.5 shows a typical platinum resistance which is used in connection with the Wheatstone (Meter) Bridge devised by Callendar and Griffiths (Fig. 2.6). The bridge is used to obtain a balance point which enables the experiment to determine the various values of  $R_t$ ,  $R_{100}$  and  $R_0$



**Fig. 2.6 Callendar and Griffiths Wheatstone Bridge**

Let  $R_0$  and  $R_{100}$  be the resistances of ice and steam respectively and  $R_t$  the resistance of the platinum at  $t_p$ °C.

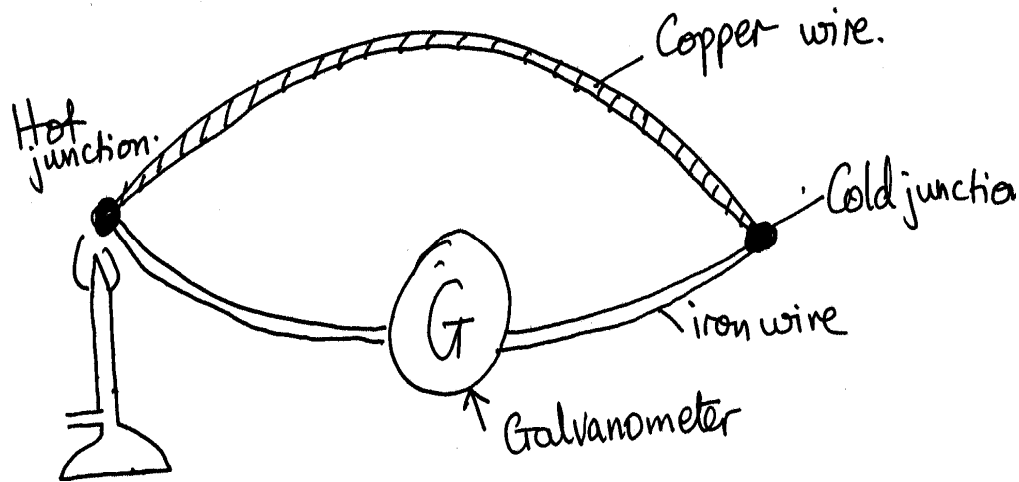
$$T_p = \frac{R_t - R_0}{R_{100} - R_0} \times 100^\circ\text{C} \dots\dots\dots (2.5)$$

The platinum resistance thermometer has a wide range noted for its extreme accuracy over the length of this range. However, its chief disadvantage is the long time needed for it to assume the temperature of its surroundings and the time required for making an observation so that it cannot follow rapidly changing temperatures. This is where the thermo-electric thermometer is a good substitute.

**3.2.4 Thermo-Electric Thermometers**

The thermo-electric thermometer is otherwise called thermo-couple. This type of thermometer is constructed by using the Seebeck effect. First, we will discuss about the Seebeck effect.

Seebeck effect simply states that if two dissimilar metals, such as copper and iron are joined to make a complete circuit, then on heating one end of the junctions, a current flows round the circuit.



**Fig. 3.7: Thermo-Electric Couple**

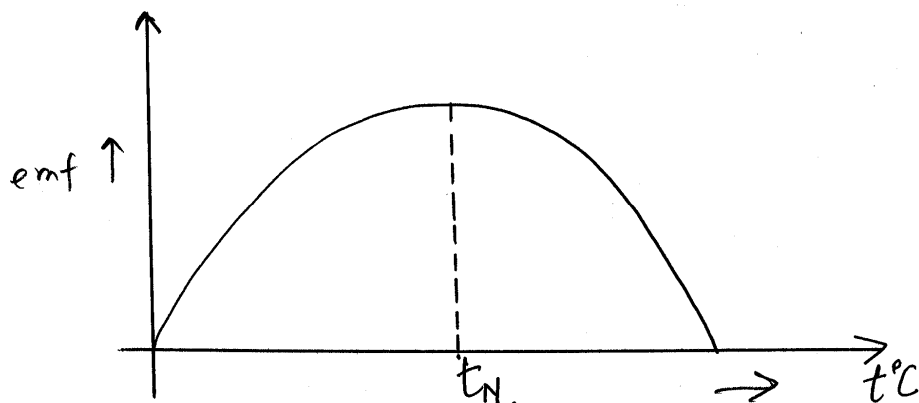
The presence of the galvanometer is to detect and measure the magnitude of the current that flows in the circuit.

This type of arrangement is called a thermo-couple. The emf established round the circuits depends on the nature of the metals used to form the couple and also on the temperature difference between the hot and cold junctions.

The cold junction is usually maintained at ice point. It has been shown experimentally that when the other junction is at some temperature  $t$ , the thermo-electric emf set up depends on the temperature accordingly as

$$E = A + Bt + Ct^2 \dots\dots\dots (2.6)$$

Where  $A$ ,  $B$  and  $C$  are constants depending on the metals used. The graph between emf versus  $t$  is shown in fig. 3.8.



**Fig. 3.8: emf against t**

The temperature where the emf is maximum for the two metals is called the neutral temperature  $t_N$ .

It is however more convenient to observe the thermo-electric behaviour of the two metals graphically by plotting their thermo-electric power (P) against temperature.

Thermo-electric power is the change in the thermo-electric emf per degree Celsius in temperature between the hot and cold junctions.

From the Eq. (2.6) if t is measure from the ice point, then A is equal to zero. Then,

$$\therefore E = Bt + Ct^2 \dots\dots\dots (2.7)$$

The graph of E versus t is either fig. 3.9 (i) or fig. 3.9 (ii) as shown below.

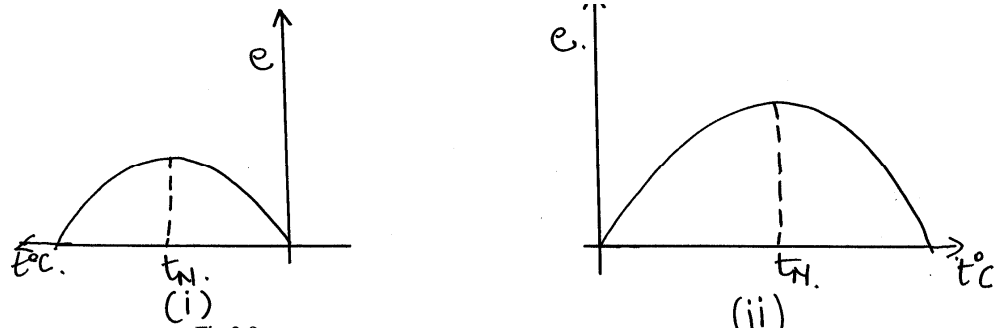


Fig. 3.9

But Power (P) is given by

$$\frac{de}{dt} = B + 2Ct \dots\dots\dots (2.8)$$

Thus the plot of  $\frac{de}{dt}$  of versus t is either given by fig. 3.10 (i) or fig. 3.10 (ii)

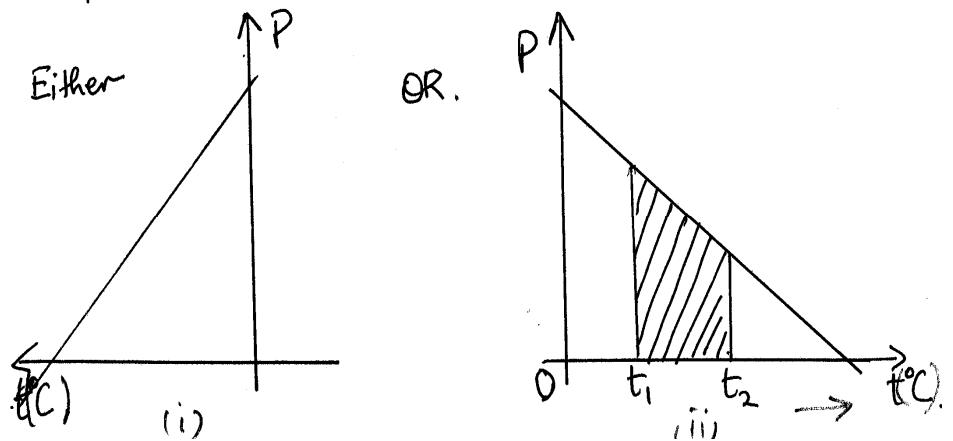


Fig. 3.10

Since we are increasing the temperature from zero to higher temperature fig 3.10 (ii) will be a better choice.

The intercept on the  $t$  – axis indicates where  $\frac{de}{dt} = 0$  and that is the neutral temperature. It is possible to establish from this graph the emf when the junctions are kept at temperatures  $t_1$  and  $t_2$ . It is equal to the area under the curve between  $t_1$  and  $t_2$ .

$$E = \int_{t_1}^{t_2} P dt \dots\dots\dots (2.9)$$

In theory, it is more satisfactory to measure the electromotive force (emf) developed instead of the current. This is because the emf depends on the total resistance of the circuit which alters as the temperatures changes. In the industrial set up, a high resistance millivoltmeter is used. The thermo-electric couple is capable of measuring up to 1500°C.

#### 4.0 CONCLUSION

You have learnt in this unit the different types of thermometers used in measuring temperatures. A thermometer uses the property of a substance which varies uniformly with changes in temperature. It is this thermometric property that is used in the construction of thermometers. Each thermometer has its own range of measurement.

#### 5.0 SUMMARY

In this unit, you have learnt the following:

- Thermometers are constructed using a specified physical property known as thermometric property.
- Such thermometric properties are volume of a liquid, pressure of a gas at constant volume, resistance of a metal and the electromotive force of a thermocouple which vary with temperature.
- There are different types of thermometers. Each type is grouped according to the kind of thermometric property used in its construction. There are:
  - (i) Liquid-in-glass thermometers
  - (ii) Resistance thermometers
  - (iii) Thermo-electric thermometer
- The merits and demerits of each type have been discussed.



**ANSWER TO SELF ASSESSMENT EXERCISE 1**

Refer to section 3.1 of the text.

**ANSWER TO SELF ASSESSMENT EXERCISE 2**

Refer to section 3.2.1 for solution.

**6.0 TUTOR-MARKED ASSIGNMENT**

1. State the five conditions necessary for the choice of properties and the substance used for temperature measurement.
2. Mention the types of thermometers that exist and their appropriate thermometric properties used for their construction.
3. A body has temperature of about  $1200^{\circ}\text{C}$ . Which thermometer would you use and why?

**7.0 REFERENCES/FURTHER READINGS**

Awe, O. and Okunola, O. O. (1986). *Comprehensive Certificate Physics*, Ibadan: University Press Limited.

Ference, M. (Jnr.), Lemon, H.B. and Stephenson, R. J. (1970). *Analytical Experimental Physics*, Chicago: the University of Chicago Press.

Feynman, R. P., Leighton, R. B. and Sands, M. (1971). *The Feynman Lectures on Physics*, Addison – Wesley Publishing Company, California.

Flowers, B. H. and Mendoza, E. (1970). *Properties of Matter*, London: John Wiley and Sons Limited.

Noaks, M. A. (1963). *New Intermediate Physics*, Canada: Macmillan and company Limited.

Soars, F. W., Zemansky, M.W. and Young, H. D. (1980). *College Physics* London: Addison – Wesley Publishing Company.

Tyler, F.(1966). *Heat and Thermodynamics*, London: Edward Arnold Publisher Limited.

Wilkinson, J. (1983). *Essentials of Physics*, Australia: McMillan Education Limited.

Zemansky, M. W., (1968). *Heat and Thermodynamics*, New York: McGraw Hill.

## UNIT 3 HEAT MEASUREMENT

### CONTENTS

- 1.0 Introduction
- 2.0 Objectives
- 3.0 Main Content
  - 3.1 Concept of Heat
  - 3.2 Heat Capacity
  - 3.3 Specific Heat Capacity
    - 3.3.1 Simple Method of Mixtures
    - 3.3.2 Inclusion of Calorimeter in Method of Mixtures
  - 3.4 Latent Heat
  - 3.5 Explanation of Latent Heat
    - 3.5.1 Specific Latent Heat of Fusion
    - 3.5.2 Specific Latent Heat of Vapourization
    - 3.5.3 Latent Heat and Internal Energy
- 4.0 Conclusion
- 5.0 Summary
- 6.0 Tutor-Marked Assignment
- 7.0 References/Further Readings

### 1.0 INTRODUCTION

Heat and temperature are not the same but they are closely related. Heat, as you must have learnt is a form of energy while temperature is the degree of coldness or hotness of a body, may the body be solid, liquid or gas. This degree of coldness or hotness is measured objectively and quantitatively by using the thermometer. *The question arises is: “how would you measure heat energy?”* The study of heat measurement is known as Calorimetry in physics.

The nature of substance plays an important role in the study of thermal phenomena. For example, a large iron tank and an aluminum kettle have a different heat capacity. It depends on their respective masses and on the metal used.

In this unit you will be introduced to the measurement of heat. The nature of substance plays an important role in the study of thermal phenomena. For example, a large iron tank and an aluminum kettle have a different heat capacity. It depends on their respective masses and on the metal used. Some of the major concepts crucial to the measurement of heat are: heat capacity, specific heat capacity, specific latent heat of fusion and vapourization which you will also study here. You will also learn about how temperature measurement is related to the measurement of heat energy.

## 2.0 OBJECTIVES

At the end of this unit, you should be able to:

- explain the concept of heat
- define the heat (thermal) capacity of a substance
- define specific heat capacity of a substance
- define (a) the specific latent heat of fusion (b) specific latent heat of vapourization
- solve problems involving the concepts mentioned above.

## 3.0 MAIN CONTENT

### 3.1 Concept of Heat

Prescot Joule first showed that heat is a form of energy in an experiment in which mechanical work (energy) was transformed into heat. Other scientists also showed that heat from fuel, such as gasoline in an engine, may be transformed to mechanical energy when the engine is used to drive carts, trains and aeroplanes. In an electric power station, heat from fuel is changed to electrical energy.

The unit of energy is Joule (J) which is also the unit of measuring mechanical energy and electrical energy. We also have larger units such as kilojoule (KJ) and megajoule (MJ).

Power, you will remember, is the rate of doing work. It is also defined as the rate at which heat energy is given out by a source. For example, the heat energy delivered per second by a gas burner is its power. This power is measured in watts (W). One watt is therefore defined as one joule per second ( $\text{J/s}$  or  $\text{Js}^{-1}$ ). Other larger units are kilowatt (KW) and megawatt (MW).

Sources of heat energy are the sun, fuels such as coal, gas, oil and electricity.

Can you think of other sources of heat energy?

### 3.2 Heat Capacity

You would have observed that a source of heat will transfer its heat energy to another body. The source is usually at a high temperature while the other body being heated is at a lower temperature. When the source and the other body are in contact, the rise in temperature takes place in colder body.

Let  $t_1^{\circ}\text{C}$  be the initial temperature of the body and  $t_2^{\circ}\text{C}$  be the final temperature when  $Q$  joules of heat has been supplied.

Then the change in temperature,

$$\Delta\theta = (t_2 - t_1)^{\circ}\text{C}$$

The amount of heat in joules that is capable of changing its temperature through  $1^{\circ}\text{C}$  is  $\frac{Q}{\Delta\theta}$

This amount of heat to change the temperature of the body is described as the heat capacity of the body. It is usually represented by the symbol  $H$ .

**By definition, the heat (thermal) capacity ( $H$ ) of a body, is the quantity heat ( $Q$ ) in joules required to change its temperature by one degree (Celsius or one Kelvin).**

$$\therefore H = \frac{Q}{\Delta\theta^{\circ}\text{C}}$$

Where,  $\Delta\theta = (t_2 - t_1)$

$$\therefore H = \frac{Q}{(t_2 - t_1)^{\circ}\text{C}} \dots\dots\dots (3.1)$$

Thus the unit of heat (thermal capacity) is expressed in joules per Celsius or joules per Kelvin ( $\text{JK}^{-1}$  or  $\text{J}^{\circ}\text{C}^{-1}$ ).

The values of  $H$  for different bodies are not the same. They vary from one body to another.

### EXAMPLE 3.1

A metal container of heat capacity  $200\text{J}^{\circ}\text{C}^{-1}$  is heated from  $15^{\circ}\text{C}$  to  $45^{\circ}\text{C}$ . What is the total quantity of heat required to do so?

### SOLUTION 3.1

Using Eq. (3.1)

$$H = \frac{Q}{\Delta\theta}$$

$$\begin{aligned}\therefore Q &= H\Delta\theta \\ &= H(t_2 - t_1)\end{aligned}$$

Substituting the values, we get

$$\begin{aligned}&= 200 \text{ J/}^\circ\text{C} \times (45 - 15)^\circ\text{C} \\ &= 200 \times 30\text{J} \\ Q &= 6000\text{J} \\ Q &= 6\text{KJ}\end{aligned}$$

### 3.3 Specific Heat Capacity

If there are different masses of a substance  $m_1$ ,  $m_2$  and  $m_3$ , it will be observed that to raise their temperatures through  $1^\circ\text{C}$  each, they will require different quantities of heat energy  $Q_1$ ,  $Q_2$  and  $Q_3$ .

Experiments have shown that the quantities of heat ( $Q$ ) required to change their temperature through  $1^\circ\text{C}$  is proportional to the corresponding masses ( $m$ ).

$$\therefore Q \propto m \dots\dots\dots (3.2)$$

However, if we fix the mass of the substance to 1kg and we transfer various quantities of heat  $Q$  to it, there will be various corresponding changes in temperature  $\Delta\theta$ . Again, it will be found that the quantities of heat  $Q$  to change the temperature of 1kg mass of the body will be proportional to the corresponding changes in temperature  $\Delta\theta$ . Hence we can write

$$Q \propto \Delta\theta \dots\dots\dots (3.3)$$

Combining these two factors, we get

$$\begin{aligned}Q &\propto m\Delta\theta \\ \text{Or } Q &= Cm\Delta\theta \dots\dots\dots (3.4)\end{aligned}$$

Where  $C$  is a constant of proportionality known as the specific heat capacity of the substance

$$\therefore C = \frac{Q}{m\Delta\theta}$$

**The specific heat capacity of a substance is therefore defined as the amount of heat  $Q$  (in joules) required to raise the temperature of 1kg mass of substance through unit degree ( $1^\circ\text{C}$  or  $1^\circ\text{K}$ ).**

The unit of  $C$  is  $\text{J/kg}^\circ\text{C}$  or  $\text{Jkg}^{-1}\text{C}^{-1}$  or  $\text{Jkg}^{-1}\text{K}^{-1}$ . It can also be measured in  $\text{cal. g}^{-1} \text{K}^{-1}$

The value of  $C$  differs from one substance to another.

The values of specific heat capacity for some common substances are given in Table 3.1 below.

**Table 3.1: Specific Heat Capacity for Some Substances**

Substance	Specific heat capacity in $\text{Jkg}^{-1}\text{C}^{-1}$
Iron	460
Copper	400
Lead	120
Aluminum	800
Water	4200

### EXAMPLE 3.2

How much heat is needed to bring 10g of water from  $50^\circ\text{C}$  to boiling point? (Specific heat capacity of water =  $4200 \text{ Jkg}^{-1}\text{C}^{-1}$ )?

### SOLUTION 3.2

$$\begin{aligned} \text{Using Eq. 3.4} \quad Q &= mC\Delta\theta \\ &= mC(t_2 - t_1) \end{aligned}$$

Substituting the values, in the Eq. 3.4 we get,

$$= 10\text{g}/1000\text{kg} \times 4200\text{J/kg}^\circ\text{C} \times (100 - 50)^\circ\text{C}$$

$$\begin{aligned} Q &= 2100\text{J} \\ &= 2.1\text{KJ} \end{aligned}$$

### 3.3.1 Simple Method of Mixtures

In this section we shall consider exchange of heat between two bodies in such a way that one body is at a high temperature and the other is at a low temperature. In the simple method of mixtures, we are simply looking at hot and cold substances being mixed without considering the container in which they are being mixed. The principle of conservation of heat energy is being observed very closely. **Here, very briefly, we will discuss the principle of conservation of heat energy.**

This principle states that *“the heat lost by a hot body is equal to the heat gained by the cold body in any system provided there is no heat exchange between the substances involved and their surrounding”*

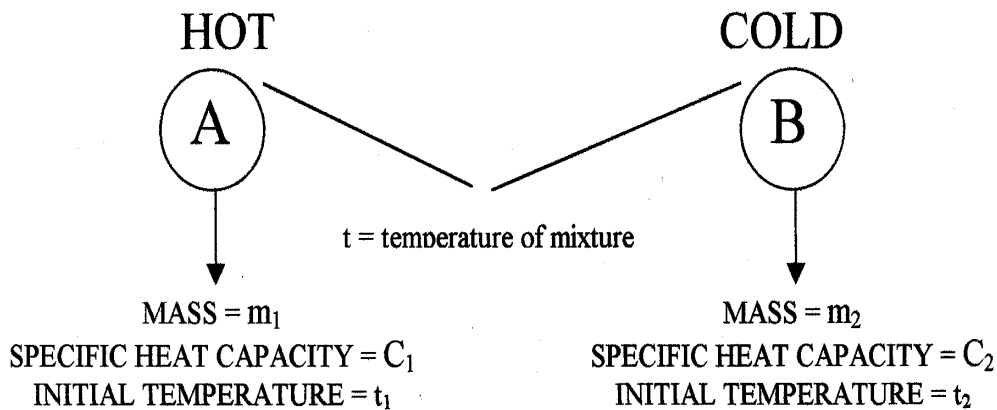
*But you may now ask: Is this always true?*

Unfortunately, this heat exchange cannot be completely true. However, the heat lost to the surrounding or gained from it can be reduced to a negligible amount by surrounding the container (calorimeter) with a bad conductor of heat (insulator). This process is called lagging.

In a laboratory, use the calorimeter as the container with which you observe exchange of heat between two substances, keeping them usually at different temperatures. The cold body is usually in form of water or any liquid and the hot body could be a solid body or liquid at a higher temperature.

Did you understand?

Let me illustrate this principle with this example,



**Fig. 3.1**

If body A is the hot body at temperature  $t_1$  and B is the cold body at temperature  $t_2$ , A and B are then mixed up to give a final temperature of mixture  $t$ . **Let us see then what has happened?**

- (1) The hot body has lost some heat to the cold body B. The heat lost can be find out.

Let  $Q_1$  be the amount of heat

$$Q_1 = m_1 c_1 \Delta\theta_1$$

$$\therefore Q_1 = m_1 c_1 \Delta\theta(t_1 - t)$$

$$\text{Or } Q_1 = -m_1 c_1 \Delta\theta(t - t_1) \dots\dots\dots (3.5)$$



- (2) The cold body B has gained some heat. The heat gained is,

Let  $Q_2$  be the amount of heat gained.

$$\begin{aligned} \therefore Q_2 &= m_2 c_2 \Delta\theta_2 \\ Q_2 &= m_2 c_2 \Delta\theta(t - t_2) \dots\dots\dots (3.6) \end{aligned}$$

- (3) How do you relate  $Q_1$  and  $Q_2$ ? We relate them together by using the principle of conservation of heat energy, which says that

“In any heat exchange provided heat is not lost to or gained from the surrounding.”

$$\begin{aligned} \text{Heat lost} &= \text{Heat gained} \\ \therefore Q_1 &= Q_2 \\ \therefore m_1 c_1 \Delta\theta_1 &= m_2 c_2 \Delta\theta_2 \\ \therefore m_1 c_1 (t_1 - t) &= m_2 c_2 (t - t_2) \dots\dots\dots (3.7) \end{aligned}$$

Out of all the seven quantities  $m_1$ ,  $c_1$ ,  $t_2$ ,  $t$ ,  $m_2$ ,  $c_2$  and  $t_1$  all will be known except one. Now try to look for this only unknown quantity.

Let us solve an SAQ to understand this more clearly.

### SELF ASSESSMENT EXERCISE 1

A piece of iron of mass 0.20kg is heated to 64°C and then dropped gently into 0.15kg of water at 16°C. If the temperature of the mixture is 22°C, what is the specific heat capacity of iron?

### 3.3.2 Inclusion of Calorimeter in Method of Mixtures

In section 3.3.1, we talked about simple method of mixtures in which the idea of the container taking part in the heat exchange was excluded. In this section, we are going to consider the calorimeter as one of the major players in the heat exchange (see Fig. 3.2). Once again, we shall still consider the principle of conservation of heat energy in our discussion.

Here we have the hot body A at a higher temperature than the liquid contained in the calorimeter. Thus, the liquid and the calorimeter are considered as the cold body gaining heat from the hot body.

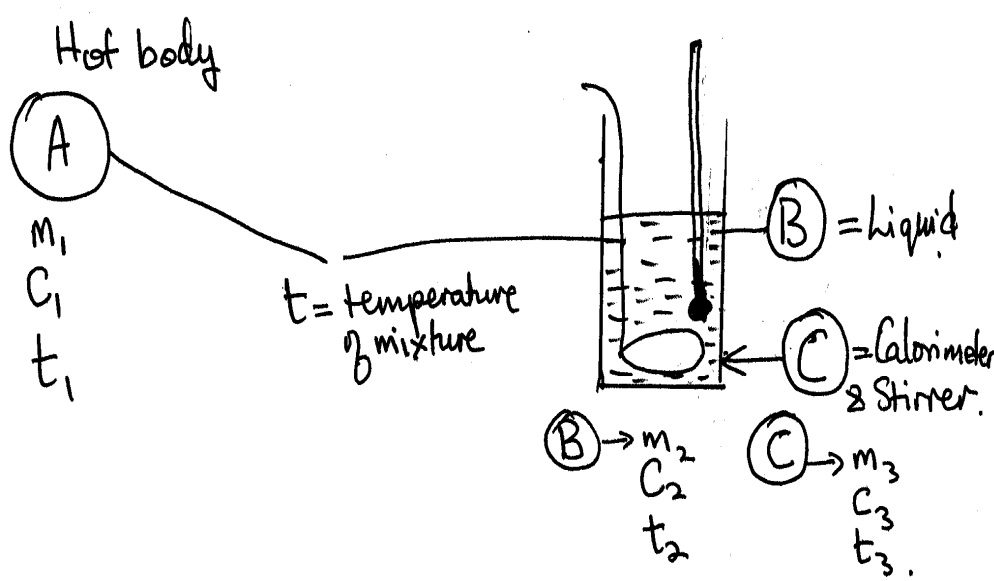


Fig. 3.2

Consider the hot body (A) with mass  $m_1$ , Specific heat capacity  $C_1$  its initial temperature  $t_1$  and Final temperature of mixture is  $t$ .

Then, Heat lost by hot body:

$$\begin{aligned}
 Q_1 &= m_1 c_1 \Delta\theta_1 \\
 Q_1 &= m_1 c_1 (t_1 - t) \dots\dots\dots (3.8)
 \end{aligned}$$

Again consider the cold liquid (B) with mass  $m_2$ , specific heat capacity  $C_2$  with initial temperature  $t_2$ . The final temperature of the mixture is  $t$ .

Heat gained by cold liquid (B) =  $Q_2$

$$\begin{aligned}
 Q_2 &= m_2 C_2 \Delta\theta_2 \\
 Q_2 &= m_2 C_2 (t - t_2) \dots\dots\dots (3.9)
 \end{aligned}$$

Consider the cold calorimeter (C) with mass  $m_3$ , specific heat capacity  $C_3$ , Specific heat capacity =  $C_3$  Initial temperature  $t_3$  and Final temperature of mixture  $t$ .

Heat gained by cold calorimeter C is  $Q_3$ .

$$\begin{aligned}
 Q_3 &= m_3 C_3 \Delta\theta_3 \\
 Q_3 &= m_3 C_3 (t - t_3) \dots\dots\dots (3.10)
 \end{aligned}$$

It can be noted here that the liquid (B) and calorimeter (C) are both gaining heat. Therefore their changes in temperature will be the same.

$$\therefore \Delta\theta_2 = \Delta\theta_3 \dots\dots\dots (3.11)$$

$$\therefore (t - t_2) = (t - t_3)$$

$$\therefore Q_3 = m_3C_3 (t - t_3) \dots\dots\dots (3.12)$$

In most cases,  $m_3$  and  $C_3$  may not be provided for you in the heat exchange. Rather, a property of the container, i.e. the calorimeter may be provided in the form of the thermal capacity (H) of the calorimeter. Hence, the quantity of heat gained by the calorimeter is expressed as

$$Q_3 = H\Delta\theta_3 = m_3C_3\Delta\theta_3 \dots\dots\dots (3.13)$$

$$\therefore Q_3 = H(t - t_2) \dots\dots\dots (3.14)$$

By applying the principle of conservation of heat energy, the relation between the quantities  $Q_1$ ,  $Q_2$  and  $Q_3$  is

$$\text{Heat lost} = \text{Heat gained}$$

$$Q_1 = Q_2 + Q_3 \dots\dots\dots (3.15)$$

$$\therefore m_1C_1 (t_1 - t) = m_2C_2 (t - t_2) + m_3C_3 (t - t_2)$$

$$\text{Or } m_1C_1 (t - t_1) = m_2C_2 (t - t_2) + H (t - t_2) \dots\dots\dots (3.16)$$

**SELF ASSESSMENT EXERCISE 2**

A calorimeter contains 0.30kg of water at 12°C. When poured in, the temperature of the mixture is found to be 52°C. What is the heat capacity of the calorimeter?

**3.4 Latent Heat**

When matter is heated, you will recall, there are three observable effects. Heat causes matter to:

- Expand
- Change its temperature
- Change its state

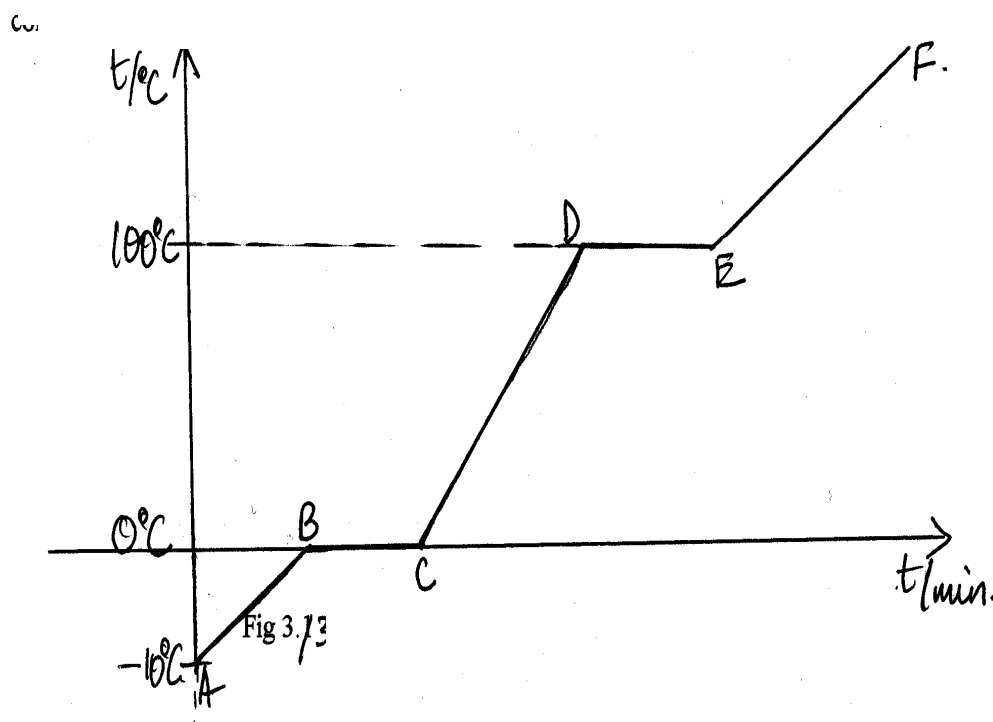
Let us look closely at the last two effects, changes in temperature and state. The first effect, expansion, will be considered later. The effect of

the temperature change has been used to measure the quantity of heat absorbed or given out by a substance. The expression used is  $Q = mC\Delta\theta$  (where  $\Delta\theta$  is the change in temperature).

***But what about the change in state?***

We shall now look critically at the effect of heat on a solid ice-block as it is heated from say  $-10^{\circ}\text{C}$  to the boiling point  $100^{\circ}\text{C}$ .

Fig 3.3 shows the graph of temperature versus time which allows us to understand the concept of Latent heat which is under discussion.



**Fig. 3.3**

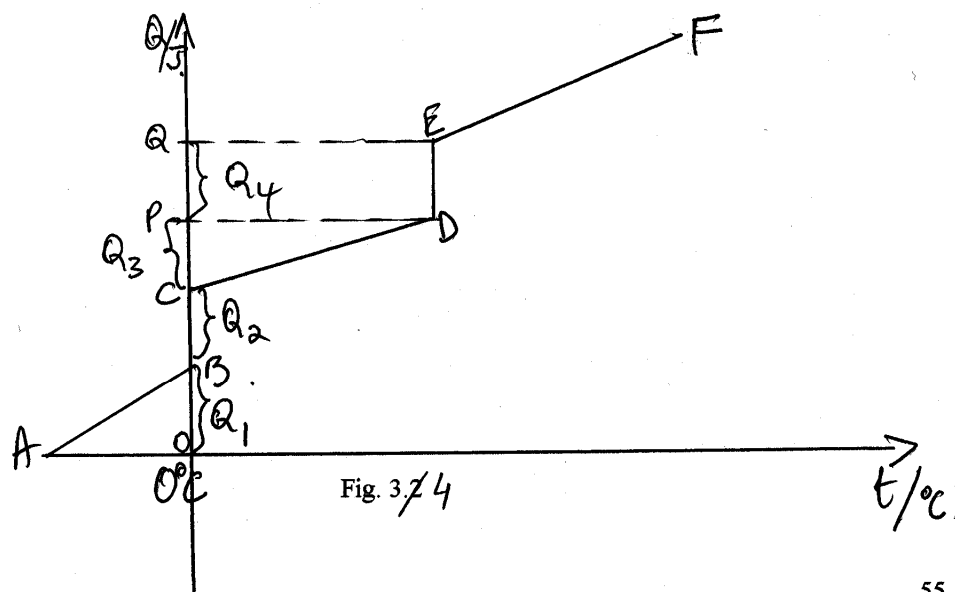
- AB shows increase in temperature as the time increases
- BC shows no increase in temperature with respect to time  
At this point the solid ice is observed to change its state from ice (solid) to water (liquid). This takes place at  $0^{\circ}\text{C}$  – the melting/freezing point of water. The process is called melting. The reverse process of melting is freezing.
- CD shows an increase in temperature with respect to time
- DE again shows no increase in temperature as the water is being heated. This happens at another fixed temperature of  $100^{\circ}\text{C}$  which is the boiling point of water. The liquid water changes its state from water to steam (gas). The process is called vapourization. The reverse process of vapourization is condensation.

- EF shows that there is an increase in temperature of steam with respect to time. In this region water behaves as a gas whose behaviour will be studied later.

It is significant to note that BC and DE show regions at which water changes its state from solid to liquid and from liquid to gas respectively. The reverse could also take place by extracting heat from the system then we have condensation, the reverse of vapourization and then freezing, the reverse of melting.

***But, how do we measure the heat content when water or any substance changes its state?***

To answer this question will therefore be involved with energy-temperature relationship of the processes of melting and vapourization or condensation and freezing.



**Fig. 3.4**

Refer to figure 3.4

- AB indicates the absorption of heat by the solid material to change its temperature from  $-10^{\circ}\text{C}$  to  $0^{\circ}\text{C}$ . The amount of heat supplied is  $OB = Q_1$ .

Where  $Q_1 = m_1 C_1 \Delta\theta_1$ . Here  $m_1$ , represents mass of ice, and  $m_1 =$  mass of ice,  $C_1$  is the specific heat capacity of solid ice is the change in temperature from  $-10^{\circ}\text{C}$  to  $0^{\circ}\text{C}$

$$\Delta\theta_1 = (0 - (-10))^\circ\text{C} = 10^\circ\text{C}$$

$$\therefore Q_1 = m_1 C_1 \times 10\text{J}$$

- BC corresponds to the absorption of heat energy without any change in temperature. The energy appears latent, that is, hidden since there is no change in temperature.

The amount of heat supplied to BC is  $Q_2 = mL_F$ , where,  $m$  is the mass of ice and  $L_F$  is the specific heat of fusion.

Latent heat of fusion  $L_F$  for ice =  $3.3 \times 10^5 \text{ Jkg}^{-1}$

**Specific latent heat of fusion is defined as the amount of heat required to change 1kg of mass of solid at its melting point to liquid at the same temperature”.**

- CD corresponds to the increase in temperature of substance in the liquid state.  $CP = Q_3 = mC_2\Delta\theta$  is the quantity of heat supplied to change its temperature from its melting point to  $100^\circ\text{C}$ , the boiling point. Here  $m$  is the mass of the liquid converted from solid ice,  $C_2$  is the specific heat capacity of water, and  $\Delta\theta_2$  is the change in temperature from  $0^\circ\text{C}$  to  $100^\circ\text{C}$ .
- DE shows that there is an increase in heat energy while the temperature does not change. DE therefore corresponds to the change in state from liquid to vapour. The heat energy appears latent, that is, hidden, since there was no change in temperature. The quantity of heat supplied is CP.

$$CP = Q_4 = mL_V$$

Where,  $m$  is the mass of water and  $L_V$  is the specific latent heat of vapourization at its boiling point.

Therefore, we can define the specific latent heat of vapourization of a liquid.

**“The specific latent heat of vaporization  $L_V$  of a liquid is the quantity of heat required to change 1kg of a liquid at its boiling point to vapour at the same temperature”.**

The value of  $L_V$  for water is  $2.4 \times 10^6 \text{ Jkg}^{-1}$  at  $100^\circ\text{C}$  and external pressure of 760mmHg.

- EF corresponds to the increase in temperature of the vapour. The heat absorbed by the vapour will depend on the condition under

which it is treated i.e. whether it is treated at constant pressure or at constant volume. These ideas will be discussed under the concept of molar heat capacity of gases at a later stage of your physics course.

You therefore need to understand the effects of heat on matter under consideration and to know the process it is undergoing when you are solving problems involving changes in temperatures and or changes in state. For example, the total heat energy required to change the mass  $m$  of ice at  $-10^{\circ}\text{C}$  to vapour at  $100^{\circ}\text{C}$  is  $Q$  where

$$Q = Q_1 + Q_2 + Q_3 + Q_4$$

$$Q = m_1 C_1 \Delta\theta_1 + mL_F + m_2 C_2 \Delta\theta_2 + mL_{V_s} \dots\dots\dots (3.17)$$

### SELF ASSESSMENT EXERCISE 3

1. How much heat is needed to melt 1.5kg of ice and then to raise the temperature of the resulting water  $50^{\circ}\text{C}$ ?

2. The water at  $0^{\circ}\text{C}$  is changed to  $50^{\circ}\text{C}$

$$Q_2 = m_1 C_1 \Delta\theta_1$$

$$= 1.5\text{kg} \times 4200\text{Jkg}^{-1} \text{ }^{\circ}\text{C}^{-1} \times (50-0)^{\circ}\text{C}$$

$$= 1.5\text{kg} \times 4200\text{Jkg}^{-1} \text{ }^{\circ}\text{C}^{-1} \times 50^{\circ}\text{C}$$

$$= 3.15 \times 10^5\text{J}$$

3. Total amount of heat required is

$$Q = Q_1 + Q_2$$

$$= 1.5\text{kg} \times 3.3 \times 10^5\text{Jkg}^{-1} + 1.5\text{kg} \times 4200\text{Jkg}^{-1} \text{ }^{\circ}\text{C}^{-1} \times 50^{\circ}\text{C}$$

$$= 4.95 \times 10^5\text{J} + 3.15 \times 10^5\text{J}$$

$$= 8.1 \times 10^5\text{J}$$

It can be concluded that there are two kinds of latent heat – the one at the melting point and the other at the boiling point. Thus we define

- **Latent heat of fusion as the heat required to melt a whole mass of solid at melting point to liquid at the same temperature.**
- **Latent heat of vapourization is the heat required to convert a whole mass of liquid at boiling point to vapour at the same temperature. It is expressed in joules per kilogram ( $\text{Jkg}^{-1}$ ).**

### 3.5 Explanation of Latent Heat

In this section, we would like to explain the meaning of latent heat of fusion and vapourization on the basis of kinetic molecular theory of matter.

#### 3.5.1 Specific Latent Heat of Fusion

A solid consists of atoms or molecules held in affixed structure by forces of attraction between them. These atoms or molecules vibrate about their mean position. When heat is therefore supplied to the solid, the kinetic energy of vibration increases thus increasing the temperature of the solid. The heat supplied is measure by  $mC\Delta\theta$  . At the melting point, the heat given to the solid is used to overcome the forces of attraction between the atoms or molecules, which keep the solid in its rigid form, and then the solid melts.

At this point we define the specific latent heat of fusion ( $L_F$ ) as *the quantity of heat required to change 1kg mass of a solid at its melting point to liquid at the same temperature.*

#### EXAMPLE 3.3

Explain the statement “the specific latent heat of fusion of ice  $3.3 \times 10^{-5} \text{ Jkg}^{-1}$ ”

#### Solution 3.3

This means that  $3.3 \times 10^{-5}$  joules of heat energy is required to change 1kg of solid ice at  $0^\circ\text{C}$  to 1kg of water at the same  $0^\circ\text{C}$  temperature.

#### 3.5.2 Specific Latent Heat of Vapourization

Unlike solids, a liquid has no definite form; it usually takes the shape of its container. Its molecules move in random manner inside although the molecules are close enough to attract each other. Some of the molecules, which have the greatest kinetic energy, are able to escape through the surface. They then exist as vapour outside the liquid. This process is called evaporation and it takes place at all temperatures.

However, boiling occurs at a definite temperature, the boiling point which depends on the external pressure. Water for example boils at  $100^\circ\text{C}$  and at a pressure 760mmHg. It does so at a lower temperature when the external pressure is lower e.g. boiling point of water at the top of a mountain is less than  $100^\circ\text{C}$ . Boiling occurs throughout the whole volume of the liquid whereas evaporation is a surface phenomenon.



At this point, we would define the specify latent heat of vapourization as *the quantity of heat required to change 1kg mass of liquid at boiling point to vapour at the same temperature.*

#### SELF ASSESSMENT EXERCISE 4

How much heat is given out when 50g of steam at 100°C cool to water at 28°C? (Specific latent heat of vapourization of water =  $2.3 \times 10^6$  J/kg).

### 3.5.3 Latent Heat and Internal Energy

When a liquid reaches its boiling point, the energy needed to change it to vapour is:

- (i) the energy or work needed to separate the liquid molecules from their mutual attraction until they are relatively far apart in the gaseous state.
- (ii) the energy or work needed to push back the external pressure so that the molecules can escape from the liquid.

The latent heat of vapourization is used in point (i) which is needed to change the internal energy of the liquid whereas point (ii) is the external work done against the external pressure.

The work done in this case is defined as

$$W = p\Delta V \dots\dots\dots (3.18)$$

Where, p is the external pressure and  $\Delta V$  is the change in volume  
1g of water changes to about 1672cm<sup>3</sup> of steam

$$\begin{aligned} \therefore \Delta V &= (1672 - 1)\text{cm}^3 \\ &= 1671 \times 10^{-6}\text{cm}^3 \end{aligned}$$

Assuming the external pressure  
 $P = 1.013 \times 10^5 \text{ N m}^{-2}$

$$\begin{aligned} \therefore \text{The work done (W)} &= p\Delta V \text{ is therefore} \\ &= 1.0 \times 10^5 \frac{\text{N}}{\text{m}^2} \times 1671 \times 10^{-6} \text{m}^3 \\ &= 169.3\text{J} \end{aligned}$$

The latent heat of vapourization per gram of water = 2260J

Thus the internal energy part of the latent heat of vaporization

$$\begin{aligned}
 &= (2260 - 169.3)\text{J} \\
 &= 2090.7\text{J}
 \end{aligned}$$

This is much greater than the external work done.

The latent heat of fusion is about 340J. So the energy needed to overcome the bonds between molecules in the solid state is much less than the energy to form the gaseous molecules from the liquid state.

### SELF ASSESSMENT EXERCISE 5

1g of steam condenses to water 100 °C. Estimate the change in potential energy per molecule, given that the latent heat of vapourization is 2240J and that Avogadro's constant is  $6 \times 10^{23}$  per mole. (Assume no heat is gained from or lost to the surrounding).

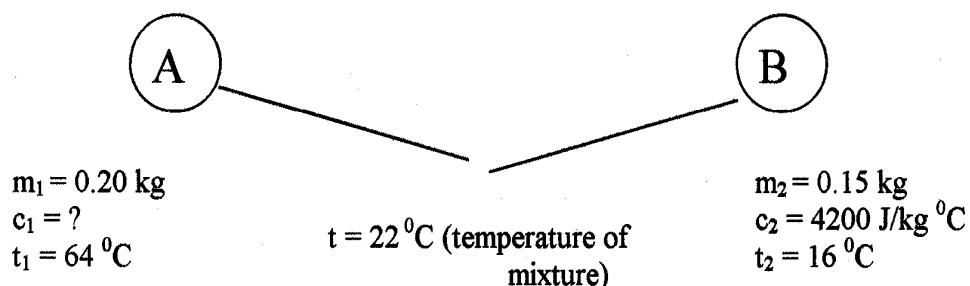
## 4.0 CONCLUSION

The three basic effects of heat have been identified under this unit. The effects are expansion, change in temperature and change in state. The change in temperature and change in state have been associated with the measurement of heat. With the change in temperature, the quantity of heat is expressed as  $Q = mC\Delta\theta$ , whereas for the change in state the heat required is given as  $Q = mL_F$  or  $Q = mL_V$ .

## 5.0 SUMMARY

In this unit you have learnt that:

- Heat is a form of energy and is measured in joules (J)
- The heat capacity of a substance is the quantity of heat required to change the temperature of the body through 1°C.
- The specific heat capacity of a substance is the quantity of heat in joules that is required to change the temperature of 1kg mass of the substance through 1°C.
- The specific latent heat of fusion of a solid is the quantity of heat in joules that is required to change the state of 1kg mass of the solid at the melting point to liquid at the same temperature.
- The specific latent heat of vapourization of a liquid is the quantity of heat in joules required to change 1kg mass of the liquid at its boiling point to gas at the same temperature.

**ANSWER SELF ASSESSMENT EXERCISE 1****HOT – IRON****COLD – WATER**

$$\begin{aligned} \text{Heat lost by iron, } Q_1 &= m_1 c_1 \Delta\theta_1 \\ &= m_1 c_1 (t_1 - t) \\ &= 0.20\text{kg} \times c_1 \times (64 - 22)^{\circ}\text{C} \end{aligned}$$

$$\begin{aligned} \text{Heat gained by water, } Q_2 &= m_2 c_2 \Delta\theta_2 \\ &= m_2 c_2 (t - t_2) \\ &= 0.150\text{kg} \times 4200 \text{Jkg}^{-1}\text{C}^{-1} \times (22 - 16)^{\circ}\text{C} \end{aligned}$$

Using the principle of conservation of heat energy,

$$\begin{aligned} \therefore \text{Heat lost by iron} &= \text{Heat gained by water} \\ \therefore Q_1 &= Q_2 \end{aligned}$$

$$0.2\text{kg} \times c_1 \times (64 - 22)^{\circ}\text{C} = 0.150\text{kg} \times 4200 \text{Jkg}^{-1}\text{C}^{-1} \times (22 - 16)^{\circ}\text{C}$$

$$\therefore c_1 = \frac{0.15 \times 4200 \times 6\text{J}}{0.02\text{kg} \times 42^{\circ}\text{C}}$$

$$c_1 = 450 \text{Jkg}^{-1}\text{C}^{-1}$$

**ANSWER SELF ASSESSMENT EXERCISE 2**

The question is centered on determining H, the heat (thermal) capacity of the container (Calorimeter).

$$\begin{aligned} 1. \quad \text{Heat lost by hot water} &= Q_1 \text{ and} \\ Q_1 &= m_1 C_1 \Delta\theta_1 \\ \text{Where } m_1 &= 0.4\text{kg,} \\ C_1 &= \text{specific heat capacity of water} = 4200 \text{Jkg}^{-1}\text{C}^{-1} \text{ and} \\ \Delta\theta_1 &= (t_1 - t) = (84 - 52)^{\circ}\text{C} \\ Q_1 &= 0.4\text{kg} \times 4200 \text{Jkg}^{-1}\text{C}^{-1} \times (84 - 52)^{\circ}\text{C} \\ &= 0.4 \times 4200 \times 32\text{J} \end{aligned}$$

2. Heat gained by cold water in the calorimeter =  $Q_2$  and

$$Q_2 = m_2 C_2 \Delta\theta_2$$

Where  $m_2 = 0.3\text{kg}$ ,

$C_1 =$  specific heat capacity of water =  $4200\text{Jkg}^{-1}\text{C}^{-1}$  and

$$\Delta\theta_2 = (t - t_2) = (52 - 12)^\circ\text{C} = 40^\circ\text{C}$$

$$\begin{aligned} Q_2 &= 0.3\text{kg} \times 4200\text{Jkg}^{-1}\text{C}^{-1} \times 40^\circ\text{C} \\ &= 0.3 \times 4200 \times 40\text{J} \end{aligned}$$

3. Heat gained by cold water calorimeter =  $Q_3$  and

$$Q_3 = H\Delta\theta_3 \text{ (where } H = \text{thermal heat capacity of the calorimeter)}$$

$$= H\Delta\theta_2$$

$$= (t - t_2)$$

$$= H(52 - 12)^\circ\text{C}$$

$$= H \times 40^\circ\text{C}$$

By applying the conservation of heat energy

$$\text{Heat lost} = \text{Heat gained}$$

$$\therefore Q_1 = Q_2 + Q_3$$

$$\therefore m_1 C_1 (t_1 - t) = m_2 C_2 (t - t_2) + m_3 C_3 (t - t_2)$$

$$\therefore 0.4 \times 4200 \times 32\text{J} = 0.3 \times 4200 \times 40\text{J} + H \times 40^\circ\text{C}$$

$$\therefore 53760\text{J} = 50400\text{J} + H \times 40^\circ\text{C}$$

$$\therefore 53760\text{J} - 50400\text{J} = H \times 40^\circ\text{C}$$

$$\begin{aligned} \therefore H &= \frac{3360\text{J}}{40^\circ\text{C}} \\ &= 84\text{J}/^\circ\text{C}^{-1} \end{aligned}$$

The heat capacity of the calorimeter is  $84\text{J}/^\circ\text{C}$

### ANSWER SELF ASSESSMENT EXERCISE 3



1. The ice melts at

Quantity of heat used in melting =  $Q$  and

$$Q_1 = mL_F$$

Where,  $m =$  mass of ice and  $L_F =$  specific latent heat of fusion

$$= 1.5\text{kg} \times 3.3 \times 10^5\text{Jkg}^{-1}$$

$$= 4.95 \times 10^5$$

**ANSWER SELF ASSESSMENT EXERCISE 4**

The steam condensed at 100°C.

Therefore, heat given out is  $Q_1 = mL$

$$\begin{aligned} \text{Where } m &= \text{mass of steam} = (50/1000) \text{ kg} \\ L_v &= \text{specific latent heat of vapourization of water} \\ &= 2.3 \times 10^6 \text{ J/kg} \\ \therefore Q_1 &= (50/1000) \text{ kg} \times 2.3 \times 10^6 \text{ J/kg} \\ &= (50/1000) \times 2.3 \times 10^6 \text{ J} \\ Q_1 &= 0.115 \times 10^6 \text{ J} \end{aligned}$$

To cool from 100°C to 28°C, Heat given out by steam

$$Q_2 = mC\Delta\theta$$

$$\begin{aligned} \text{Where, } m &= (50/1000) \text{ kg mass of water} \\ C &= \text{specific heat capacity of water } 4200 \text{ Jkg}^{-1}\text{C}^{-1} \\ &= \text{change in temperature} = (100 - 28)^\circ\text{C} \\ \therefore Q_2 &= (50/1000) \text{ kg} \times 4200 \text{ Jkg}^{-1}\text{C}^{-1} \times (100 - 28)^\circ\text{C} \\ &= (50/1000) \times 4200 \times 72 \text{ J} \\ &= 15120 \text{ J} \end{aligned}$$

$$\begin{aligned} \therefore \text{Total heat given out} &= Q = Q_1 + Q_2 \\ Q &= 0.115 \times 10^6 \text{ J} + 15120 \text{ J} \\ &= 1.15 \times 10^5 \text{ J} + 0.1512 \times 10^5 \text{ J} \\ Q &= 1.30 \times 10^5 \text{ J} \end{aligned}$$

**ANSWER SELF ASSESSMENT EXERCISE 5**

1 mole of water ( $\text{H}_2\text{O}$ ) = 18g

If 18g of  $\text{H}_2\text{O}$  contains  $6 \times 10^{23}$  molecules

$\therefore$  1g of water contains  $\frac{6 \times 10^{23}}{18}$  molecules

Hence the change in Potential energy ( $\Delta\text{PE}$ ) per molecule

$$\begin{aligned} &= 2240 \text{ J} \div \frac{6 \times 10^{23} \text{ molecules}}{18} \\ &= 2240 \text{ J} \times \frac{18}{6 \times 10^{23} \text{ molecule}} \end{aligned}$$

$$= \frac{2240 \times 18}{6} \times 10^{-23} \frac{\text{J}}{\text{molecule}}$$

$$= 6.72 \times 10^{-20} \frac{\text{J}}{\text{molecule}}$$

## 6.0 TUTOR-MARKED ASSIGNMENT

1. An iron casting of mass 30kg at 400°C is being cooled and it gives out heat on an average of 920J/s. Calculate its temperature after 1 hour? (Specific heat capacity of iron = 460Jkg<sup>-1</sup>°C<sup>-1</sup>).
2. A piece of iron of mass 0.27kg is immersed in boiling water and then dropped into 0.10kg alcohol at 27°C. If the final mixture is 50°C, what is the specific heat capacity of alcohol? (Specific heat capacity of iron = 460Jkg<sup>-1</sup>°C<sup>-1</sup>).
3. A copper calorimeter of mass 150g contains 100g of water at 16°C. 250g of a metal at 100°C are dropped into the water and the temperature of the mixture is 37°C. What is the specific heat capacity of the metal? (Specific heat capacity of copper = 400Jkg<sup>-1</sup>°C<sup>-1</sup>).
4. What mass of ice is needed to cool 60g of water from 43°C to 20°C?
5. Specific Latent Heat of Fusion of Lead is 2.1 x 10<sup>4</sup>J/kg and its melting point is 328°C. How many joules will be needed to melt 7.0kg of lead at 13°C? (Specific heat capacity of lead = 120Jkg<sup>-1</sup>°C<sup>-1</sup>)

## 7.0 REFERENCES/FURTHER READING

- Awe, O. and Okunola, O. O. (1986). *Comprehensive Certificate Physics*, Ibadan: University Press, Limited.
- Ference, M. (Jnr.), Lemon, H.B. and Stephenson, R. J. (1970). *Analytical Experimental Physics*, Chicago: The University of Chicago Press.
- Feynman, R. P., Leighton, R. B. and Sands, M. (1971). *The Feynman Lectures on Physics*, California: Addison – Wesley Publishing Company.
- Flowers, B. H. and Mendoza, E. (1970). *Properties of Matter*, London: John Wiley and Sons Limited.

- Noaks, M. A. (1963). *New Intermediate Physics*, Canada: Macmillan and company Limited.
- Soars, F. W., Zemansky, M.W. and Young, H. D. (1980). *College Physics*, London: Addison – Wesley Publishing Company.
- Tyler, F.(1966). *Heat and Thermodynamics*, London: Edward Arnold Publisher Limited.
- Wilkinson, J. (1983). *Essentials of Physics*, Australia: McMillan Education Publisher.
- Zemansky, M. W. (1968). *Heat and Thermodynamics*, New York: McGraw Hill.

## UNIT 4 THERMAL EXPANSION

### CONTENTS

- 1.0 Introduction
- 2.0 Objectives
- 3.0 Main Content
  - 3.1 Thermal Expansion in Solids
    - 3.1.1 Linear Expansion
    - 3.1.2 Determination of Linear Expansion
    - 3.1.3 Superficial Expansion
    - 3.1.4 Cubical Expansion
    - 3.1.5 Applications of Expansivity
  - 3.2 Thermal Expansion in Liquids
    - 3.2.1 Cubical Expansion
    - 3.2.2 Real and Apparent Expansion of Liquids
- 4.0 Conclusion
- 5.0 Summary
- 6.0 Tutor-Marked Assignment
- 7.0 References/Further Reading

### 1.0 INTRODUCTION

In unit 3, we discussed the three effects of matter, namely, expansion, change in temperature and change in state. We were able to show how heat can be measured using the ideas of change in temperature, the specific heat capacity, the mass of the body, specific latent heat of fusion and vapourization to determine the heat absorbed or given out by the body in question.

Broadly, there are these states of matter, solids, liquids and gases. We shall consider the expansion of solid and liquids in this unit. In this unit we are going to examine the expansion/contraction of a material when it is heated or cooled. The expansion of gases will be the subject of the next unit.

### 2.0 OBJECTIVES

At the end of this unit, you should be able to:

- explain thermal expansion in solids and liquids
- define linear, superficial and cubical expansion on a matter
- apply the expansion of matter to day-to-day activities
- solve problems on the expansion of solids and liquids.



### 3.0 MAIN CONTENT

#### 3.1 Thermal Expansion in Solids

We know, from our elementary knowledge, that matter is anything that has weight and occupies space. In that case, solids, liquids and gases are forms of matter. When they are therefore heated, experience has shown that they expand. In this unit, we shall examine the expansion of solids and liquids only. It is interesting to know that not only expansion is noticeable in matter when it is heated, but also a change in temperature is also noticeable as heat is absorbed by or removed from the body.

When solids are heated, the effect of heat on them could be found in the change of:

- the length
- the area and
- volume of the solids as temperature changes.

The changes in length, area and volume of the solids depends on:

- the material making up the solid;
- the range of the temperature change;
- the initial dimensions of the solid.

From the above three factors we could deduce that

- the expansion of solids varies from one material to the other;
- the greater the range of temperature change, the greater the expansion;
- expansion depends on the original length, area and volume of the solid.

##### 3.1.1 Linear Expansion

Here, we shall discuss the linear i.e. straight-line expansion of the material. This means we are considering the expansion of a solid in one dimension only.

Consider a metal rod with an original length  $\ell_0$  (fig. 3.1(i)). If such a length of material is heated from an initial temperature  $t_1^\circ\text{C}$  to  $t_2^\circ\text{C}$ , the change in temperature  $\Delta\theta$  is given as

$$\Delta\theta = (t_2 - t_1)^\circ\text{C}$$

It will be noticed that the length of the metal rod increased from  $l_0$  to  $l_t$  (fig. 3.11(ii))  $l_t$  is the new length at temperature  $t_2^\circ\text{C}$  and  $l_0$  is the original length at temperature  $t_1^\circ\text{C}$ .

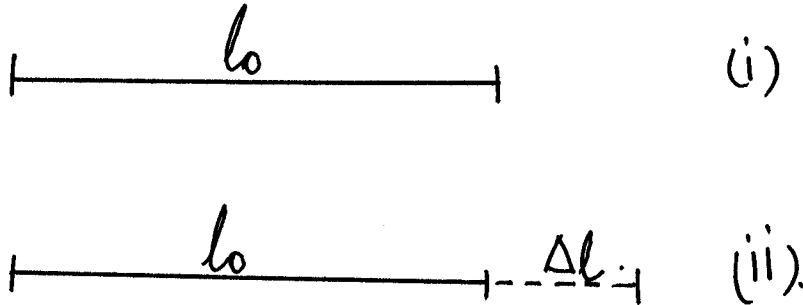


Fig. 3.1

The new length  $l_t$  is therefore given as

$$l_t = l_0 + \Delta l$$

Where  $\Delta l$  is the change in length of the rod when heated from  $t_1^\circ\text{C}$  to  $t_2^\circ\text{C}$

$$\therefore \Delta l = l_t - l_0 \dots\dots\dots (4.1)$$

It is found experimentally that for a given material, the increase in length,  $\Delta l$ , is proportional directly to

- (i) the original length  $l_0$  and
- (ii) the change in temperature  $\Delta\theta$

$$\therefore \Delta l = \alpha l_0 \Delta\theta \dots\dots\dots (4.2)$$

Where,  $\alpha$  is the constant of proportionality which is known as the coefficient of linear expansion of the solid or in short, linear expansivity. Consequently  $\alpha$  can be given as,

$$\alpha = \frac{\Delta l}{l_0 \Delta\theta}$$

Thus by definition,  $\alpha$ , the linear expansivity is “**The increase in length of the material ( $\Delta l$ ) per the original  $l_0$  length per degree Celsius change in temperature ( $\Delta\theta$ ).**”

The unit of  $\alpha$  is  $^{\circ}\text{C}^{-1}$  or per degree Celsius.

On comparing Eq. (4.1) and (4.2), we get

$$\therefore l_t - l_o = \alpha l_o \Delta\theta$$

$$\therefore l_t - l_o = \alpha l_o \Delta\theta$$

$$\therefore l_t - l_o = \alpha l_o (t_2 - t_1) \dots \dots \dots (4.3)$$

### Example 1

An iron rail is 20m long. How much will it expand when heated from  $10^{\circ}\text{C}$  to  $50^{\circ}\text{C}$  (linear expansivity of iron =  $1.2 \times 10^{-5} \text{ }^{\circ}\text{C}^{-1}$ )?

### Solution

Let the original length of iron =  $l_o = 20\text{m}$

Let the initial temperature  $t_1^{\circ}\text{C} = 10^{\circ}\text{C}$

And the final temperature  $t_2^{\circ}\text{C} = 50^{\circ}\text{C}$

$$\begin{aligned} \therefore \text{Change in temperature } \Delta\theta &= (t_2 - t_1)^{\circ}\text{C} \\ &= (50 - 10)^{\circ}\text{C} \\ &= 40^{\circ}\text{C} \end{aligned}$$

Given that  $\alpha$  for iron =  $1.2 \times 10^{-5} \text{ }^{\circ}\text{C}^{-1}$

From  $\Delta l = \alpha l_o \Delta\theta$

$$\therefore \text{The change in length } \Delta l = \alpha l_o \Delta\theta$$

$$\begin{aligned} \therefore \Delta l &= 1.2 \times 20\text{m} \times 40^{\circ}\text{C} \\ &= 0.0096\text{m} \\ \Delta l &= 0.96\text{cm}. \end{aligned}$$

The iron rail would have expanded by 0.96cm.

After this example, you must have observed the values of  $\alpha$  and  $\Delta l$ .

You would have observed that the value of  $\alpha$  is very small not only for iron but for most materials as you will further observe in Table 3.1. below.

## Linear Expansivities for Some Materials

**Table 3.1**

Substance	Value
<b>Pure Metals</b>	
Aluminum	$2.55 \times 10^{-5} \text{C}$
Copper	$1.67 \times 10^{-5} \text{C}$
Gold	$1.395 \times 10^{-5} \text{C}$
Iron	$1.20 \times 10^{-5} \text{C}$
Nickel	$1.28 \times 10^{-5} \text{C}$
Platinum	$0.80 \times 10^{-5} \text{C}$
Silver	$1.88 \times 10^{-5} \text{C}$
<b>Alloys</b>	
Brass	$1.89 \times 10^{-5} \text{C}$
Constantan	$1.70 \times 10^{-5} \text{C}$
Invar	$0.10 \times 10^{-5} \text{C}$
Phosphor – Bronze	$1.68 \times 10^{-5} \text{C}$
Solder (2pb: 1Sn)	$2.50 \times 10^{-5} \text{C}$
Steel	$1.10 \times 10^{-5} \text{C}$

### 3.1.2 Determination of Linear Expansion ( $\alpha$ )

In the earlier section, you have learnt about linear expansion  $\alpha$ . We can measure the value of  $\alpha$  by various methods.

We have the following methods used in determining the linear expansivity ( $\alpha$ ) of a metal:

- Optical lever method
- Screw gauge method
- Comparator method
- Henning's tube method
- Fizeau's method

All the above methods are different in the manner in which the increase in length is measured. The specimen to be measured is in form of a bar or tube and this involves:

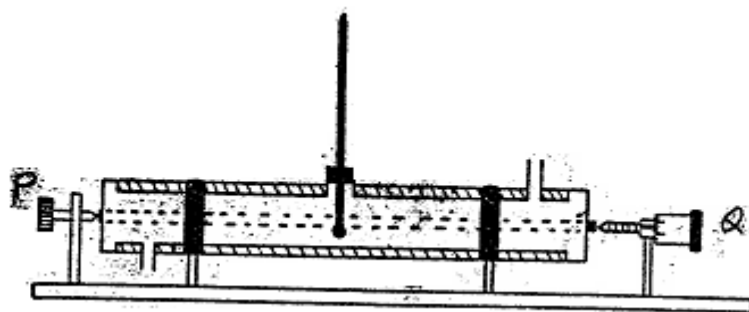
- the measurement of the length of the bar,
- the rise in temperature during the experiment and

- the increase in length of the bar consequent on this rise in temperature.

The first two measurements do not present any great difficulty, but the actual measurement of the expansion that takes place. It is therefore this measurement of the increase in expansion that has called for use of elaborate vernier microscope, micrometer screw gauge and the optical lever method. We shall describe the screw gauge method here.

### The Screw Gauge Method

This is one of the laboratory methods for determining the coefficient of linear expansion of a metal. The apparatus used for the determination of  $\alpha$  is as shown in fig. 3.2.



**Fig. 3.2: Linear Expansivity Apparatus with Screw Gauge**

The metal rod which is placed in the tube AB is about a meter in length. It is supported horizontally by pillars P and Q on a firm base.

The end A of the tube is in contact with the fixed end of the pillar of the apparatus. The screw gauge makes contact with the other end B as shown in fig. 3.2.

The reading of the screw gauge is taken when it is initially in contact with the end B at the room temperature  $t_1$ .

The screw gauge is then screwed backward to give room for the expansion of the rod inside the tube.

Steam is allowed into the tube at end A and out through end B for a considerable length of time so that the rod acquires at temperature of  $100^\circ\text{C}$ , the temperature of steam ( $t_2$ ).

The screw is then screwed up to make contact with the rod when fully expanded. The new reading on the screw gauge is then taken. The difference of the two readings on the screw gauge gives the increase in length of the rod due to expansion.

If the original length of the rod is  $\ell_0$ , the increase in length is  $\Delta \ell$  and the change in temperature is  $\Delta \theta = (t_2 - t_1) = (100 - t_1)^\circ\text{C}$ , where  $t_1$  is the room temperature, then the coefficient of expansion  $\alpha$  is determined as

$$\alpha = \frac{\Delta \ell}{\ell_0 \Delta \theta}$$

$$\alpha = \frac{\Delta \ell_{(m)}}{\ell_{0(m)} (100 - t_1)^\circ\text{C}} \dots\dots\dots (4.4)$$

### 3.1.3 Superficial Expansion

Under this section, we shall consider the expansion of material in two dimensions (-length and breadth) to produce an area expansion.

When a solid is heated, the area increases. In this case the expansion or the change in area is in two dimensions as shown in fig. 3.3(ii).

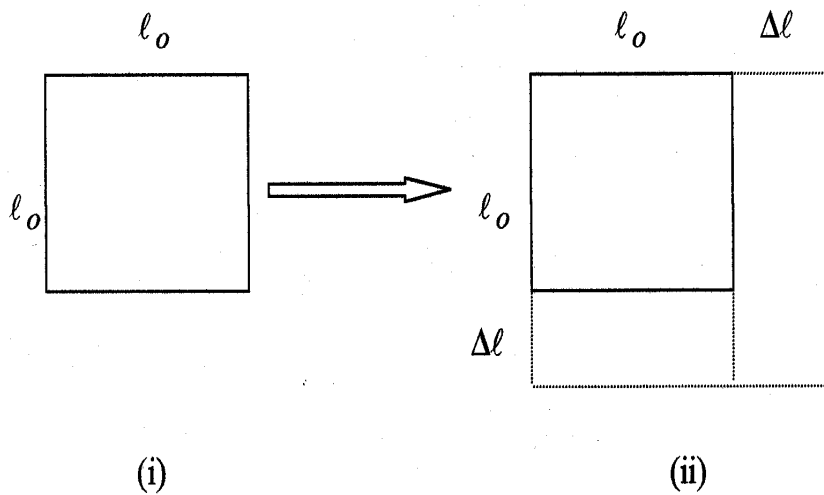


Fig. 3.3

Consider a square solid object of length  $\ell_0$  (fig.3.3(ii)). By definition its original area at initial temperature  $t_1^\circ\text{C}$  is  $A_0 (= \ell_0^2)$ .

If the object is heated from temperature  $t_1^\circ\text{C}$  to  $t_2^\circ\text{C}$ , then each length would have increased by  $\Delta \ell$  (fig. 3.3 (ii)).

Then the new area  $A_t = (\ell_0 + \Delta \ell)^2$

Thus, the change in area  $\Delta A$  is given as

$$\Delta A = A_t - A_0$$

and the change in temperature  $\Delta \theta$  is given as

$$\Delta \theta = (t_2 - t_1)^\circ\text{C}$$

Again, experiments have shown that for a given material, the change in area ( $\Delta A$ ) is directly proportional to the original area  $A_o$  and the change in temperature  $\Delta\theta$ .

$$\therefore \Delta A = \beta A_o \Delta\theta \dots\dots\dots (4.5)$$

where,  $\beta$  is the constant of proportionality otherwise known as the coefficient of superficial expansion or in short area expansivity of the material.

$$\begin{aligned} \therefore A_t - A_o &= \beta A_o \Delta\theta \\ \therefore A_t &= A_o + \beta A_o \Delta\theta \\ \therefore A_t &= A_o (1 + \beta A_o \Delta\theta) \dots\dots\dots (4.6) \end{aligned}$$

So far we have learnt about  $\alpha$  and  $\beta$ . Let us see, that there is any relationship between the linear expansivity ( $\alpha$ ) of a material and the area expansivity ( $\beta$ ) of the same material. We shall proceed to show this relationship.

Given that from Eq. (4.6), that  $A_t = (\ell_o + \Delta\ell)^2$

On expanding the expansion  $(\ell_o + \Delta\ell)^2$ , we get

$$\therefore A_t = (\ell_o^2 + 2\ell_o\Delta\ell + \Delta\ell)^2 \dots\dots\dots(4.7)$$

You know that  $\Delta\ell = \alpha \ell_o \Delta\theta \dots\dots\dots (4.8)$

But

Therefore, Eq. (4.7) becomes

$$\begin{aligned} A_t &= \ell_o^2 + 2\ell_o\alpha\ell_o\Delta\theta + \alpha^2\ell_o^2(\Delta\theta)^2 \\ &= \ell_o^2 + 2\alpha\ell_o^2\Delta\theta + \alpha^2\ell_o^2(\Delta\theta)^2 \end{aligned}$$

But  $\ell_o^2 = A_o$

On arranging the terms, we get

$$\therefore A_t = A_o + 2\alpha A_o \Delta\theta + \alpha^2 A_o (\Delta\theta)^2 \dots\dots\dots(4.9)$$

You will recall that the value of  $\alpha$  is very small ( $10^{-5}$ ) therefore  $\alpha^2$  will be so small that term  $\alpha^2$  the expression can be ignored.

$$\therefore A_t = A_o + 2\alpha A_o \Delta\theta \text{ compare with}$$

$$A_t = A_o + \beta A_o \Delta\theta$$

Hence  $\beta = 2\alpha$  ..... (4.10)

That is, the coefficient of superficial expansion  $\beta$  is twice the value of the coefficient of linear expansion.

It means that when problems are set on superficial expansion, you will not be given the value of  $\beta$  but you will be given the value  $\alpha$  of for the material. At this point, you must remember the relationship.

$$\beta = 2\alpha$$

**SELF ASSESSMENT EXERCISE 1**

A square sheet of steel has a side of 15cm at 0°C. Determine its area at 40°C.

Given: coefficient of linear expansivity of steel =  $1.1 \times 10^{-5}C^{-1}$ )

**3.1.4 Cubical Expansion**

The volume of a solid increases as a result of heat. Let the original volume of the cube as shown in fig. 3.4(i) be  $V_o$  at initial temperature  $t_1^\circ C$ . If the cube is heated to a temperature  $t_2^\circ C$ , then the new volume at temperature  $t_2^\circ C$  is  $V_t$  (fig. 3.4(ii)).

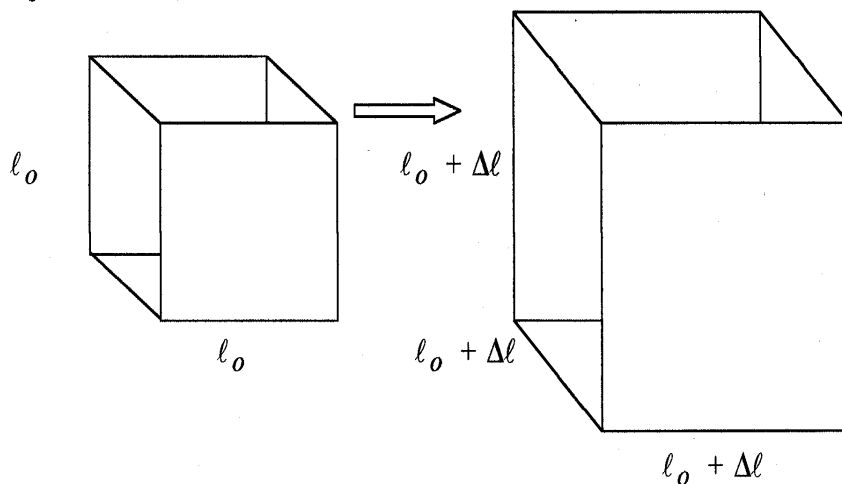
There is a change in volume given by

$$\Delta V = V_t - V_o$$

The change in volume is directly proportional to the

$$(\ell_o = \Delta \ell)$$

$$(\ell_o + \Delta \ell)$$



**Fig. 3.4**



Original volume  $V_o$  and the change in temperature  $\Delta\theta$

$$\therefore \Delta V = \gamma V_o \Delta\theta$$

where  $\gamma$  is a constant of proportionality the coefficient of cubical expansion, or cubical expansivity.  $\alpha$  is defined as,

$$\gamma \frac{\Delta V}{V_o \Delta\theta} \dots\dots\dots (4.11)$$

The increase in volume per original volume per degree Celsius rise in temperature.

$$\begin{aligned} \text{If } \Delta V &= \gamma V_o \Delta\theta \\ \text{But } V_t &= V_o + \Delta V \\ \therefore V_t &= V_o + \gamma V_o \Delta\theta \\ V_t &= V_o (1 + \gamma \Delta\theta) \dots\dots\dots (4.12) \end{aligned}$$

Again, one can establish between the cubical expansivity  $\gamma$  and the linear expansivity  $\alpha$ .

From fig. 3.4(i) we know that

$$V_o + l_o^3 \dots\dots\dots (4.13)$$

and from fig. 3.4(ii) we also note the

$$V_t = (l_o + \Delta l)^3 \dots\dots\dots (4.14)$$

by expanding  $(l_o + \Delta l)^3$  we obtain

$$V_t = l_o^3 + 3\alpha l_o^3 \Delta\theta + 3 l_o^3 \alpha^2 (\Delta\theta)^2 + \alpha^3 l_o^3 \Delta\theta^3$$

By using the previous argument that the value of  $\alpha$  is very small, therefore  $\alpha^2$ ,  $\alpha^3$  will be so small that the expressions in terms of  $\alpha^2$  and  $\alpha^3$  can be ignored.

Consequently

$$\begin{aligned} V_t &= l_o^3 + 3\alpha l_o^3 \Delta\theta \quad \text{since } l_o^3 = V_o \\ V_t &= V_o + 3\alpha V_o \Delta\theta \dots\dots\dots (4.15) \end{aligned}$$

$$\text{But, } V_t = V_o + \gamma V_o \Delta\theta \dots\dots\dots (4.16)$$

On comparing Eq. (4.15) and Eq. (4.16), we can conclude that  $\gamma$  is three times as large as  $\alpha$

That is the volume of expansivity is three times  $r = 3\alpha$  the linear expansivity ..... (4.17)

## SELF ASSESSMENT EXERCISE 2

The volume of a small piece of metal is  $5.000\text{cm}^3$  at  $20^\circ\text{C}$  and  $5.014\text{cm}^3$  at  $100^\circ\text{C}$ . Determine the cubic expansivity of the metal?

### 3.1.5 Applications of Expansivity

The following are some practical applications of expansivity:

1. Some metals such as platinum and tungsten have their linear expansivity very close to that of glass. Beside the fact that the linear expansivity of platinum is almost equal to that of glass, the behaviour of these solids are very much alike. This characteristics feature therefore enables us to seal electrodes through glass without the occurrence of breakage through cooling and heating processes.
2. Linear expansivity is also applied in the formation of bimetallic element which are used as:
  - (i) thermostatic control switches;
  - (ii) in the construction of expansion loops for use in steam lines;
  - (iii) bimetallic thermometers.
3. Linear expansivity is also used in the construction of bridges where gaps are left between the girders to accommodate expansion. Such gaps are also between the iron rails in the construction of railway lines.

### Example 2

Have you ever noticed that the electric wires on the NEPA poles are always left sagging? Can you explain why this is so?

### Solution

This is to allow for changes in length as the temperature changes. If they are taut further cooling in the atmosphere may make them snap.

## 3.2 Thermal Expansion in Liquids

As expansion takes place in solids so also in liquids. The expansion in liquids is a bulk affair hence we would talk of volume expansivity for liquids.

### 3.2.1 Cubical Expansion

The coefficient of volume expansion of a liquid is the fractional change in volume per the original volume for degree change in temperature. From Eq. (4.12) given below,

$$V_t = V_o (1 + \gamma \Delta\theta)$$

It is necessary to note that  $\gamma$  for liquids is not of the same order as  $3\alpha$  where  $\alpha$  is the linear expansivity of solids.

In actual fact  $\gamma$  liquids  $\approx 10 \gamma$  solid

i.e.  $\gamma$  liquids is greater than  $\gamma$  solid

The observed increase in the volume of the liquid is the difference between the expansion of the liquid and that of the container and it is therefore called relative or apparent change in volume.

For water, between  $0^\circ\text{C}$  and  $40^\circ\text{C}$  there is a decrease in volume i.e. increasing in density? But between  $4^\circ\text{C}$  and  $100^\circ\text{C}$ , the volume of water increases uniformly while its density decreases. This is what is being described as the anomalous behaviour of water. Such behaviour of water preserves the lives of marine creatures.

### 3.2.2 Real and Apparent Expansion of Liquids

Experience has shown that it is impossible to measure the real or absolute thermal expansion of a liquid by direct volume determinations. This is because liquids are contained in vessels which also expand when heated. Hence, the expansion of the content of a vessel is always relative or apparent.

Apparent expansion of the liquid is therefore less than the real expansion of the liquid. Volume dilatometers are used in the determination of thermal expansion of liquids. The mean coefficient of apparent expansion of a liquid ( $\alpha_{\text{app}}$ ) between temperature  $t_1$  and  $t_2$  is given as:

$$\alpha_{\text{app}} = \frac{V_2 - V_1}{V_1(t_2 - t_1)}$$

Where  $V_2$  is the final volume at  $t_2^\circ\text{C}$ ,  $V_1$  is the initial volume and  $(t_2 - t_1)$  the change in temperature.

This is a general definition of the coefficient of apparent expansion. It applies to such experiments as the volume dilatometer, weight thermometer, relative density bottle and sinker methods of determining the coefficient of apparent expansion.

In the last three examples, weights of the volumes of the liquid between  $t_1$  and  $t_2$  are compared which will be equal if the vessel and the sinker did not expand.

$$\alpha_{\text{app}} = \frac{\text{mass of liquid expelled}}{\text{mass remaining} \times \text{temperature change}}$$

Thus 
$$\alpha_{\text{real}} = \alpha_{\text{app}} + \gamma$$

where  $\gamma$  is the coefficient of cubical expansion of the material of vessel,  $\alpha_{\text{app}}$  is the apparent coefficient of expansion of the liquid and  $\alpha_{\text{real}}$  is the real coefficient of the liquid.

#### 4.0 CONCLUSION

When matter is heated, it expands. The ways materials expand when they are subjected to heat are described by their coefficients of expansion linear, superficial cubical expansivities.

Expansion in liquids is greater than that of solids. Besides, the study of expansion in liquids is more complicated than solids. This is because as the liquid expands, its container also expands. Thus we talk of relative expansion in liquids rather than of expansion. In the next unit we would consider the expansion in gases. This will be studied under the gas laws.

#### 5.0 SUMMARY

You have learnt the following in this unit:

- When matter is heated, it expands;
- There are three types of coefficient of expansion - linear expansivity, superficial expansivity and cubical expansivity;
- Expansion of a material depends on its nature, temperature range and the initial dimensions of the material;

- Superficial expansivity is twice the linear expansivity of solid material;
- The cubical expansivity is thrice the linear expansivity of a solid material;
- There is no absolute expansion of a liquid because it is contained in a container, which also expands.

### ANSWER SELF ASSESSMENT EXERCISE 1

Using Eq. (4.6), we get

$$A_t = A_o + \beta A_o \Delta\theta$$

$$\begin{array}{l} \text{where, } A_t = \text{area of the plate at } 40^\circ\text{C} = ? \\ A_o = \text{original area of plate} = 15\text{cm}^2 \end{array}$$

$$\begin{array}{l} \beta = 2\alpha = 2 \times 1.1 \times 10^{-5} \text{ } ^\circ\text{C}^{-1} \\ = \text{area expansivity of steel.} \end{array}$$

$$\begin{array}{l} \Delta\theta = \text{change in temperature} = (40 - 0)^\circ\text{C} \\ = 40^\circ\text{C} \end{array}$$

$$\begin{aligned} \therefore A_t &= A_o + 2\alpha A_o \Delta\theta \\ &= 15^2\text{cm}^2 + 2 \times 2 \times 1.1 \times 10^{-5} \text{ } ^\circ\text{C}^{-1} \times 40^\circ\text{C} \times 15^2\text{cm}^2 \\ &= (225\text{cm}^2 + 0.198\text{cm}^2) \\ A_t &= 225.198\text{cm}^2 \end{aligned}$$

### ANSWER SELF ASSESSMENT EXERCISE 2

Given:

$$\begin{array}{l} V_o = 5.000\text{cm}^3 \\ V_t = 5.014\text{cm}^3 \\ \text{and } t_1 = 20^\circ\text{C} \\ \text{and } t_2 = 100^\circ\text{C} \\ \therefore \Delta\theta = t_2 - t_1 = (100 - 20)^\circ\text{C} = 80^\circ\text{C} \\ \Delta V = V_t - V_o \end{array}$$

Using the Eq. (4.11)

$$\begin{aligned} \therefore \gamma &= \frac{\Delta V}{V_o \Delta\theta} \\ &= \frac{V_t - V_o}{V_o \Delta\theta} \end{aligned}$$

Substituting the values, we get

$$= \frac{(5.014 - 5.000)\text{cm}^3}{5.000\text{cm}^3 \times 80^\circ\text{C}}$$

$$= \frac{0.014}{5.000 \times 80^\circ\text{C}}$$

$$\gamma = 0.000035^\circ\text{C}^{-1}$$

$$\gamma = 3.5 \times 10^{-5}\text{C}^{-1}$$

Cubical expansivity of the metal is  $3.5 \times 10^{-5}\text{C}^{-1}$

## 6.0 TUTOR-MARKED ASSIGNMENT

1. A brass measuring scale is exactly two meters long at  $15^\circ\text{C}$ . Determine its length at  $40^\circ\text{C}$ ? ( $\alpha$  for brass =  $1.8 \times 10^{-5}\text{C}^{-1}$ ).
2. If the linear expansivity of a metal is  $2.0 \times 10^{-5}\text{C}^{-1}$ , calculate the approximate value of its superficial expansivity.
3. The density of aluminum at  $0^\circ\text{C}$  is  $2.76\text{g (cm}^{-3}\text{)}$ . Determine its density at  $200^\circ\text{C}$  (for aluminum =  $2.5 \times 10^{-5}\text{C}^{-1}$ ).

## 7.0 REFERENCES/FURTHER READING

- Awe, O. and Okunola, O. O. (1986). *Comprehensive Certificate Physics*, Ibadan: University Press Limited.
- Ference, M. (Jnr.), Lemon, H.B. and Stephenson, R. J. (1970). *Analytical Experimental Physics*, Chicago: the University of Chicago Press.
- Feynman, R. P., Leighton, R. B. and Sands, M. (1971). *The Feynman Lectures on Physics*, California: Addison – Wesley Publishing Company.
- Flowers, B. H. and Mendoza, E. (1970). *Properties of Matter*, London: John Wiley and Sons Limited.
- Noaks, M. A. (1963). *New Intermediate Physics*, Canada: Macmillan and company Limited.
- Soars, F. W., Zemansky, M.W. and Young, H. D. (1980). *College Physics*, London: Addison – Wesley Publishing Company.
- Tyler, F. (1966). *Heat and Thermodynamics*, London: Edward Arnold Publisher Limited.

Wilkinson, J. (1983). *Essentials of Physics*, Australia: McMillan Education Limited.

Zemansky, M. W., (1968). *Heat and Thermodynamics*, New York: McGraw-Hill Book Company.

## UNIT 5 GAS LAWS

### CONTENTS

- 1.0 Introduction
- 2.0 Objectives
- 3.0 Main Content
  - 3.1 Gas Laws
  - 3.2 Boyle's Law
    - 3.2.1 Experimental Proof of Boyle's Law
  - 3.3 Charles's Law
    - 3.3.1 Verification of Charles's Law
  - 3.4 Pressure Law
    - 3.4.1 Constant volume Gas Thermometer
  - 3.5 Equation of State for Ideal Gases
    - 3.5.1 Real Gases and Ideal Gases
    - 3.5.2 Absolute Zero and Absolute Temperature
    - 3.5.3 Universal Gas Constant
    - 3.5.5 Real Gas Equation
- 4.0 Conclusion
- 5.0 Summary
- 6.0 Tutor-Marked Assignment
- 7.0 References/Further Reading

### 1.0 INTRODUCTION

When solids and liquids are heated, they are not significantly affected by changes in pressure as their temperatures change. This is why we did not consider the effect of pressure during the expansion of solids and liquids. However, for a given mass of gas, the expansion of a gas is considerably affected by pressure. It is to be noted that in describing the behaviour of gases, when subjected to heat, four variables are usually considered.

They are:

- pressure (P)
- volume (V)
- temperature (T) and
- the number of moles (n) of the gases.

These four properties or parameters are used to describe the state of a given mass of a gas. In this unit, we shall first discuss the relationship between the temperature, pressure and volume of a gas. Then we will examine the behaviour of gases using these parameters to deduce the various gas laws.



## 2.0 OBJECTIVES

At the end of this unit, you should be able to:

- state the different gas laws
- explain the gas laws through the use of graphs
- distinguish between a real gas and an ideal gas
- express the equation of state of an ideal gas
- solve problems on these gas laws.

## 3.0 MAIN CONTENT

### 3.1 GAS LAWS

You will recall that four properties are used to describe the behaviour of gases; namely:

Pressure (P), Volume (V), Temperature (T), and Amount of the gas in moles (n).

When any two of these properties are kept constant, the other two are then subjected to change in order to show how the gas behaves. The first two will be considered while temperature and the number of moles of the gas is kept constant.

### 3.2 Boyle's Law

Boyle (1662) investigated the relationship between the pressure (P) and the volume (V) of a given mass of gas when the temperature (T) and the number of moles (n) are kept constant. Boyle's law states that:

**“The pressure on a given mass of gas is inversely proportional to its volume (V) provided its temperature is kept constant”.**

Symbolically, this statement is written as:

$$P \propto \frac{1}{V} \dots\dots\dots (5.1)$$

$$\therefore P = \frac{K}{V} \text{ where, K is a constant of proportionality.}$$

$$\therefore PV = K = \text{Constant} \dots\dots\dots (5.2)$$

If you plot a graph P versus  $\frac{1}{V}$ , then the graph would be as given below in fig. 5.1(i) and fig. 5.1(ii).

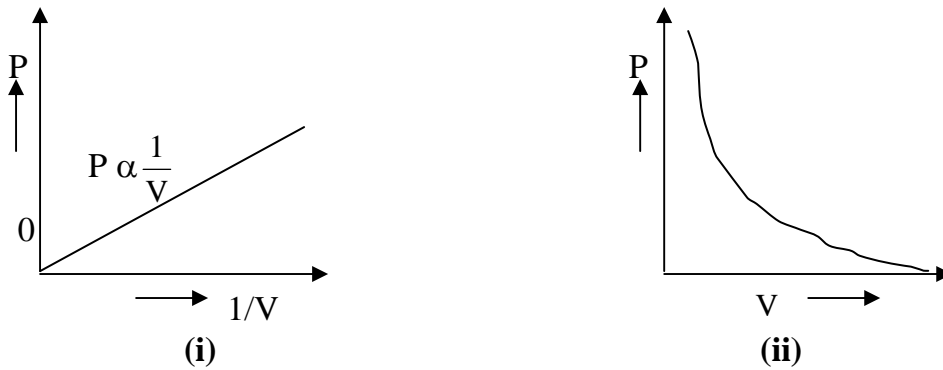


Fig. 5.

### 3.2.1 Experimental Proof of Boyle's Law

Boyle's law may be demonstrated by using a 'J' tube as shown in fig. 5.2 such that one end is opened and the other end closed. Thus AB in fig. 5.2 contains the trapped air by the column of mercury. The mercury head (h) constitutes the pressure on the trapped air in addition to the pressure due to the atmosphere ( $H_0$ ). The cross sectional area of the 'J' tube is assumed to be uniform. That is, the circular area is uniform.

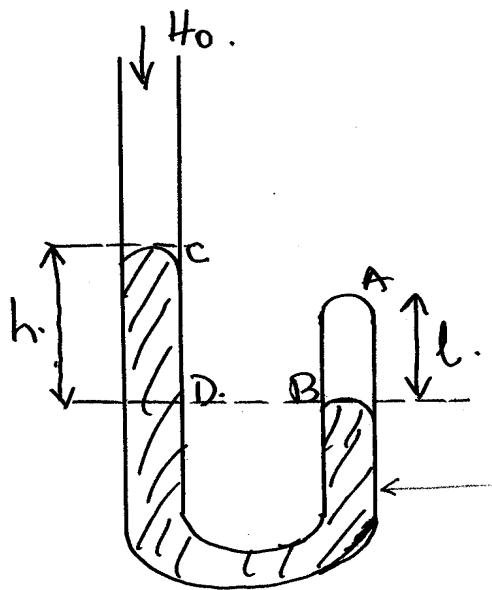


Fig. 5.2

You would have noticed that two variables can be identified in this set up.

- (i) the volume of the air trapped  $V = A\ell$ .....(5.3)  
 where A is the area of cross-section of the tube and  $\ell$  is the length of the air trapped.

- (ii) the pressure  $P$  on the tapped air which is made up of the atmospheric pressure  $H_0$  and the mercury column  $h$ .

From Eq. (5.3),

$V = A \ell$  we say that Volume ( $V$ ) is proportional to the length of the air.

$$\therefore V \propto \ell \text{ and } \frac{1}{V} \propto \frac{1}{\ell} \dots\dots\dots (5.4)$$

Thus the measurement of  $\ell$  is proportional to  $V$

As you know, the pressure =  $h\rho g$

Where,  $h$  is the height of the mercury column,  $\rho$  is the density of mercury, and  $g$  is the acceleration due to gravity.

$\rho$  and  $g$  are constants.

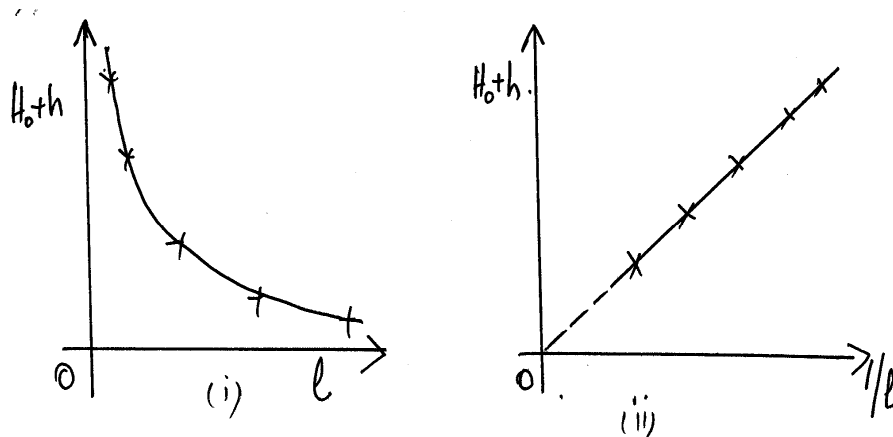
This also means that the pressure  $P$  on the gas is proportional to the height ( $h$ ) of the mercury.

$$P \propto h$$

That is the total pressure on the gas  $P \propto (H_0 + h)$  where  $H_0$  is the barometric height – atmospheric pressure and  $h$  is the mercury head in the ‘J’ tube.

Thus the measurement of  $H_0 + h$  will be proportional to the pressure  $P$ . Pouring more mercury through the open end varies the length  $\ell$  of the air column. For each measured height  $h$  of the mercury, the corresponding length  $\ell$  of the air column is measured.

First, we then plot the graph of  $(H_0 + h)$  against  $\ell$  with the  $(H_0 + h)$  on the vertical axis and  $\ell$  on the horizontal axis. We would obtain a graph as shown in fig. 5.3(i). This shows that as  $(H_0 + h)$  increases,  $\ell$  decreases.



**Fig. 5.3:** (i) Plot of  $(H_0 + h)$  versus  $l$  (ii) Plot of  $(H_0 + h)$  versus  $(\frac{1}{l})$

Secondly, if we plot the graph of  $(H_0 + h)$  against  $\frac{1}{l}$ , with  $(H_0 + h)$  on the vertical axis and  $\frac{1}{l}$  on the horizontal axis. A graph as shown in fig. 5.3 (ii) will be obtained. We find that the plot is a linear graph.

The two graphs are in consonance with Boyle’s law. Fig. 5.3(i) says that as the pressure increases, the volume decreases while fig. 5.3(ii) is also saying that the pressure is inversely proportional to the volume of the gas.

$$(H_0 + h) \propto \frac{1}{l} \dots\dots\dots (5.5)$$

or

$$P \propto \frac{1}{V}$$

$$P = \frac{K}{V}$$

$$\therefore PV = K$$

Thus for volume  $V_1$  and pressure  $P_1$ ,  $P_1V_1 = k$  and for volume  $V_2$  and pressure  $P_2$ ,  $P_2V_2 = K$

The meaning of these statements is that when an amount of a gas ( $n$ ) and its temperature  $t$  are kept constant we can conveniently state that

$$P_1V_1 = P_2V_2 = K \dots\dots\dots (5.6)$$

However, if n changes then

$$P_1V_1 \neq P_2V_2 \dots\dots\dots (5.7)$$

and the conditions of the experiment are no longer consistent with the conditions of the law even when the temperature is kept constant.

Boyle’s law is applied in air compressors and exhaust (vacuum) pumps.

**SELF ASSESSMENT EXERCISE 1**

Under a Pressure of  $14\text{Nm}^{-2}$ , some air has a volume of  $1.5\text{m}^3$ . Determine its volume when its pressure is  $10\text{Nm}^{-2}$ . Assuming the temperature is kept constant.

**3.3 Charles’s Law**

Charles’s law deals with the behaviour of a given mass of gas at constant pressure. Under this law, we would consider the variation of volume (V) with temperature (T) when the pressure (P) and the amount of the gas (n) are kept constant.

The original Charles’s state that:

**“At constant pressure, the volume of a given amount of gas increases by a constant fraction of its volume at 0°C for each Celsius degree rise in temperature”.**

The Mathematical expression for this can be written as:

$$V \propto T \text{ (at constant n and P) } \dots\dots\dots (5.8)$$

The above statement brings out the idea of volume coefficient, r, where r is defined as the increase in volume of a unit volume of the gas at 0°C for each degree Celsius rise in temperature when the fixed mass of that gas is heated at constant pressure.

The volume coefficient is called volume expansivity. For more detail, you can see the unit 4, section 3.1.4.

If  $V_0$  is the volume of the gas at 0°C and  $V_t$  is the volume of the gas at t°C, then r is expressed as:

$$r = \frac{\Delta V}{V_0 \Delta \theta}$$

$$\begin{aligned}
 &= \frac{V_t - V_o}{V_o(t - 0)} \\
 \therefore r &= \frac{V_t - V_o}{V_o t} \\
 \therefore \begin{aligned} V_t &= V_o + r V_o t \\ V_t &= V_o (1 + rt) \dots\dots\dots (5.9) \end{aligned}
 \end{aligned}$$

Note that  $V_o$  stands for the volume of the gas at  $0^\circ\text{C}$  and not just the original volume at any selected initial temperature. And that  $t$  is the actual temperature using the Celsius scale and not for any selected temperature rise.

The value of  $r$  for most gases is  $\left(\frac{1}{273}\right)$ . Now substituting the value of  $r$  in Eq. (5.9), we get

$$V_t = V_o \left(\frac{273+t}{273}\right) \dots\dots\dots 5.10$$

But as you know from the absolute scale,

$$\left. \begin{aligned} (273 + t) &= T\# \text{ and that} \\ 273 &= T_o \end{aligned} \right\} \dots\dots\dots (5.11)$$

Then putting the values in Eq. (5.11) into Eq. (5.10), we get

$$\therefore V_t = \frac{V_o T}{T_o}$$

On rearranging the terms, we obtain

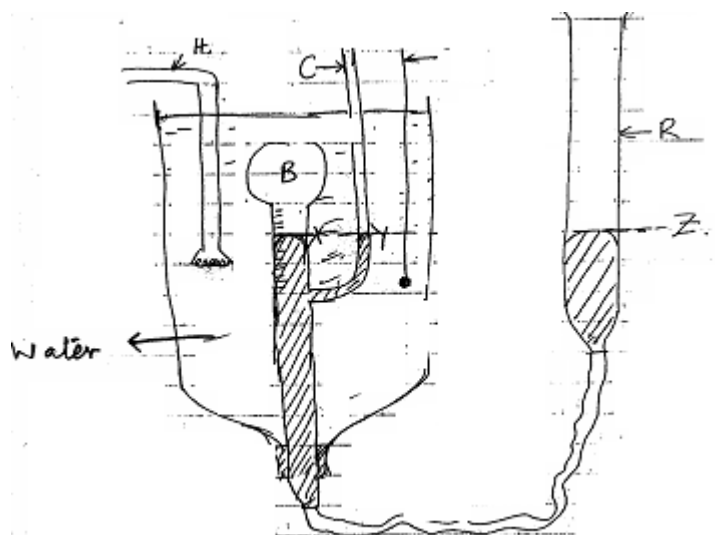
$$\therefore \frac{V_t}{T} = \frac{V_o}{T_o} = \text{Constant}$$

$$\therefore V_t = K\# \quad \text{i.e. } V_t \propto T$$

Thus the volume of the gas ( $V$ ) is directly proportional to its absolute temperature ( $T$ ). The equation  $V_t = KT$  is a deduction, or consequence of Charles's law. It is not the law.

### 3.3.1 Verification of Charles's Law

We shall describe here, the experimental procedure for the determination of the coefficient of volume expansion of a gas. The experimental set up is as shown in fig. 5.4 below:



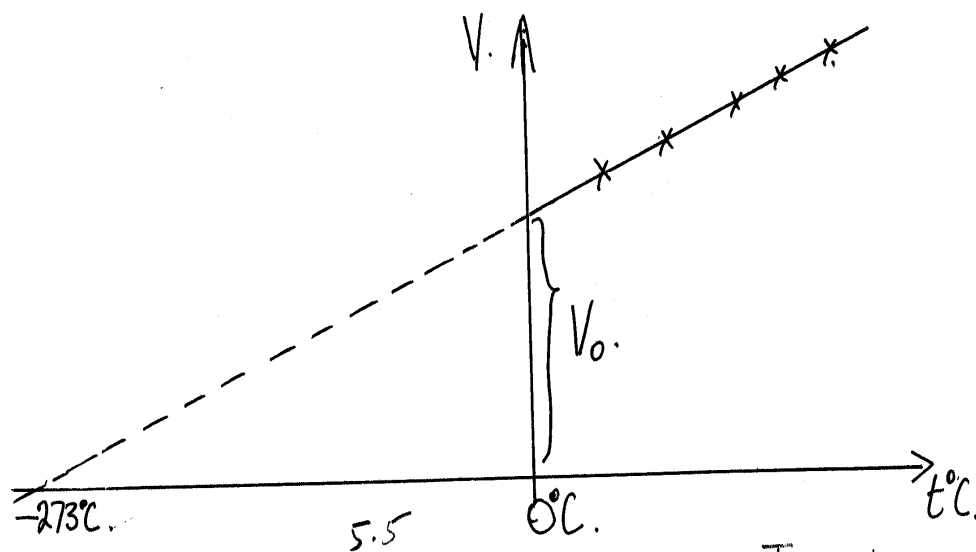
**Fig. 5.4: Charles's Law Apparatus**

The apparatus is made up of a glass bulb B filled with dry air. The bulb is continuous with a graduated tube. The mercury column encloses the dry air. A branch tube C is also connected to the graduated bulb B that is open to the atmosphere. The mercury levels X in bulb B and Y in tube C are adjusted to be the same. Raising or lowering the reservoir R adjusts Z in tube C to the same level. In that case the pressure on the gas is the same as that of the atmosphere pressure.

The bulb B and tube C are surrounded by a water bath, which contains an electric heater H, which is also used as a stirrer. A thermometer T is inserted to measure the temperature of the bath. The initial volume  $V_1$  and the initial temperature  $t_1$  of the gas in the bulb are measured. The temperature of the gas is the same as that of the water in the bath. They are both recorded when the level X, Y and Z have been adjusted to be the same.

The heater is then switched on until there is a difference of 20°C rise in temperature. It is then switched off and used to stir the water thoroughly. The level X, Y and Z are then adjusted again to obtain a new volume  $V_2$  and its new corresponding temperature  $t_2$ °C. The above procedure is repeated for another set of five or six volume measurements between the room temperature  $t_2$ °C and 100°C.

When then plot the graph of volumes  $V$  on the vertical axis against their corresponding temperature  $t$  on the horizontal axis. A linear graph as shown in fig. 5.5 is obtained.



**Fig. 5.5:** A graph of Volume versus Temperature

The volume at  $0^{\circ}\text{C}$ ,  $V_0$  may be extrapolated so that  $r$ , the volume coefficient could be determined.

$$r = \frac{V_t - V_0}{V_0 \times t}$$

Further extrapolation of the graph enables us to determine the absolute zero temperature. This is found to be  $-273^{\circ}\text{C}$ . In conclusion, the coefficient of the volume expansion (volume expansivity) will be found to be 0.003663, which is approximately equal to  $\frac{1}{273}$ .

Using the absolute scale temperature, it will be observed from the graph

that  $\frac{V}{T} = \text{Constant}$ .

$$\therefore \frac{V_1}{T_1} = \frac{V_2}{T_2}$$

***Thus, the volume of a given mass of gas is directly proportional to its absolute temperature provided the pressure is kept constant – another form of Charles's law.***



**SELF ASSESSMENT EXERCISE 2**

Some hydrogen gas a volume of  $200\text{cm}^3$  at  $15^\circ\text{C}$ . If the pressure remains constant, at what temperature will its volume be  $150\text{cm}^3$ ?

**3.4 Pressure Law**

In this section we shall once again examine the behaviour of a gas by observing how its pressure (**P**) varies with temperature (**t**), when its volume (**V**) and the amount of the gas (**n**) are kept constant. The study under this section is described as pressure law or Gay-Lussac's law.

It will be observed that the law of increase with increase in temperature at constant volume is the same as the law of increase in volume with increase in temperature at constant pressure provided there is no change in the amount of the gas.

The pressure law states that:

**“For a given mass of a gas at constant volume, its pressure increases by a constant fraction of pressure at  $0^\circ\text{C}$  for each Celsius degree rise in temperature”.**

Let us consider a fixed mass of gas of volume  $V_1$  at  $t_1^\circ\text{C}$  and pressure  $P_1$ .

Suppose the gas is then heated to some temperature  $t_2^\circ\text{C}$  at which the volume is  $zV_1$ . Where  $z$  is a fraction.

We can reduce this new volume  $zV_1$  to  $V_1$  at higher temperature by increasing the pressure to. Using Boyle's law.

$$\begin{aligned} P_2 V_1 &= P_1 z V_1 \\ \therefore P_2 &= z P_1 \end{aligned}$$

Thus, when the temperature is raised, the volume can be maintained at  $V_1$  by increasing the pressure. That is, the rise in temperature, which causes an increase in volume from  $V_1$  to  $zV_1$  if the pressure is kept at  $P_1$ , also causes an increase in pressure from  $P_1$  to  $zP_1$  if the volume is kept constant at  $V_1$ . If Boyle's law is not obeyed perfectly then the theoretical basis fails.

However, experiment have shown that when a fixed mass of gas is heated at constant volume, its pressure increase s by a constant fraction of the pressure at  $0^\circ\text{C}$  for each degree Celsius rise in temperature.

The above statement thus defines the pressure coefficient  $\beta$  or pressure expansivity.

The pressure coefficient  $\beta$  is defined as the increase in pressure expressed as a fraction of the pressure at 0°C for one Celsius degree rise in temperature when a fixed mass of that gas is heated at constant volume.

If  $P_0$  is the pressure of the gas at 0°C and  $P_t$ , the pressure at  $t^\circ\text{C}$ , then is defined as:

$$\beta = \frac{\Delta P}{P_0 t}$$

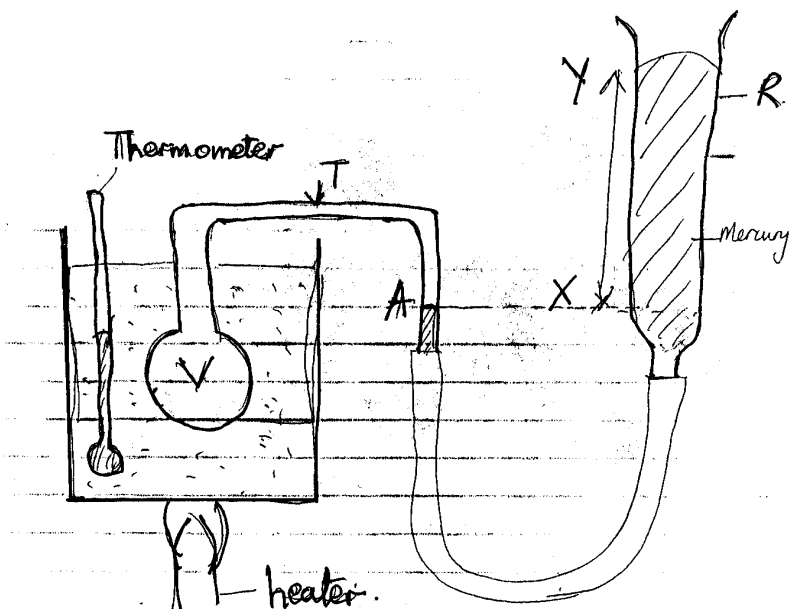
$$\therefore \beta = \frac{P_t - P_0}{P_0 t}$$

$$\therefore P_t - P_0 = \beta P_0 t$$

$$\therefore P_t = P_0 (1 + \beta t) \dots\dots\dots (5.13)$$

### 3.4.1 Constant volume Gas Thermometer

Jolly's constant volume air thermometer is used to determine the pressure coefficient  $\beta$  for a gas (fig. 5.6).



**Fig. 5.6: Constant Volume Air Thermometer**

It consists of a glass bulb V of volume 10cm filled with dry air. The bulb V is connected to a glass capillary tube T that in turn is connected

to a mercury manometer R which measures pressure. A fixed reference mark is made on the capillary tube at A.

The moveable arm of the manometer R is usually adjusted up and down as may be necessary to ensure that the mercury level at A remains the same. This marks the constant volume before any reading is taken.

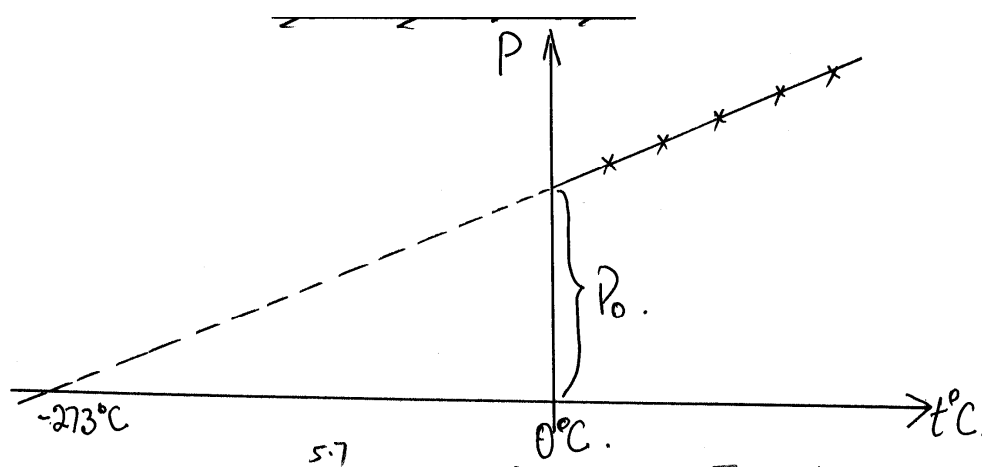
The initial pressure of the gas at the room temperature is noted from the difference in the mercury levels at X and Y. This is done by arranging the bulb in a water bath, which is well stirred, and with the mercury thermometer in the water bath. The room temperature is taken as the temperature of the water bath on which the thermometer is inserted.

The pressure of the atmosphere is read first from the barometer. Then the initial temperature of the water bath is taken. When the mercury level is first brought to level A the level Y is noted. The difference between Y and X given the mercury head, h.

Thus, the total pressure on the volume of gas is

$$P \propto (H + h)\text{cm of mercury.}$$

The water bath is gently heated through, about  $20^{\circ}\text{C}$  when the heating is stopped and stirred thoroughly. The moveable arm of the manometer is adjusted, the mercury level A at a steady temperature to enable the reading of anew level of Y. The new temperature is taken and the new corresponding pressure head h is measured. The above procedure is repeated for a set of five or six readings. The barometric height is read again as a check at the end of the experiment. The graph of pressure readings is plotted against the corresponding values of the temperature readings. The graph is shown in fig. 5.7.



**Fig. 5.7: Graph of Pressure versus Temperature**

Our conclusion from this graph is that the pressure on the gas varies linearly with the temperature. When the graph is extrapolated, the pressure  $P_0$  at  $0^\circ\text{C}$  can be read from the graph. Further extrapolation produces the absolute temperature which will be found to be approximately equal to  $-273^\circ\text{C}$ .

The slope of the graph  $\beta = \frac{\Delta P}{P_0 t}$

$$\therefore \beta = \frac{P_t - P_0}{P_0 t} = \frac{1}{273} \dots\dots\dots (5.14)$$

The following precautions are usually taken:

- the mercury level is changed gradually;
- the volume is maintained at constant value at A;

Sources of error could also be found in:

- the dead space of the capillary tube T and
- the expansion of the bulb which also introduces error.

If  $\beta = \frac{1}{273}$

From,  $\beta = \frac{\Delta P}{P_0 t}$

$$\therefore \beta = \frac{P_t - P_0}{P_0 t}$$

$$\therefore P_t - P_0 = \beta P_0 t$$

$$\therefore P_t = P_0 + \beta P_0 t$$

$$P_t = P_0 (1 + \beta t) \dots\dots\dots (5.15)$$

Put  $\beta = \frac{1}{273}$  in Eq. (5.15), we get

$$= P_0 \left( 1 + \frac{1}{273} t \right)$$

$$P_t = P_0 \left( \frac{273 + t}{273} \right) \dots\dots\dots (5.16)$$

Using the absolute scale of temperature,

$$273 + t = T$$

$$\therefore P_t = \frac{P_0}{273} \times T$$

$$\begin{aligned}
 &= \frac{P_o T}{T_o} \\
 \therefore \frac{P}{T} &= \frac{P_o}{T_o} = K \dots\dots\dots (5.17) \\
 \therefore P_t &= KT
 \end{aligned}$$

Hence,  $P_t \propto T \dots\dots\dots (5.18)$

This means that the pressure of the gas is directly proportional to its absolute temperature provided the volume is kept constant. This is another consequence of the pressure law. The original law states that

That is for a fixed mass of any gas heated at constant volume, the pressure increase by  $\frac{1}{273}$  of the pressure at 0°C for each Celsius degree rise in temperature. Whereas,  $\frac{P}{T} = \text{constant}$  is the deduction or the consequence from the law. It states that the pressure of a given mass of gas is directly proportional to its absolute temperature.

**SELF ASSESSMENT EXERCISE 3**

The pressure in a diver’s oxygen cylinder is  $1.25 \times 10^6 \frac{N}{m^2}$  at 20°C. Determine the pressure in the cylinder if it is lowered into water at 10°C

**3.5 Equation of State for Ideal Gases**

In physics, two kinds of gases are usually discussed. They are real gases and ideal gases. You may like to know the difference between an ideal gas and a real gas. We shall now describe the properties of real gases and ideal gases.

**3.5.1 Real Gases and Ideal Gases**

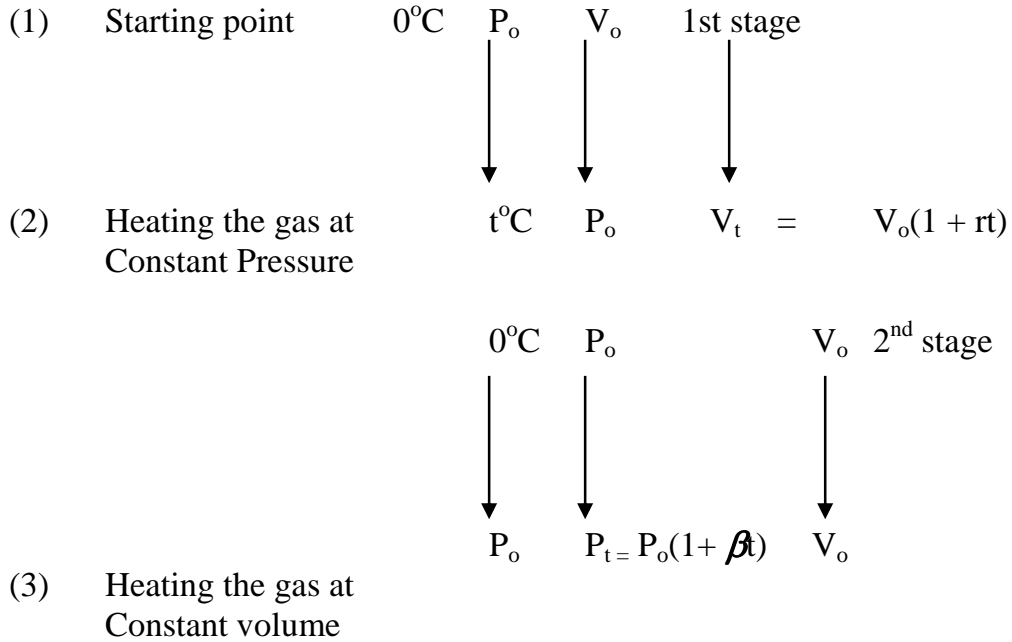
At extremely low pressure, all gases closely obey Boyle’s law. Thus if Boyle’s law is obeyed, the volume coefficient  $\alpha$  and the pressure coefficient  $\beta$  are the same for the same gas.

Starting with a fixed mass of a gas at 10°C at pressure  $P_o$  and volume  $V_o$ , we then heat to a temperature of  $t^\circ\text{C}$  in two ways.

Firstly, we heat at constant pressure, then cool it down again to 0°C and then repeat the process at constant volume.

(i) at constant pressure  $P_o$  the volume changes to  $V_t$  when heated to

$$\therefore \begin{matrix} \text{temperature} \\ V_t \end{matrix} = \begin{matrix} t^\circ\text{C} \\ V_o(1 + rt) \end{matrix}$$



At constant pressure the product  $PV = P_oV_o(1 + rt) \dots\dots\dots (5.19)$

(ii) At constant volume  $V_o$ , the pressure becomes  $p_t = P_o(1 + \beta t)$   
 The product  $PV$  then becomes  $P_oV_o(1 + \beta t) \dots\dots\dots (5.20)$

If Boyle’s law is obeyed, all values of the product  $PV$  at the same temperature  $t^\circ\text{C}$  must be the same.

$$\therefore P_oV_o(1 + rt) = P_oV_o(1 + \beta t) \dots\dots\dots (5.21)$$

Hence  $r = \beta$

By plotting the values of  $r$  and  $\beta$  against pressure  $P$ , a graph shown in fig. 5.8 will be obtained.

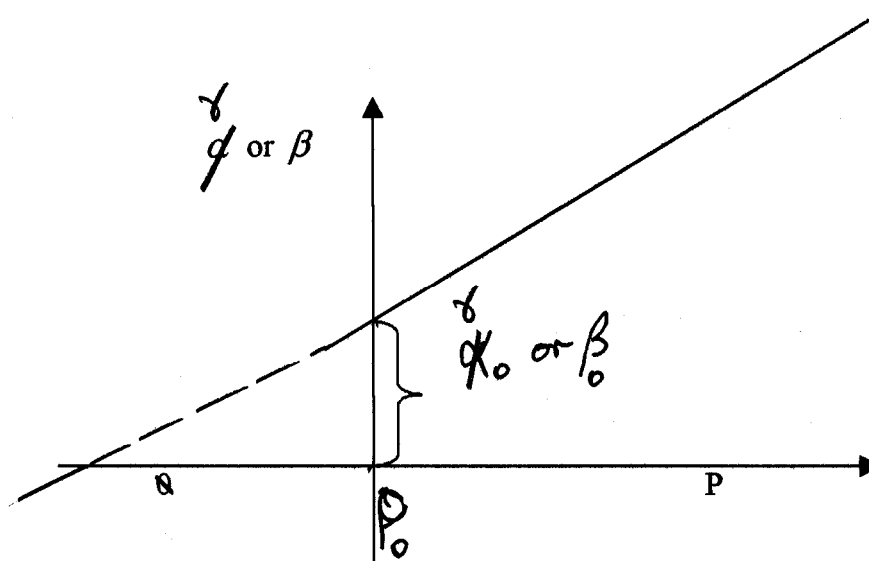


Fig. 5.8

By extrapolating to zero pressure, the pressure values of these coefficients at limiting conditions when Boyle's law is obeyed are found to be closely the same. (Table 5.1).

Table 5.1

Gas	$r$	$\beta$
Helium	0.0036607	0.0036609
Hydrogen	0.0036611	0.0036610
Nitrogen	0.0036609	0.0036606

The table 5.1 shows that the pressure coefficient and the volume coefficient for each individual gas are very close to one another. Also the values for different gases are all close to the mean values of 0.0036608. Hence in the limiting case at extremely low density and pressure, when Boyle's law is obeyed closely, all gases have the same volume coefficient 0.036608 and the same pressure coefficient 0.0036608.

Real gases will behave in this way only at extremely low pressures. This behaviour is what is described as being ideal.

A gas, which would behave in this way at all pressure, is called an ideal or perfect gas. In practice real gases are not ideal but we consider some approximations to ideal gas under some specified conditions.

We are now in the position to produce the equation of state for an ideal gas. At constant pressure,

$$PV = P_0V_0(1 + \alpha t) \dots\dots\dots (5.22)$$

At constant pressure,

$$PV = P_0V_0(1 + \beta t) \dots\dots\dots (5.23)$$

$$\text{But } \alpha = \beta = 0.0036608 = \frac{1}{273} \text{ (nearly)}$$

$$\text{Thus } PV = P_0V_0 \left( 1 + \frac{1}{273} t \right) \dots\dots\dots (5.24)$$

$$= P_0V_0 \left( \frac{273 + t}{273} \right)$$

$$\text{where } T_0 = 273 \text{ and } 273 + t = T$$

$$\therefore PV = \left( \frac{P_0V_0}{T_0} T \right) \dots\dots\dots (5.25)$$

$$\therefore \frac{PV}{T} = \left( \frac{P_0V_0}{T_0} \right) = K = \text{Constant} \dots\dots\dots (5.26)$$

For a given mass of gas  $PV = KT$

This is the equation of state for ideal gases.

### 3.5.2 Absolute Zero and Absolute Temperature

From the equation of state of an ideal gas we obtained,

$$PV = \frac{P_0V_0}{T_0}(273 + t)$$

$$\therefore PV = K(273 + t)$$



If the graph of  $PV$  is then plotted against temperature  $t$  for a perfect gas, a graph as shown in fig. 5.9 is obtained.

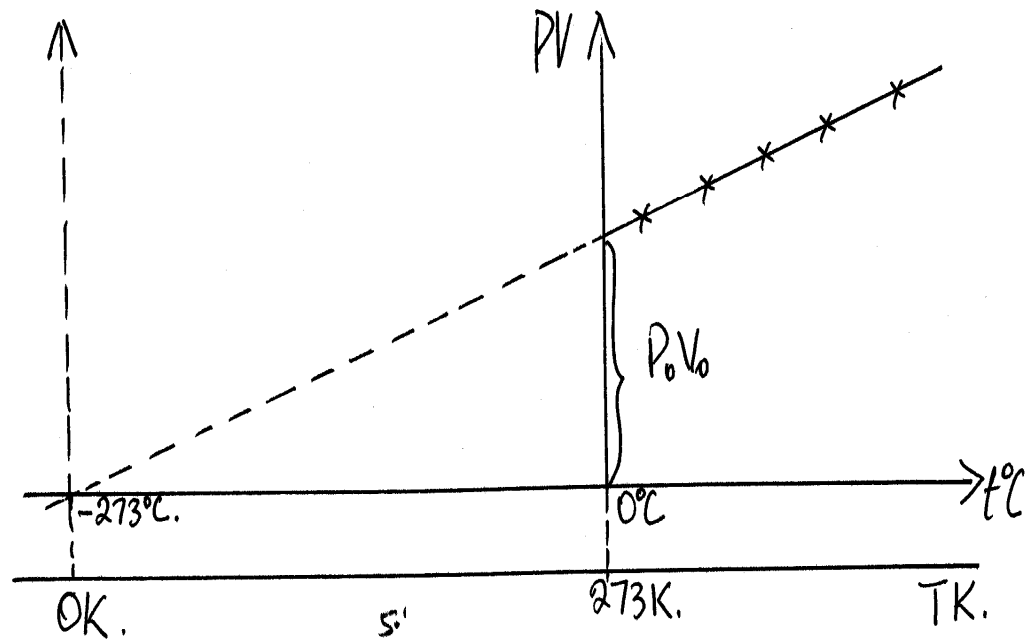


Fig. 5.9

The product  $PV$  has a value of zero when the temperature  $t$  is  $-273^{\circ}\text{C}$ . At this point the product  $PV$  for a perfect gas would vanish completely. The point  $Z$  is therefore referred to as the absolute zero of temperature. If the origin of the graph  $0$  is now transferred to  $Z$ , then the new scale is denoted by  $T$ . This is what is referred to as the absolute scale of temperature, the SI unit of which is Kelvin. You will notice that both the Celsius scale and the Absolute scale are related in such a way that

$$T = (273 + t)\text{K}$$

The unit of  $T$  is Kelvin while that of  $t$  is degree Celsius ( $^{\circ}\text{C}$ ).

### 3.5.3 Universal gas Constant

From the Eq. (5.27)  $PV = KT$

where 
$$K = \frac{P_0 V_0}{273} = \frac{P_0 V_0}{T_0}$$

The pressure  $P_0$  and  $273$  ( $T_0$ ) fix the density of the gas when the volume  $V_0$  is proportional to the mass of the gas considered. Therefore  $K$  varies directly as the mass of the gas  $K$  is constant in the sense that it has a fixed value for a given mass of an ideal gas.

There are two kinds of units of mass: the gramme and the mole (the gramme molecular weight) – gramme – mole. If you consider one mole of a gas, R replaces the constant K.

$$\therefore PV = RT$$

Hence the equation  $PV = RT$  is the ideal gas equation for one mole of the gas. Generally for n mole of a gas we would write:

$$PV = nRT \dots\dots\dots (5.28)$$

Where n = molar fraction  
 R is the Universal gas constant for a mole of a gas.

It has been experimentally found that under standard temperature (273K) and pressure (76mm of Hg) one mole of gas occupies approximately 22.4 litres.

$$\begin{aligned} 1 \text{ litre} &= 1000\text{cm}^3 \\ 1 \text{ cm}^3 &= 10^{-6}\text{m}^3 \\ \therefore 1000\text{cm}^3 &= 1000 \times 10^{-6}\text{m}^3 \\ \therefore 22.4 \text{ litres} &= 22.4 \times 10^{-3}\text{m}^3 \end{aligned}$$

The number of molecules in a mole of nay gas is

$$6.03 \times 10^{23} = N = \text{Avogadro's number.}$$

If m is the mass of gas in gramme and M is the molecular weight of the gas, the number of moles of the gas is given as:

$$n = \frac{m}{M} \dots\dots\dots (5.29)$$

$$\therefore PV = \frac{mRT}{M} \dots\dots\dots (5.30)$$

**The value of R for 1 mole of a gas**

Let P be the pressure on the gas = 76cm of Hg = standard pressure.

$$\begin{aligned} \text{Put } P &= h\rho g \\ &= \frac{76}{100} \text{ m} \times 13600 \frac{\text{kg}}{\text{m}^3} \times 9.8 \frac{\text{m}}{\text{s}^2} \\ &= 1.0129 \times 10^5 \text{Nm}^{-2} \end{aligned}$$

For a standard temperature  $T = 273\text{K}$  and standard volume  $V = 22.4$  litres or  $22.4 \times 10^{-3}\text{m}^3$  and for one mole of the gas,  $R$  can be obtained by using the Eq. (5.28). The value of  $R$

$$\begin{aligned}
 PV &= nRT \\
 \therefore R &= \frac{PV}{nT} \quad \text{where } n = 1 \\
 &= \frac{1.0129 \times 10^5 \frac{\text{N}}{\text{m}^2} \times 22.4 \times 10^{-3} \text{m}^3}{1 \text{ mole} \times 273\text{K}} \\
 \therefore R &= \frac{1.0129 \times 10^5 \times 22.4 \times 10^{-3}}{273} \frac{\text{N} \cdot \text{m}}{\text{mole} \cdot \text{K}} \\
 &= 8.31 \frac{\text{J}}{\text{mole} \cdot \text{K}}
 \end{aligned}$$

$R = 8.31 \text{ J mole}^{-1} \text{ K}^{-1}$  is the molar gas constant and it is the same for all gases.

#### SELF ASSESSMENT EXERCISE 4

Some hydrogen collected at  $25^\circ\text{C}$  and  $740\text{mmHg}$  has a volume of  $550\text{cm}^3$ . What will be its volume at standard temperature and pressure (s.t.p.) i.e.  $0^\circ\text{C}$  and  $760\text{mmHg}$ ?

#### 3.5.5 Real Gas Equation

An ideal gas will obey Boyle's law at any temperature. However, real gases such as air, oxygen, nitrogen and other permanent gases will obey Boyle's law within less than one part in a thousand at ordinary pressures and temperatures. At higher pressures and lower temperature, the deviations are more pronounced. In other words, the relation  $PV$  is no longer valid.

Kinetic theory of gases suggest that Boyle's law should be obeyed if the molecules are themselves infinitesimally small and if they do not attract each other at all. These assumptions are not true for any real gas. Thus  $PV = nRT$  cannot be used for real gases.

In order to account for the difference between the behaviour of a gas and that of an ideal gas, we have to allow for the molecular attractions which converts the pressure  $P$  to  $(P + \chi)$  and the finite volume occupies by the molecules which reduces the volume  $V$  of the gas to  $(V - \gamma)$ . These corrections therefore enable us to re-express  $PV = nRT$  as:

$$(P + \chi)(V - \gamma) = nRT \dots\dots\dots (5.31)$$

We therefore need to find suitable expressions for  $\chi$  and  $\gamma$ .

It was Van der Waal (1910) a Dutch Professor of Physics who found these expression to be  $\chi = \frac{a}{V^2}$  and  $\gamma = b$  ..... (5.32)

Where, a and b are constants for a unit mass of a gas under consideration.

Consequently substituting the values of Eq. (5.32) in Eq. (5.31), we now have the equation:

$$\left(P + \frac{a}{V^2}\right)(V - b) = nRT \text{ ..... (5.33)}$$

This is the Van der Waal's equation of state for real gases. It is therefore known as the real equation of state.

#### 4.0 CONCLUSION

In this unit, the three gas laws: Boyle's, Charles's and the Pressure laws have been established. We did this by observing the behaviour of the gas by using the following properties – pressure, volume, temperature and the amount of the gas in moles. Any two of these properties are held constant while we study the variation of the remaining two properties. The equation of state was also stated as  $PV = nRT$ .

Further more, we established what real and ideal gases are. We also showed how van der Waal's equation of state was used to correct for the interactive forces, which affect the pressure and the volume occupied by the molecules, which corrects for the volume of the gas. This was given as:

$$\left(P + \frac{a}{V^2}\right)(V - b) = nRT$$

#### 5.0 SUMMARY

In this unit, you have learnt about:

- The gas laws such as:
  - (i) Boyle's law ( $PV = \text{constant}$ )
  - (ii) Charles's law ( $\frac{V}{T} = \text{constant}$ )

(iii) Pressure law ( $\frac{P}{T} = \text{constant}$ )

- The three laws were combined to form the equation of state for ideal gases, which is  $PV = nRT$ .
- Pressure, volume, temperature and the amount of the gas in moles have been used to describe the behaviour of gases.
- The equation of state for real gases is  $\left(P + \frac{a}{V^2}\right)(V - b) = nRT$ .

### ANSWER SELF ASSESSMENT EXERCISE 1

#### First Condition

$$\begin{aligned} P_1 &= 14\text{Nm}^{-2} \\ V_1 &= 1.5\text{m}^3 \end{aligned}$$

#### Second Condition

$$\begin{aligned} P_2 &= 10\text{Nm}^{-2} \\ V_2 &= ? \text{ (to be found)} \end{aligned}$$

Using Boyle's law, Eq. (5.6)

$$\therefore V_2 = \frac{P_1 V_1}{P_2}$$

$$V_2 = \frac{14 \frac{\text{N}}{\text{m}^2} \times 1.5\text{m}^3}{10 \frac{\text{N}}{\text{m}^2}}$$

We get,

$$V_2 = 2.1\text{m}^3$$

**Volume of the gas at  $10\text{Nm}^{-2}$  is  $2.1\text{m}^3$**

### ANSWER SELF ASSESSMENT EXERCISE 2

$$\begin{aligned} V_1 &= 200\text{cm}^3 && \text{(given)} \\ T_1 &= 15^\circ\text{C} = (273 + 15)\text{K} && \text{(given) = 288K} \\ V_2 &= 150\text{cm}^3 \\ T_2 &= ? \end{aligned}$$

Using Charles's law Eq. (5.12),

$$\begin{aligned} \therefore \frac{V_1}{T_1} &= \frac{V_2}{T_2} = \text{Constant} \\ \therefore T_2 &= \frac{V_2 T_1}{V_1} \\ &= \frac{150\text{cm}^3 \times 288\text{K}}{200\text{cm}^3} \\ T_2 &= 216\text{K} = 273 + t \\ \therefore t &= 216 - 273 \\ \mathbf{t} &= \mathbf{-57^\circ\text{C}} \end{aligned}$$

### ANSWER SELF ASSESSMENT EXERCISE 3

$$\begin{aligned} P_1 &= 1.25 \times 10^6 \text{Nm}^{-2} \\ T_1 &= 20^\circ\text{C} = (273 + 20)\text{K} = 293\text{K} \\ P_2 &= ? \\ T_2 &= 15^\circ\text{C} = (273 + 10)\text{K} = 283\text{K} \end{aligned}$$

Using the pressure law:

$$\begin{aligned} \frac{P_1}{T_1} &= \frac{P_2}{T_2} \\ \therefore P_2 &= \frac{P_1 T_2}{T_1} \\ &= \frac{1.25 \times 10^6 \frac{\text{N}}{\text{m}^2} \times 283\text{K}}{293\text{K}} \\ &= \mathbf{1.21 \times 10^6 \text{Nm}^{-2}} \end{aligned}$$

### ANSWER SELF ASSESSMENT EXERCISE 4

$$\begin{aligned} P_1 &= 740\text{mmHg} \\ V_1 &= 550\text{cm}^3 \\ T_1 &= 25^\circ\text{C} = (273 + 25)\text{K} \\ &= 298\text{K} \\ P_2 &= 740\text{mmHg} \\ V_2 &= ? \\ T_2 &= 0^\circ\text{C} = 273\text{K} \end{aligned}$$

Using the Eq. given below, we get

$$\begin{aligned} \frac{P_1 V_1}{T_1} &= \frac{P_2 V_2}{T_2} \\ \therefore V_2 &= \frac{P_1 V_1 T_2}{P_2 T_1} \\ &= \frac{740\text{mmHg} \times 550\text{cm}^3 \times 273\text{K}}{760\text{mmHg} \times 298\text{K}} \\ &= \mathbf{490.60\text{cm}^3} \end{aligned}$$

## 6.0 TUTOR-MARKED ASSIGNMENT

1. The density of some air at a pressure of 7720mmHg is  $1.26\text{kgm}^{-3}$ . Determine its density at a pressure of 600mmHg.
2. A fixed mass of gas of volume  $546\text{cm}^3$  at  $0^\circ\text{C}$  is heated at constant pressure. Calculate the volume of the gas at  $2^\circ\text{C}$ .
3. A bottle is corked when the air inside is at  $2^\circ\text{C}$  and the pressure is  $1.0 \times 10^5\text{Nm}^{-2}$ . If the cork blows out with a pressure of  $3.0 \times 10^5\text{Nm}^{-2}$ , calculate the temperature to which the bottle must be heated for this to happen. (Assume the bottle does not expand).

## 7.0 REFERENCES/FURTHER READING

- Awe, O. and Okunola, O. O. (1986). *Comprehensive Certificate Physics*, Ibadan: University Press Limited.
- Ference, M. (Jnr.), Lemon, H.B. and Stephenson, R. J. (1970). *Analytical Experimental Physics*, Chicago: The University of Chicago Press.
- Feynman, R. P., Leighton, R. B. and Sands, M. (1971). California: The Feynman Lectures on Physics, Addison – Wesley Publishing Company.
- Flowers, B. H. and Mendoza, E. (1970). *Properties of Matter*, London: John Wiley and Sons Limited.
- Noaks, M. A. (1963). *New Intermediate Physics*, Canada: Macmillan and company Limited.
- Soars, F. W., Zemansky, M.W. and Young, H. D. (1980). *College Physics*, London: Addison – Wesley Publishing Company.

Tyler, F. (1966). *Heat and Thermodynamics*, London: Edward Arnold Publisher Limited.

Wilkinson, J. (1983). *Essentials of Physics*, Australia: McMillan Education Limited.

Zemansky, M. W., (1968). *Heat and Thermodynamics*, New York: McGraw Hill.



## MODULE 2

Unit 1	Molar Heat Capacity of Gases
Unit 2	Conduction of Heat
Unit 3	Convection
Unit 4	Radiation
Unit 5	Molecular Properties of Materials

### UNIT 1 MOLAR HEAT CAPACITY OF GASES

#### CONTENTS

1.0	Introduction
2.0	Objectives
3.0	Main Content
3.1	Molar Heat Capacities of Gases
3.1.1	Work Done by an Expanding Gas
3.2	Molar Heat Capacities at Constant Volume and Constant Pressure
3.2.1	Molar Heat Capacity at Constant Volume $C_V$
3.2.2	Molar Heat Capacity at Constant Pressure $C_P$
3.3	Isothermal and Adiabatic Expansion of Gases
4.0	Conclusion
5.0	Summary
6.0	Tutor-Marked Assignment
7.0	References/Further Reading

#### 1.0 INTRODUCTION

So far we have considered the specific heat capacities of solids and liquids especially when we have to determine how much heat energy is absorbed when they are heated. We have not considered the specific heat capacity of gases. This is due to the fact that the behaviour of gases is quite different from that of liquids and solids.

For example, in gases, we have to consider the following parameters (properties) when we are examining the behaviour of gases:

- the pressure (P)
- the volume (V)
- the temperature (T)
- the amount of gas in moles (n)

These properties have been studied under gas laws in the Unit 5. However one property that is crucial to the gases is the heat capacities

under constant volume and under constant pressure. Since the amount of gases is in terms of number of moles, we shall therefore be talking about molar heat capacities of gases. Hence in this unit, we shall examine the concept of molar heat capacities of gases under these two conditions: constant volume and constant pressure.

## 2.0 OBJECTIVES

At the end of this unit, you should be able to:

- explain the work done by expanding volume of gas
- define molar heat capacity of a gas at constant volume
- define molar heat capacity of a gas at constant pressure
- explain the meaning of isothermal expansion
- explain the meaning of adiabatic expansion
- relate the molar heat capacity at constant pressure with that at constant volume.

## 3.0 MAIN CONTENT

### 3.1 Molar Heat Capacities of Gases

You will recall that in calculating the quantity of heat (**Q**) acquired by a solid or a liquid we used the expression:

$$Q = mc\Delta\theta \dots\dots\dots (6.1)$$

Where, *m* is the mass of the solid/liquid, *c* is specific heat capacity of the substance, and  $\Delta\theta$  is the change in temperature.

It is more convenient to use the concept of mole to describe the amount of a substance especially gases. So, first we will learn about the mole.

By definition, one mole (1 mol) of any substance is the quantity of matter such that its mass in grammes is numerically equal to the molecular mass *M* (often called the molecular weight). So to calculate the number of moles *n* numerically, divide the mass *m* in grammes by the molecular mass *M*.

$$\begin{aligned} \therefore n &= \frac{m}{M} \\ \therefore m &= nM \dots\dots\dots (6.2) \end{aligned}$$

Therefore the Eq. (6.1), becomes:

$$\therefore Q = nMc\Delta\theta \dots\dots\dots (6.3)$$

$$\therefore \frac{Q}{n\Delta\theta} = Mc \dots\dots\dots (6.4)$$

The product  $Mc$  is called the molar heat capacity

$$\therefore C = Mc \frac{Q}{n\Delta\theta} \dots\dots\dots (6.5)$$

Which is defined as the quantity of heat  $Q$  in joules required to raise the temperature of 1 mole of gas through 1 K or 1°C.

$$\therefore Q = nC\Delta\theta \dots\dots\dots (6.6)$$

Note that small  $c$  is the specific heat capacity while the big  $C$  is the molar specific heat capacity. It is the molar heat capacity that is mostly associated with the gases though it could also be used for solids and liquids.

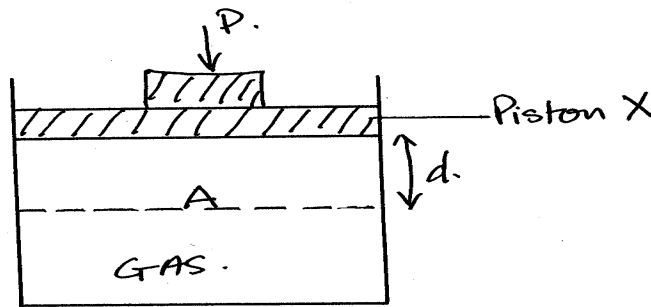
You would have noticed that the behaviour of gases under heat is quite different from the behaviour of solids and liquids. Molecules of a gas are moving about in different directions with different speeds at any instant. This therefore describes the random motion of the molecules.

The internal energy of the gas is therefore the Kinetic Energy (KE) of its random motion. This Kinetic energy, as will be shown later, depends on the temperature of the gas. The higher the temperature, the greater the internal energy (kinetic energy) of the gas. Therefore, now

**an ideal gas is defined as one which obeys Boyle's law and whose internal energy depends on the temperature of the gas and is independent of its volume.**

### 3.1.1 Work Done by an Expanding Gas

Consider a given mass of gas in a container shown in fig. 6.1.



**Fig. 6.1: Work Done by Expanding Gas**

If the gas is warmed it expands, the gas does external work because it will be observed to have pushed back a piston X against some external pressure P.

The heat supplied is shared between the work done against the external work and in increasing the internal energy of the gas because the molecules move faster and its Kinetic energy is increased.

Hence, heat supplied =  $\Delta Q = \Delta U + \Delta W$  ..... (6.7)

Where,  $\Delta Q$  is the increase in heat energy,  $\Delta U$  is the increase in internal energy and  $\Delta W$  is the work done as a result of expansion, work done against external pressure P.

The expression =  $\Delta Q = \Delta U + \Delta W$  is derived from the first law of thermodynamics which is also related to the law of conservation of energy which you will study later.

If the external pressure is constant with a value of P while the volume of the gas expands by  $\Delta V$ , and if the area of the piston X is A, moving through a distance d, then the increase in work done against the external pressure  $P = \Delta W$

$$\begin{aligned} &= \text{force} \times \text{distance} \\ \Delta W &= F \times d \text{ ..... (6.8)} \end{aligned}$$

But as you know the pressure is defined as  $P = \frac{F}{A}$

$$\begin{aligned} \therefore F &= PA \\ \therefore \Delta W &= PA = P\Delta V && \text{(where, } \Delta V = Ad) \\ \therefore \Delta Q &= \Delta U + P\Delta V \end{aligned}$$

In an ideal gas, the work done in separating molecules against attractive forces between them is ignored. This is not so with real gases where the Van der Waal's forces have to be considered. It is also assumed that there is no frictional force when the piston moves.

### 3.2 Molar Heat Capacities at Constant Volume and Constant Pressure

The heat capacity of a gas depends on the condition under which it is heated namely:

- at constant volume or
- at constant pressure

At constant volume, we would represent the molar heat capacity by  $C_V$ . At constant pressure, we would represent the molar heat capacity by  $C_P$ .

#### 3.2.1 Molar Heat Capacity at Constant Volume $C_V$

At constant volume, the volume of the gas is kept at constant volume in such a way that there is no work done by the gas when it absorbs heat. The entire heat is therefore used in changing the internal energy of the gas.

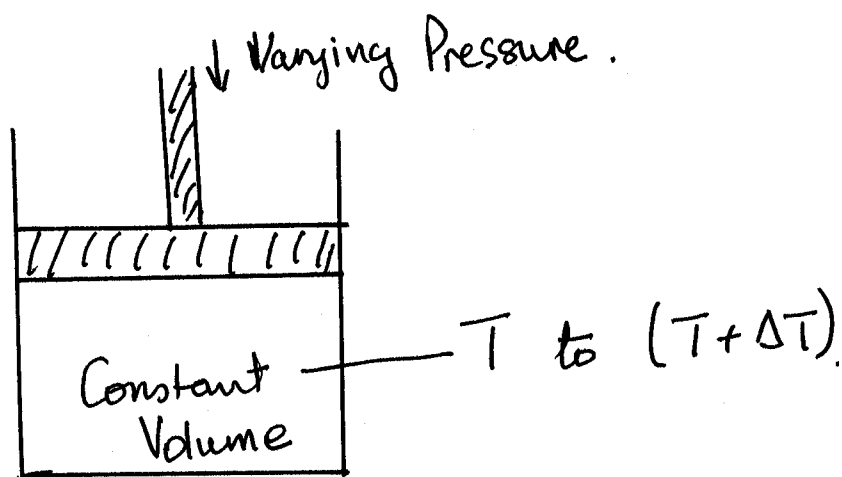


Fig. 6.2: Molar Heat Capacity at Constant Volume

**The molar heat capacity at constant volume  $C_V$ , is therefore defined as the heat required to raise 1 mole of gas by 1 Kelvin (or 1 Celsius) degree when its volume is kept constant.**

$$C_V = \frac{Q}{n\Delta\theta}$$

$$\therefore Q = n C_V \Delta\theta$$

where,  $n$  is the number of moles of gas,  $C_V$  is the molar heat capacity of the gas, and  $\Delta\theta$  is change in temperature of the gas.

The unit of molar heat capacity at constant volume  $C_V$  is  $J \text{ mol}^{-1}K^{-1}$  or  $J \text{ mol}^{-1}^{\circ}C^{-1}$ . The specific heat capacity at constant volume  $C_V$  is the heat required to raise the temperature of 1kg mass of the gas by 1K or  $1^{\circ}C$ .

The molar mass of hydrogen is 2g therefore  $1\text{kg} = 1000\text{g}$  which is 500 times the mass of 1 mole.

$$\therefore C_V = 500 C_V \text{ for hydrogen}$$

Remember the unit of  $C_V$  is  $J \text{ kg}^{-1}K^{-1}$  or  $J \text{ kg}^{-1}^{\circ}C^{-1}$ .

At constant volume, therefore, all the heat supplied to 1 mole of the gas is used in raising the internal energy of the gas.

From,  $\Delta Q = \Delta U + P\Delta V$

Since no external work against pressure is done. Therefore  $P\Delta V$  is zero. Substitute in the above Eq., we get

$$\therefore \Delta Q = \Delta U = nC_V (T_2 - T_1) = nC_V \Delta T$$

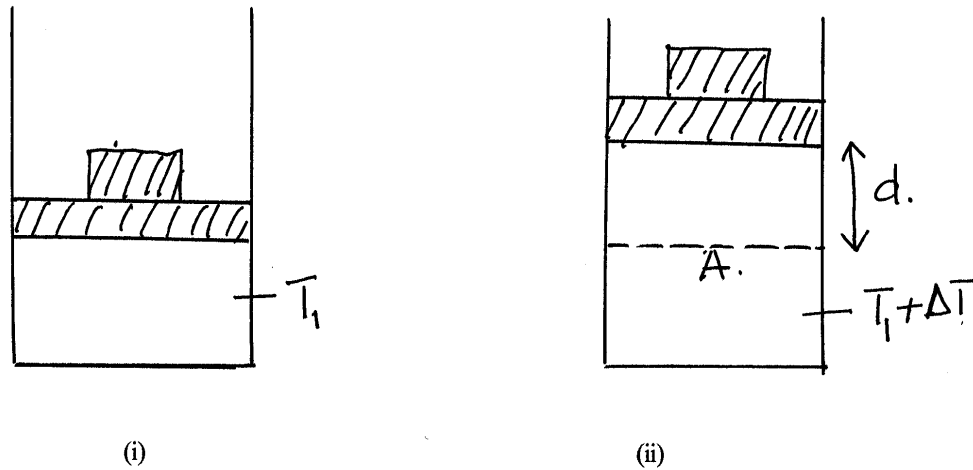
Where  $n = 1$  mole

$$\therefore \Delta Q = C_V \Delta T \dots\dots\dots (6.9)$$

For an ideal gas in which there are no attractive forces among the molecules and each molecule has negligible volume  $C_V$  is independent of the volume of gas. If the temperature of the gas rises from  $T_1$  to  $T_2$ , the gain in internal energy ( $\Delta U$ ) is  $C_V (T_2 - T_1)$  for one mole of gas no matter what volume the gas may be initially or may finally occupy. Thus the internal change in energy depends only on the temperature change.

### 3.2.2 Molar Heat Capacity at Constant Pressure $C_p$

In this case, we are supplying heat to the system where the pressure is constant. Thus, the heat is used in changing the internal energy of the gas as well as doing some work against the constant external pressure  $P$  (fig. 3.3).



**Fig. 6.3: Molar Heat Capacity at Constant Pressure**

The molar heat capacity of a gas at constant pressure  $C_p$  is the heat required to raise the temperature of 1 mole of gas at constant pressure by 1K or 1°C.

$$C_p = \frac{Q}{n\Delta\theta} \dots\dots\dots (6.10)$$

Thus the unit of  $C_p$  is  $J \text{ mol}^{-1} \text{ K}^{-1}$  or  $J \text{ mol}^{-1} \text{ }^\circ\text{C}^{-1}$

On the other hand, the specific heat capacity at constant pressure  $C_p$  is the heat required to raise the temperature of 1kg mass of a gas at constant pressure by 1kg (or 1°C).

When heat is supplied to change the temperature of the gas from  $T_1$  to  $T_2$ , there is change in volume  $\Delta V$  (fig. 3.3(ii)) and increase in internal energy ( $\Delta U$ ). We have known that  $\Delta U$ , the internal energy of the gas, which is independent of volume  $C_v$ , is for 1K or 1°C change in temperature.

From, 
$$\Delta Q = \Delta U + \Delta W$$

Where,  $\Delta W$  is work done by the gas and  $\Delta U = C_v \Delta T$  for 1 mole of gas.

$$\therefore \Delta Q = C_p = C_v \Delta + \Delta W \text{ \# for 1 mole of gas } \dots\dots\dots (6.11)$$

But as we know that  $\Delta W = P\Delta V$

$$\therefore C_p = C_v\Delta T + P\Delta V \dots\dots\dots (6.12)$$

For an ideal gas from the equation of state of a gas, we know that

$$PV = nRT$$

If there is an increase in volume of  $\Delta V$  when there is a change in temperature of  $\Delta T$ , then

$$\therefore P(V + \Delta V) = nR(T + \Delta T)$$

$$\therefore PV + P\Delta V = nRT + nR\Delta T$$

$$\therefore P\Delta V = nR\Delta T$$

For 1 mole of gas  $n = 1$

$$\therefore P\Delta V = nR\Delta T$$

$$\therefore C_p = C_v\Delta T + R\Delta V$$

Where,  $\Delta T = 1\text{K}$  or  $1^\circ\text{C}$

$$\therefore C_p = C_v + R$$

$$\therefore C_p - C_v = R \dots\dots\dots (6.13)$$

At constant pressure therefore, for an ideal gas  $C_p$  is always greater than  $C_v$ . The difference  $R$  is the external work done when the gas is warmed at constant pressure so that its temperature changes by  $1\text{K}$  or  $1^\circ\text{C}$ .

### SELF ASSESSMENT EXERCISE

One mole of a gas has volume of  $2.23 \times 10^{-2}\text{m}^3$  at a pressure of  $1.01 \times 10^5\text{Pa}$  (N) at  $0^\circ\text{C}$ . If the molar cap city at constant pressure is  $28.5\text{J mol}^{-1}\text{K}^{-1}$ . Calculate the molar heat capacity as constant volume.

### 3.3 Isothermal and Adiabatic Expansion of Gases

When a solid or liquid is heated, you would have observed that its volume increase very slightly. Thus the external work done against pressure is very small. Consequently the two molar heat capacities for solids and liquids are practically equal. That is, the specific heat capacities  $C_v$  and  $C_p$  are the same.

However, when real gases expand, some work is done against molecular attractive forces. This is the internal energy. The Van der waal's forces are appreciably significant in this case.



In  $C_p - C_v = R$ ,  $R$  represents the external work done when an ideal gas expands at constant pressure. For real gases  $C_p - C_v > R$  by the amount of internal work done when the gas expands at constant pressure.

When an ideal gas is allowed to expand under a constant temperature, the process is described as **isothermal expansion**.

Under this condition there is no change in internal energy because  $\Delta U$  depends on  $\Delta T$ .

From the First Law of Thermodynamics,

$$\Delta Q = \Delta U + P\Delta V$$

$$\therefore \Delta Q = \Delta U + P\Delta V \quad \text{since } \Delta U = 0 \text{ at isothermal condition ..... (6.14)}$$

The heat supplied to maintain it at constant temperature then is equal to the external work done. Since the temperature is kept constant, an ideal gas therefore obeys Boyle's law

$$PV = \text{Constant}$$

during isothermal changes.

If a gas, on the other hand, is allowed to expand without heat entering or leaving the gas (by insulating its cylinder and piston) the energy needed for the external work is taken from the internal energy of the gas.

This process is described as **adiabatic expansion**.

$$\text{From,} \quad \Delta Q = \Delta U + P\Delta V$$

$$\text{Since,} \quad \Delta Q = 0$$

$$\therefore P\Delta V = - \Delta U \text{ ..... (6.15)}$$

Consequently, the temperature of the system falls. Contrarily, when the gas is compressed under this condition (adiabatic condition), the work done on the gas produces a rise in internal energy, which is equal to the work done. This implies that the temperature of the gas rises. The gas is then said to have undergone **an adiabatic change when no heat enters or leaves the system**.

For adiabatic changes, it can be shown that

- $PV^\gamma = \text{Constant} \text{ ..... (6.16)}$

Where,  $\gamma = \frac{C_p}{C_v}$

- $TV^{\gamma-1} = \text{Constant} \dots\dots\dots (6.17)$

Note that isothermal and adiabatic formulae apply to changes in P, V and T which take place under reversible conditions.

The following assumptions are to be noted:

- no frictional force exists when a piston moves during the gas expansion or contraction.
- no heat is produced in the gas by eddies or swirls of gas during expansion or contraction.

#### 4.0 CONCLUSION

In order to determine the quantity of heat lost or absorbed by a substance, we often use the specific heat capacity to do so as one of the properties. Another convenient property that we use is the molar heat capacity. This concept is used when the quantity of heat absorbed is to be determined with gases. The molar heat capacity of a gas is considered under constant volume or under constant pressure. When an amount of gas (n) absorbs heat under constant volume we use the molar heat capacity at constant volume  $C_v$ . Under this condition the heat absorbed is used to change the internal energy only.

Under constant pressure, the heat absorbed is used to change the internal energy of the gas as well as the work done against a constant pressure.  $C_p$  represents the molar heat capacity.

For one mole of gas, heat absorbed at constant volume is given by

$$\Delta Q = C_v \Delta T$$

At constant pressure

$$\Delta Q = nC_p = nC_v \Delta T + nR \Delta T$$

For one mole of gas where  $n = 1$

$$\Delta Q = C_p = C_v \Delta T + R \Delta T$$

For one Kelvin rise in temperature

$$\Delta Q = C_p = C_v + R$$

$$\therefore C_p = C_v + R$$

## 5.0 SUMMARY

In this unit you have learnt:

- That on the expansion of a given mass of gas by heating, work is done;
- That molar heat capacity is used for the heat absorbed by a gas constant volume  $C_V$  and constant pressure  $C_P$ ;
- That there is a relationship between specific heat capacity  $c$  and molar heat capacity  $C$ ;
- Molar heat capacity at constant volume  $C_V$  is defined as the heat required to raise one mole of gas by 1K when its volume is kept constant;
- Molar heat capacity of a gas at constant pressure  $C_P$  is the heat required to raise the temperature of 1 mole of the gas at constant pressure by 1K;
- When a gas is allowed to expand at constant temperature the process is described as an isothermal expansion;
- When a gas is allowed to expand without heat entering or leaving the gas, the gas is said to undergo an adiabatic expansion;
- Work is done with rise in internal energy.

### ANSWER TO SELF ASSESSMENT EXERCISE

From  $PV = RT$

$$\therefore R = \frac{PV}{T}$$

$$= \frac{1.01 \times 10^5 \frac{\text{N}}{\text{m}^2} \times 2.23 \times 10^{-2} \text{m}^2}{273\text{K}}$$

$$= 8.25\text{J mol}^{-1}\text{K}^{-1}$$

From,  $C_P = C_V + R$

$$\begin{aligned} \therefore C_V &= C_P - R \\ &= 28.5 = \frac{\text{J}}{\text{molK}} - 8.25 \frac{\text{J}}{\text{molK}} \\ &= 20.25\text{J mol}^{-1}\text{K}^{-1} \end{aligned}$$

## 6.0 TUTOR-MARKED ASSIGNMENT

Two grammes of a gas initially at  $27^{\circ}\text{C}$  is heated at constant pressure of  $1.0 \times 10^5 \text{ pa}$  so that its volume increases from  $0.250\text{m}^3$  to  $0.375\text{m}^3$ , calculate:

- (i) the external work done
- (ii) the increase in internal energy
- (iii) the heat supplied

(Relative molecular mass of the gas is 2g,  $C_v = 2.0\text{J mol}^{-1}\text{K}^{-1}$   $C_p = 28.5\text{J mol}^{-1}\text{K}^{-1}$ ).

## 7.0 REFERENCES/FURTHER READING

Awe, O. and Okunola, O. O. (1986). *Comprehensive Certificate Physics*, Ibadan: University Press Limited.

Ference, M. (Jnr.), Lemon, H.B. and Stephenson, R. J. (1970). *Analytical Experimental Physics*, Chicago: The University of Chicago Press.

Feynman, R. P., Leighton, R. B. and Sands, M. (1971). *The Feynman Lectures on Physics*, California: Addison – Wesley Publishing Company.

Flowers, B. H. and Mendoza, E. (1970). *Properties of Matter*, London: John Wiley and Sons Limited.

Noaks, M. A. (1963). *New Intermediate Physics*, Canada: Macmillan and company Limited.

Soars, F. W., Zemansky, M.W. and Young, H. D. (1980). *College Physics*, London: Addison – Wesley Publishing Company.

Tyler, F. (1983). *Heat and Thermodynamics*, London: Edward Arnold Publisher Limited.

Wilkinson, J. (1983). *Essentials of Physics*, Australia: McMillan Education Publishers.

Zemansky, M. W., (1968). *Heat and Thermodynamics*, New York: McGraw Hill Book Company.

## UNIT 2 CONDUCTION OF HEAT

### CONTENTS

- 1.0 Introduction
- 2.0 Objectives
- 3.0 Main Content
  - 3.1 Conduction of Heat Energy
    - 3.1.1 Factors Affecting Conduction
    - 3.1.2 Thermal Conductivity of a Material
  - 3.2 Lagged and Unlagged Bars
    - 3.2.1 Uniform Bar Lagged and Unlagged
    - 3.2.2 Non-Uniform Bar Lagged
  - 3.3 Conduction of Heat through a Good Conductor and Bad Conductor in Series
  - 3.4 Measuring the Thermal Conductivity of a Good Conductor
  - 3.5 Measuring the Thermal Conductivity of a Bad Conductor
- 4.0 Conclusion
- 5.0 Summary
- 6.0 Tutor-Marked Assignment
- 7.0 References/Further Reading

### 1.0 INTRODUCTION

In Physics, we are not only interested in knowing the different forms of energy but how the heat energy may be transferred from one point to another. In this module, we shall consider the three ways by which heat energy is transferred from one source to another. This idea can be viewed as another property of matter, that is, that matter as solids, liquids and gases can act as medium of carrying heat energy from one point to another. The three modes of heat transfer are conduction, convection and radiation.

At the elementary level, one may be satisfied with the use of molecular theory in explaining the three modes of transfer of heat. However, at higher level, we shall go beyond this level by discussing quantitatively conduction of heat in terms of thermal conductivity of a solid and radiation of heat energy through space. We shall consider good and bad conductors (insulators) and conductors in series. We shall deal mainly with conduction of heat in this unit. Transfer by convection will be discussed in the next unit.

## 2.0 OBJECTIVES

At the conclusion of this unit, you should be able to:

- state the factors that affect thermal conductivity
- define the thermal conductivity of a good conductor and insulator
- measure the thermal conductivity of a good conductor
- measure the thermal conductivity of a bad conductor
- solve problems involving thermal conductivity.

## 3.0 MAIN CONTENT

### 3.1 Conduction of Heat Energy

Consider a long silver spoon dipped inside a hot soup. After sometime, the other end of the spoon becomes hot. The transfer of heat energy through the material by conduction could explain this observation.

You would have noted that one factor is obvious in this conduction of heat. That is, one end is at a higher temperature than the other. In the study of conduction of heat through solids, we would like to discuss what factors affect the rate of conduction of heat through solids. In the next sub-section, you will study about the factors that affect conduction.

#### 3.1.1 Factors Affecting Conduction

Consider a state of material with parallel faces of cross-sectional area  $A$  at right angles to the direction of the flow of heat. The heat  $Q$  as shown in fig. 7.1 will flow from high temperature region  $\theta_2$  to a low temperature region  $\theta_1$ . That means  $\theta_2$  is greater than  $\theta_1$ . Let the distance between these temperatures regions be  $L$ .

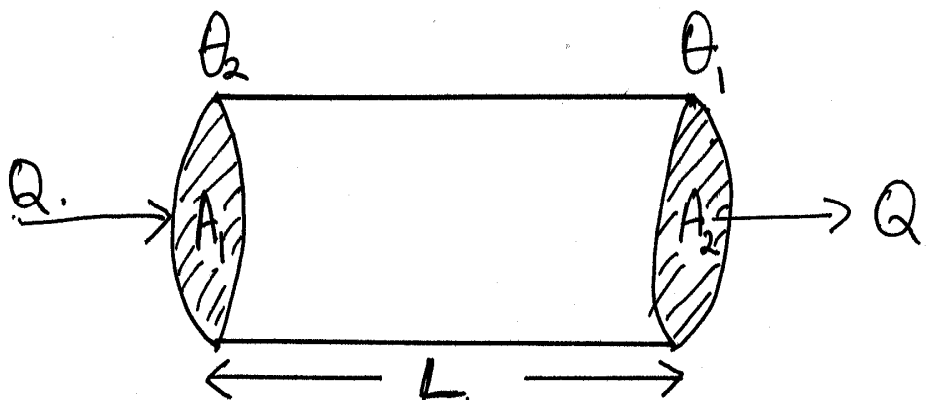


Fig. 3.1

If heat Q takes time t to be transferred across the section of this material of length L, experimentally it has shown that the rate at which the quantity Q is transferred with respect to the time within this region of length L is

(i) Proportional to the cross-sectional area A:

$$\text{i.e. } \frac{Q}{t} \propto A \dots\dots\dots (7.1)$$

(ii) Proportional to the temperature gradient within this region where the temperature gradient is defined as

$$\text{i.e. } \frac{Q}{t} \propto \frac{\theta_2 - \theta_1}{L} \dots\dots\dots (7.2)$$

Combining these two ideas (Eq. (7.1) and Eq.(7.2)) by saying that the rate of transfer of heat is proportional to the area and temperature gradient, give:

$$\begin{aligned} \text{i.e. } \frac{Q}{t} &\propto A \times \frac{\theta_2 - \theta_1}{L} \\ \therefore \frac{Q}{t} &= kA \frac{(\theta_2 - \theta_1)}{L} \dots\dots\dots (7.3) \end{aligned}$$

where, k is the constant of proportionality. k is a factor depending on the material.

**SELF ASSESSMENT EXERCISE 1**

State the factors that affect the conduction of heat.

**3.1.2 Thermal Conductivity of a Material**

We have been able to express the rate at which heat is transferred from a point A<sub>1</sub> to point A<sub>2</sub> in Fig. 7.1 as

$$\frac{Q}{t} = kA \frac{(\theta_2 - \theta_1)}{L}$$

k is therefore numerically equal to the heat transferred per second per unit area of cross-section when unit temperature gradient is set up normal to the area.

$$k = \frac{\text{Rate x heat transferred}}{\text{Area x temperature gradient}}$$

$$k = \frac{Q/t}{\frac{A(\theta_2 - \theta_1)}{L}} \dots\dots\dots (7.4)$$

UNIT of k: From Eq.(7.4), k can be expressed as:

k is a constant of proportionality known as the thermal conductivity for the material for Eq. (7.3) k is written as,

$$\begin{aligned} k &= \frac{Q/t}{\text{Area x temperature gradient}} \\ &= \frac{J/s}{m^2 \times (^{\circ}C)} \\ &= Js^{-1}m^{-1}C^{-1} \\ &= Wm^{-1}C^{-1} \end{aligned}$$

On in terms of the absolute scale, the unit of k can be written as

$$k = Wm^{-1}K^{-1}$$

Copper, which is a very good conductor of heat, has its value  $k = 400 Wm^{-1}K^{-1}$  and that of air =  $0.02 Wm^{-1}K^{-1}$

One can define the thermal conductivity of a material:

***“The thermal conductivity of a material is the rate of transfer of heat per unit area per unit temperature gradient through the face of the material with the face perpendicular to the direction of the transfer of heat provided steady state is maintained.”***

Now you may ask: What does it mean by steady state situation?

A steady state is reached when the rate of transfer of heat through a given cross-sectional area does not change with respect to time. This therefore brings us to the point to show how a steady state is achieved and that is through lagging or unlagging. You will discover the meaning of lagging or unlagging in the next section.



### 3.2 Lagged and Unlagged Bars

Heat may be transferred under two conditions:

- Lagged material – when the material is lagged
- Unlagged material – when the material is unlagged

We shall now describe the conduction of heat through two bars – one lagged and the other unlagged.

In this section we shall consider the conduction of heat through:

- a uniform bar when lagged and when it is not lagged and
- a non-uniform bar when it is lagged.

#### 3.2.1 Uniform Bar Lagged and Unlagged

In this case we are interested in studying how the temperature gradient varies with other factors such as the thermal conductivity  $k$ , the cross-sectional  $A$  and the rate of transfer of heat per second. Note that  $k$  varies with different materials but is constant for a particular material.

Let us consider a lagged bar PQ of length  $x$ , such that P is at temperature  $\theta_2$  while Q is at temperature  $\theta_1$  (Fig. 7.2)

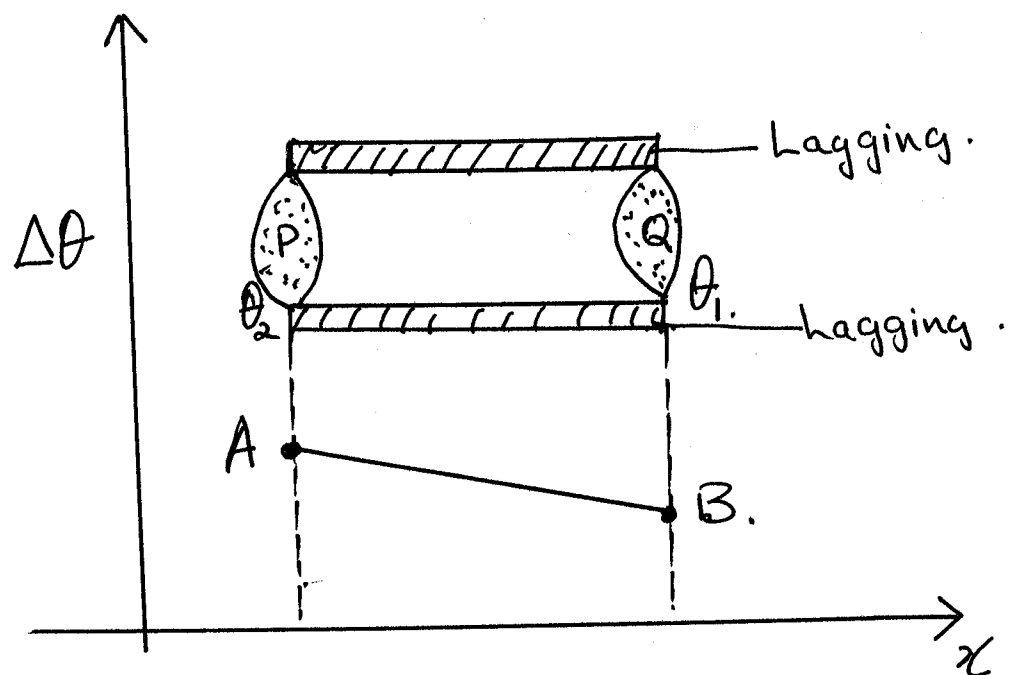


Fig. 7: Temperature Gradient for a Uniformly Lagged Bar

In this case  $\theta_2$  is greater than  $\theta_1$ . Hence, heat will be transferred from P to Q. If A is the uniform cross-sectional area of PQ, the rate of transfer of heat from P to Q is given as

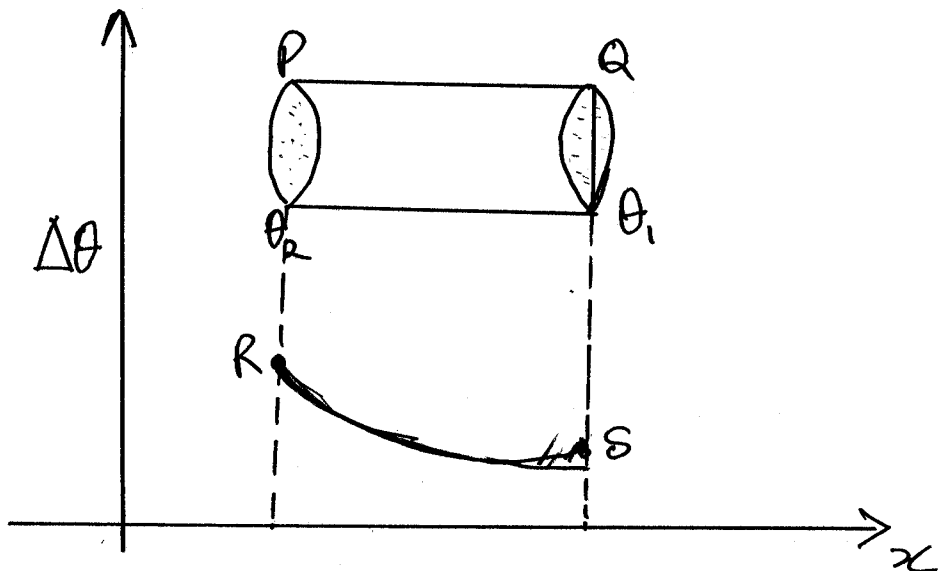
$$\frac{Q}{t} = kA \frac{(\theta_2 - \theta_1)}{x}$$

$$\therefore \frac{(\theta_2 - \theta_1)}{x} = \frac{1}{KA} \times \frac{Q}{t}$$

i.e. temperature gradient =  $\frac{1}{KA} \times \frac{Q}{t}$  ..... (7.4)

Under steady state condition, for lagged bar, the part  $\frac{Q}{t}$  is the same on the two surfaces P and Q since no heat is lost to the surrounding. Thus with k and A being constant, both sides of the equation are constant.

Consequently, for lagged uniform bar the temperature gradient is constant as indicated on the graph of  $\theta_2 - \theta_1$  against x to produce the line AB. (Fig. 7.2). In simple words, temperature gradient,  $\frac{Q}{t}$ , flowing through every cross-section from the hot to cold end is constant as no heat passes through the sides.



**Fig. 7.3: Temperature Gradient for a Uniform Unlagged Bar**

However, if the bar is unlagged, then from equation,

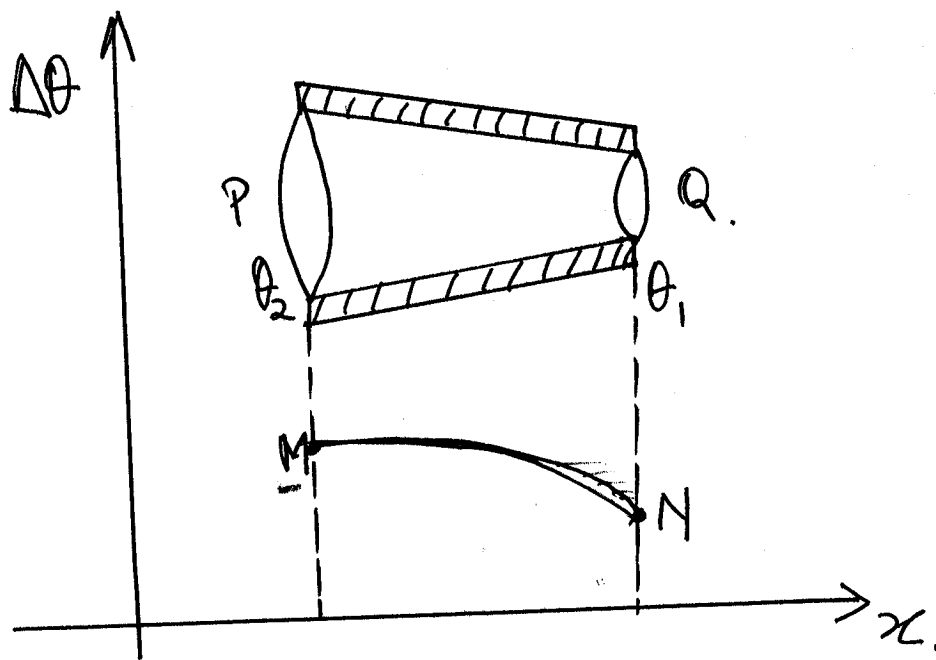
$$\frac{(\theta_2 - \theta_1)}{x} = \frac{1}{KA} \times \frac{Q}{t} \dots\dots\dots (7.5)$$

$\frac{Q}{t}$  under the unlagged condition will not be the same from face P to face Q. The value decreases from P to Q. Hence the gradient becomes smaller from the hot end P to the cold end Q. Thus the variation of the temperature gradient is a curve RS in fig. 7.3 with a diminishing gradient.

### 3.2.2 Non-Uniform Bar Lagged

Let us now consider another bar whose cross-sectional area is not uniform but is lagged as shown in fig. 7.4. It will be observed that

- (i)  $\frac{Q}{t}$ , the rate of transfer of heat will be the same at both ends because the material is lagged.
- (ii) The cross-sectional A, decreases from P to face Q, thus from the expression (7.4) the temperature gradient increases. This is shown by the gradient MN from hot end to cold end of the bar (fig. 7.4)



**Fig. 7.4: Temperature Gradient – Non-Uniform Bar and Lagged**

The concept of rate of transfer of heat  $\frac{Q}{t}$  may be compared with the rate of flow of current I. From ohm's law,

$$I = \frac{V}{R} \dots\dots\dots (7.6)$$

Where,  $I = \frac{\text{QUANTITY OF CHARGES (Q)}}{\text{TIME t TAKEN IN SECONDS}}$

But  $R = \rho \frac{L}{A} \dots\dots\dots (7.7)$

Where,  $R =$  resistance of the resistor  
 $\rho =$  resistivity of the resistor  
 $L =$  the length of the resistor  
 $A =$  average cross-sectional area

Combining Eq. (7.6) and Eq. (7.7), we get

$$\begin{aligned} \therefore I &= \frac{V}{R} \times \frac{I}{R} \\ &= \frac{1}{\rho} \times \frac{A}{L} \times V \\ \therefore I &= \frac{1}{\rho} \times A \times \frac{V_2 - V_1}{L} \dots\dots\dots (7.8) \end{aligned}$$

Where,  $\frac{1}{\rho} =$  electrical conductivity of wire and,  $\frac{V}{L} =$  potential gradient

On comparing Eq. (7.8)  $I = \frac{1}{\rho} A \frac{V_2 - V_1}{L}$  with

$$\text{Eq. (7.3), } \frac{Q}{t} = kA \frac{(\theta_2 - \theta_1)}{L}$$

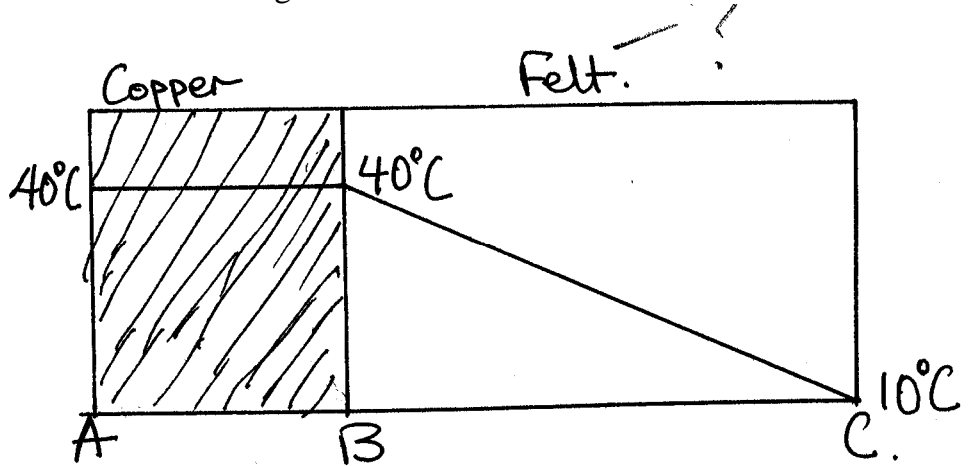
where,  $k =$  the thermal conductivity

**SELF ASSESSMENT EXERCISE 2**

A long steel rod, insulated to prevent heat losses, has one end immersed in boiling water (at atmospheric pressure) and the other end in a water-ice mixture. If the steel rod is 100cm long and cross-sectional area of 5cm<sup>2</sup>, after establishing a steady state condition, how much heat per second is transferred from the steam bath to the ice-water mixture? ( $k$  for steel = 50J (sm<sup>o</sup>C)<sup>-1</sup>?)

### 3.3 Conduction of Heat through a Good Conductor and Bad Conductor in Series

In this section, we are interested in comparing the temperature gradient of the good conductor with that of the bad conductor. Consider a copper tank of thickness AB which is 5mm and lagged with a felt of thickness BC and 5cm as shown in fig 7.5.



**Fig. 7.5: Copper and Felt in Series**

Suppose the temperature of the water in the copper tank is constant at 40 °C throughout the thickness AB and the temperature of the outside of the felt is constant at 10°C.

Given that the thermal conductivity of copper is  $400\text{Wm}^{-1}\text{C}^{-1}$  and that of the felt is  $0.04\text{Wm}^{-1}\text{C}^{-1}$ . At a steady state condition, the rate of heat transfer  $\frac{Q}{t}$  is the same for copper (AB) and the felt (BC).

Using Eq. (7.4), the temperature gradient  $g$  is given as

$$g = \frac{1}{KA} \times \frac{Q}{t} \dots\dots\dots (7.9)$$

Let  $g_{cu}$  be the temperature gradient for copper and  $g_f$  be the temperature gradient for the felt.

$$\therefore g_{cu} = \frac{1}{g_{cu}A_{cu}} \times \frac{Q}{t} \text{ and } \dots\dots\dots (7.10)$$

$$g_f = \frac{1}{k_f A_f} \times \frac{Q}{t} \dots\dots\dots (7.11)$$

where,  $k_{cu}$  and  $k_f$  are the thermal conductivities for the copper and felt respectively.

$A_{cu}$  and  $A_f$  and are the cross-sectional areas of copper and felt respectively, which, in this case, are the same.

Now, dividing Eq. (7.10) by Eq. (7.11), we get

$$\text{Then, } \frac{g_{cu}}{g_f} = \frac{k_f}{K_{cu}} = \frac{0.04}{400} = \frac{4}{4000} = \frac{1}{1000}$$

$$g_{cu} = \frac{1}{1000} g_f$$

This shows that the temperature gradient of copper is 10,000 less than that of the felt. The consequence of this statement is that the temperature of the outer surface of the copper tank is not much less than its inner surface. Hence, the whole lot of the temperature drop from 40 °C to 10 °C occurs across felt, the bad conductor.

### SELF ASSESSMENT EXERCISE 3

Assuming the thermal conductivities of air and brick are 0.02 and 0.6 W m<sup>-1</sup>°C<sup>-1</sup> respectively, calculate the thickness of air equivalent to a thickness of 30cm of brick if two of such brick walls are separated by air gap of 3cm. How much heat per minute would be transferred through them in the steady state when the outside temperatures of brick are 60 °C and 10 °C respectively and the area of cross-section of each is 2m<sup>2</sup>?

### 3.4 Measuring the Thermal Conductivity of a Good Conductor

It is possible to determine the thermal conductivity of a metal bar such as copper or iron. The apparatus used in this determination is called the Searle's apparatus (Fig. 7.9).

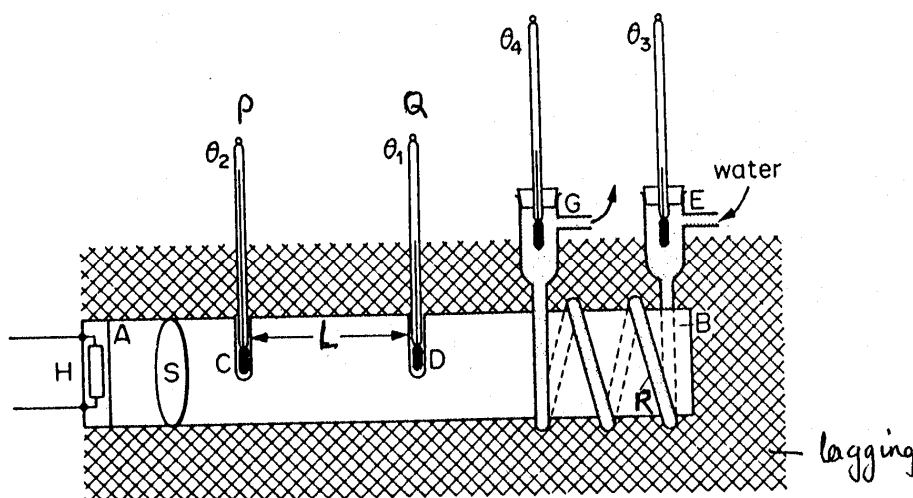


Fig. 7.9: Searle's Apparatus

The following are the essential features of the Searle's apparatus for measuring the thermal conductivity of a good conductor,

- A thick bar so that appreciable heat is transferred through a cross-section
- A reasonable long bar **AB** so that the temperature gradient can be measured accurately.
- A lagged bar so that no heat escapes and the heat being transferred is linear along the bar under steady state conditions.

### Procedure

The procedure for measuring  $k$ , the thermal conductivity is as follows:

- The lagged bar is electrically heated at one end by an electric supply (H)
- The final steady state temperatures are measured by means of thermometers P and Q placed in deep holds bored in the bar at a known distance  $L$  apart. The temperature at P is  $\theta_2$  and that at Q is  $\theta_1$
- A coiled tube R is in thermal contact with the bar near the other end of the bar enables the heat transfer per second to be measured.
- Water from a constant pressure head flows steadily through the tubes R.
- The inlet and outlet temperatures  $\theta_3$  and  $\theta_4$  are measured
- The set up is left until the temperatures are steady
- The rate of transfer of water  $m$  is measured using a cylinder and a stop clock
- The cross-sectional area  $S$  of the bar is found using vernier calipers to measure the diameter.

The value of  $k$  can then be obtained from the relation

$$\frac{Q}{t} = mC_{\text{water}} (\theta_4 - \theta_3) = kA \frac{(\theta_2 - \theta_1)}{L} \dots\dots\dots (7.12)$$

Alternatively,  $\frac{Q}{t}$  may be determined by measuring the current  $I$  and the potential difference  $V$  of the supply. Thus  $\frac{Q}{t} = IV$ . Thus neglecting the use of the resistance of the coil R.

### 3.5 Measuring the Thermal Conductivity of a Bad Conductor

This is another useful exercise in the laboratory for the determination of the thermal conductivity of a bad conductor. Lee designed the apparatus for this measurement. Hence, the name of apparatus – Lee's apparatus for measuring the thermal conductivity of a bad conductor (Fig. 3.10).

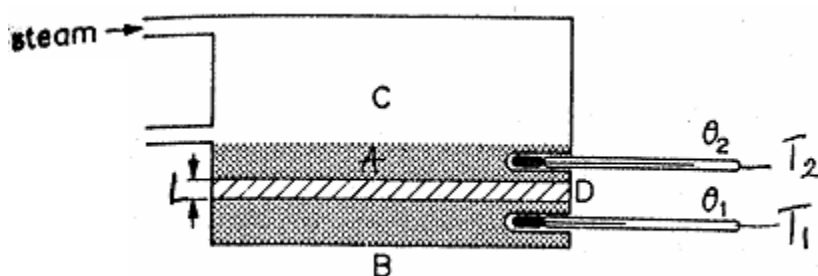


Fig. 7.10

The apparatus is made up of a top cylindrical steam chamber C. At the bottom of this chamber is a thick brass block A with a hole bored into it to hold a thermometer  $T_2$ . Next to this brass block A is the bad conductor specimen D made up of a cardboard or glass in form of a disc with large diameter with small thickness  $d$  so that it gives a greater temperature gradient.

The bad conductor is sandwiched between the brass block A and another second cylindrical brass block B which also has a hole bored into it to hold another thermometer  $T_1$ .

As a precaution, the slabs must be flat and clean. Some Vaseline may be smeared over it in order to improve thermal contact (Fig. 7.10). Heat therefore flows from chamber A through the specimen to the chamber B.

Steam is passed through chamber C until a steady state in temperatures  $\theta_1$  and  $\theta_2$  as measure by  $T_1$  and  $T_2$  respectively.

In this situation, the temperature gradient is  $\frac{(\theta_2 - \theta_1)}{L}$

The next problem is centered on how to measure or determine the rate of loss of heat by chamber B. We therefore have to examine fig. 7.11 (i) and (ii).

The steam chamber C is removed with the brass block A. The specimen is left on top of the lower brass block B. The lower brass block B is then warmed gently by a Bunsen burner until its temperature is a few degrees above  $\theta_1$ , say  $82^\circ\text{C}$ . The burner is then removed and B is



allowed to cool and the readings of its temperature fall with time are taken. The graph of  $\theta$  against time  $t$  (Fig. 7.11 (ii)).

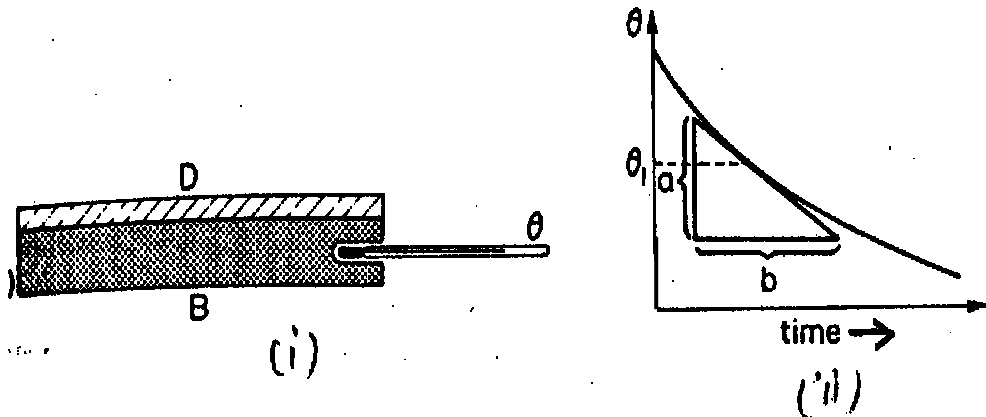


Fig. 7.11

The slope at temperature  $\theta_1$  is then determined as  $\frac{a}{b}$

Let  $m$  be the mass of the brass B and  $C_{\text{brass}}$  the specific heat capacity of brass.

Therefore  $\frac{Q}{t}$  = Rate of loss of heat by cooling

$$\text{at } \theta_1 = mC_{\text{brass}} \frac{a}{b}$$

When the temperature of B is steady, it is losing heat to the surrounding from side and base at exactly the same rate the base is receiving heat by conduction through the specimen D. Thus the rate of losing heat from B is equal to the rate of heat transfer through the specimen in steady state.

$$\therefore \frac{Q}{t} = kA \frac{(\theta_2 - \theta_1)}{d} = mC_{\text{brass}} \frac{a}{b} \dots\dots\dots (7.13)$$

Given the area  $A$  and the thickness  $L$  of the cardboard,  $K$  can be determined.

$$K = mC \frac{a}{b} \times \frac{L}{(\theta_2 - \theta_1)} \times \frac{1}{A} \dots\dots\dots (7.14)$$

**4.0 CONCLUSION**

In this unit we have studied one mode by which heat is transferred through matter-conduction. Conduction of heat through solids materials were examined especially through good and bad conductors of heat.

The thermal conductivity of a solid material was considered as a property for the transfer of heat through solid materials.

The rate of transfer of heat in joules per second has been found to be proportional to the surface area of the solid material  $A$ , and the temperature gradient. If a conductor is of length  $L$  whose ends are at temperatures  $\theta_2$  and  $\theta_1$  and where  $\theta_2$  is greater than  $\theta_1$ , the temperature gradient is defined as the difference in the temperatures per unit length

$$\frac{(\theta_2 - \theta_1)}{L}$$

The rate of transfer of heat at steady state condition in the conduction of heat. To establish this condition implies that the material under consideration must be lagged i.e. insulated so that there is no loss of heat as the heat is being transferred from one end to another.

We would now consider another mode of transfer of heat through convection in the next unit.

## 5.0 SUMMARY

In this unit, you have studied the following:

- The concept of thermal conductivity is applied to both good and bad conductors of heat
- The thermal conductivity of a conductor is used to solve problems under steady state condition
- The rate of conduction of heat, the area of conduction, the thermal conductivity as well as the temperature are related as

$$\frac{Q}{t} = kA \frac{(\theta_2 - \theta_1)}{L}$$

- This relationship was used to consider the temperature gradient when a conductor is lagged or unlagged or when there is a variation in the surface areas when lagged
- One principle used in solving problems on conduction of heat through bad conductors of heat is the use of the equivalent material.
- Methods of how to determine the thermal conductivity of a good conductor and that of a bad conductor were described.

**ANSWER TO SELF ASSESSMENT EXERCISE 1**

The factors that affect the conduction of heat through a solid material are:

- (i) The cross-sectional area  $A$
- (ii) The temperature difference
- (iii) The length of the material
- (iv) The time for the heat to be transferred

Note: (ii) and (iii) defines for us the concept of temperature gradient

$$\left( \frac{\theta_2 - \theta_1}{L} \right)$$

**ANSWER TO SELF ASSESSMENT EXERCISE 2**

$$\theta_2 = 100^\circ\text{C}$$

$$\theta_1 = 0^\circ\text{C}$$

$$L = 100\text{cm} = 1\text{m}$$

$$A = 5\text{cm}^2 = 5 \times 10^{-4}\text{m}^2$$

$$K = 50.2\text{J} (\text{s m}^\circ\text{C})^{-1}$$

$$\text{From, } \frac{Q}{t} = kA \frac{(\theta_2 - \theta_1)}{L}$$

$$\begin{aligned} \therefore \frac{Q}{t} &= 50.2\text{J/sm}^\circ\text{C} \times 5 \times 10^{-4}\text{m}^2 \times \frac{(100 - 0)^\circ\text{C}}{1\text{m}} \\ &= 50.2 \times 5 \times 10^{-4} \times 100\text{J/s} \\ &= 2.51\text{J/s} \\ &= 2.51 \text{ Watt} \end{aligned}$$

## ANSWER TO SELF ASSESSMENT EXERCISE 3

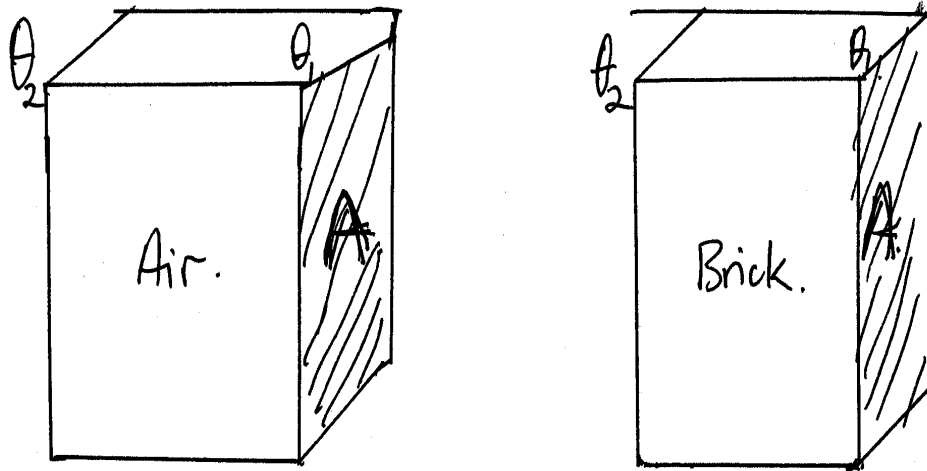


Fig. 7.6

- (a) Let the thickness of air be  $d_1$  and that of the brick be  $d_2$  which is given as  $30\text{cm} = 0.3\text{m}$ . If they are at the same temperature difference  $(\theta_2 - \theta_1)$  across the air and the brick. Then the rate of transfer of heat  $\frac{Q}{t}$  is defined as

$$\frac{Q}{t} = k_1 A \frac{(\theta_2 - \theta_1)}{d_1} \quad \text{for air}$$

where,  $k_1$  = thermal conductivity of air

$$\text{For the brick also, } \frac{Q}{t} = k_2 A \frac{(\theta_2 - \theta_1)}{d_2}$$

where,  $k_2$  = thermal conductivity of the brick

Since  $\frac{Q}{t}$  is the same for the two materials.

$$\therefore k_1 A \frac{(\theta_2 - \theta_1)}{d_1} = k_2 A \frac{(\theta_2 - \theta_1)}{d_2}$$

$$\therefore \frac{k_1}{d_1} = \frac{k_2}{d_2}$$

$$\therefore \frac{0.02\text{Wm}^{-1}\text{C}^{-1}}{d_1} = \frac{0.6\text{Wm}^{-1}\text{C}^{-1}}{0.3\text{m}}$$

$$\begin{aligned} \therefore d_1 &= \frac{0.02 \times 0.3}{0.6} \text{ m} \\ &= 0.01 \text{ m} \\ &= 1.0 \text{ cm} \end{aligned}$$

The thickness of air equivalent to that of the brick is 1.0cm.

(b)

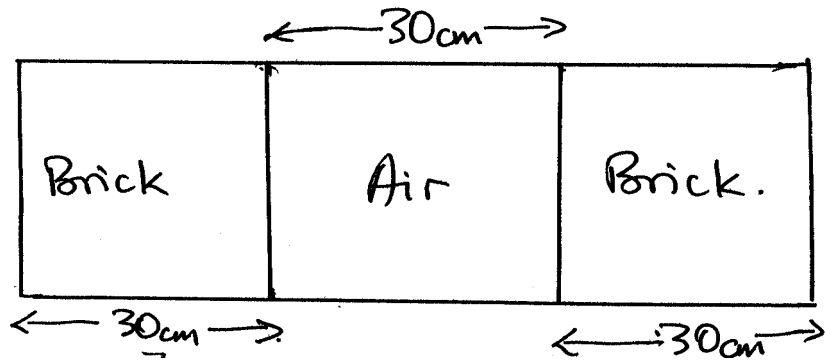


Fig. 7.7

If 30 cm of air is in series with the two bricks, then we have this new picture for the system (fig. 7.7).

From the solution in (a) this arrangement will be equivalent to the new picture in fig. 7.8.

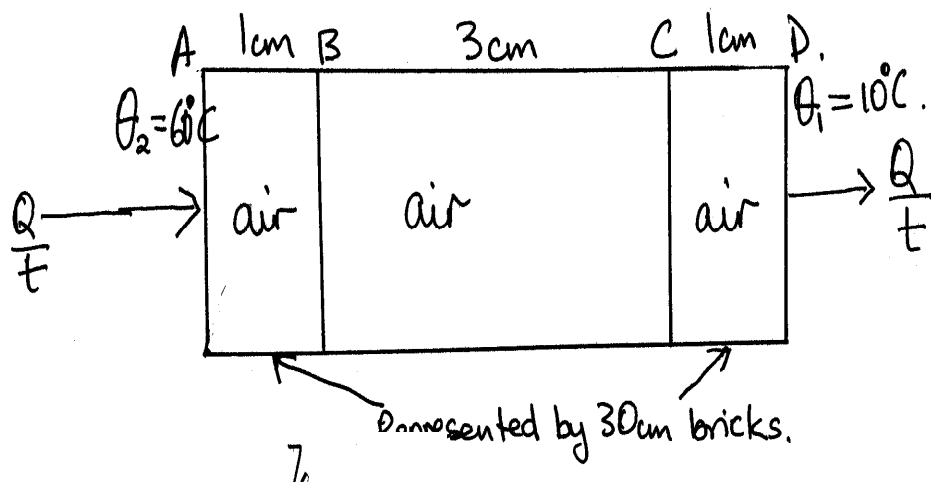


Fig. 7.8

We are interested in calculating the quantity of heat, Q per minute that will pass through from A to D.

$$\frac{Q}{t} = kA \frac{(\theta_2 - \theta_1)}{d}$$

where,  $k$  = thermal conductivity for air =  $0.02 \text{ Wm}^{-1}\text{C}^{-1}$

$A$  = cross-sectional area of bricks =  $2 \text{ m}^2$

$d = AD = 5 \text{ cm} = 0.05 \text{ m}$

$(\theta_2 - \theta_1) = (60 - 10)^\circ\text{C} = 50^\circ\text{C}$  = the temperature difference

$$\begin{aligned} \therefore \frac{Q}{t} &= 0.02 \frac{\text{W}}{\text{m}^\circ\text{C}} \times 2 \text{ m}^2 \times \frac{50^\circ\text{C}}{0.05 \text{ m}} \\ &= \frac{0.02 \times 2 \times 50 \text{ J}}{0.5} \frac{\text{J}}{\text{s}} \text{ for 1 minute we multiply by 60s} \\ &= \frac{0.02 \times 2 \times 50 \text{ J}}{0.5} \times 60 \frac{\text{J}}{\text{min}} \\ &= 2400 \text{ J/min} \end{aligned}$$

The heat energy transfer per minute is **2400J**.

## 6.0 TUTOR-MARKED ASSIGNMENT

1. A 100cm long copper rod, insulated to prevent heat losses has one end maintained at  $150^\circ\text{C}$  and the other at  $0^\circ\text{C}$ . If the copper rod has a cross-sectional area of  $10 \text{ cm}^2$  and after establishing a steady state condition, how much heat per second is transferred from  $150^\circ\text{C}$  end to  $0^\circ\text{C}$  end? (Thermal conductivity of copper =  $385 \text{ J (s m}^\circ\text{C)}^{-1}$ )
2. In double-glazing, two sheets of glass 2mm thick are separated by 10mm of air. The temperatures of the outside glass surface are  $20^\circ\text{C}$  and  $5^\circ\text{C}$  respectively. Calculate the heat per second per unit area being transferred by conduction and the temperatures of the interior glass surfaces assuming steady state condition. (Thermal conductivities of glass and air are  $0.03$  and  $0.02 \text{ Wm}^{-1}\text{C}^{-1}$  respectively).
3. A closed metal vessel contains water (i) at  $30^\circ\text{C}$  and then (ii) at  $75^\circ\text{C}$ . The vessel has a surface area of  $0.5 \text{ m}^2$  and a uniform thickness of 4mm. If the outside temperature is  $15^\circ\text{C}$ , calculate the heat loss per minute by conduction in each case. (Thermal conductivity of the metal =  $400 \text{ Wm}^{-1} \text{ K}^{-1}$ )
4. The following observations were made in an experiment to determine the thermal conductivity of aluminum by using

$$\theta_2 = 85^\circ\text{C}, \theta_1 = 65^\circ\text{C}, \theta_3 = 32^\circ\text{C} \text{ and } \theta_4 = 44^\circ\text{C}$$

Mass of water flowing in 1 minute = 9.9g. The distance between  $\theta_2$  and  $\theta_1 = 0.4 \text{ m}$ . The diameter of the bar = 3cm.

## 7.0 REFERENCES/FURTHER READING

- Awe, O. and Okunola, O.O. (1986). *Comprehensive Certificate Physics*, Ibadan: University Press Limited.
- Ference, M. (Jnr.), Lemon, H.B. and Stephenson, RJ (1970). *Analytical Experimental Physics*, Chicago: The University of Chicago Press.
- Feynman, R.P., Leighton, R.B. and Sands, M (1971). *The Feynman Lectures on Physics*, California: Addison-Wesley Publishing Company.
- Flowers, B.H. and Mendoza, E (1970). *Properties of Matter*, London: John Wiley and Sons Limited.
- Noaks, M.A. (1963). *New Intermediate Physics*, Canada: Macmillan and company Limited.
- Soars, F.W., Zemansky, M.W. and Young, H.D. (1980). *College Physics*. London: Addison-Wesley Publishing Company.
- Tyler, F. (1966). *Heat and Thermodynamics*. London: Edwards Arnold Publisher Limited.
- Wilkinson, J. (1983). *Essentials of Physics*, Australia: Macmillan Education Publishers.
- Zemansky, M.W. (1968). *Heat and Thermodynamics*. New York: McGraw-Hill Book Company.

## UNIT 3      TRANSFER OF HEAT BY CONVECTION

### CONTENTS

- 1.0 Introduction
- 2.0 Objectives
- 3.0 Main Content
  - 3.1 Conduction of Heat in Fluids
  - 3.2 Convection in Fluids
    - 3.2.1 Natural and Forced Convection
    - 3.2.2 Convection of Heat in Liquids
    - 3.2.3 Convection in Gases
  - 3.3 Newton's Law of Cooling
- 4.0 Conclusion
- 5.0 Summary
- 6.0 Tutor-Marked Assignment
- 7.0 References/Further Reading

### 1.0 INTRODUCTION

In Module 2, unit 1, you have learnt about the transfer of heat through solids by conduction. You should have noticed that we did not discuss whether conduction takes place in liquids or gases.

You would also observe that in the transfer of heat by conduction, the material that makes up the solid does not move. The heat energy is simply passed from one molecule to the other i.e. from the hot end of the solid to the cold end of it.

The question you may logically ask is: "Does conduction take place in fluids (liquids and gases)?"

Thus, in this unit, we would show whether conduction takes place in fluids or not. This, therefore, brings us to the study of another mode of transfer of heat energy through matter described as CONVECTION. In the next unit, you will learn about the radiation which is another mode of transfer of heat in matter.

### 2.0 OBJECTIVES

At the end of this unit, you should be able to:

- show that conduction of heat does not take place in liquids and gases (fluids)
- explain the meaning of convection as a mode of transfer of heat in fluids



- differentiate between natural convection and forced convection of heat in matter
- state Newton's law of cooling.

### 3.0 MAIN CONTENT

#### 3.1 Conduction of Heat in Fluids

Liquids and gases are usually referred to as fluids. *Does conduction of heat occur in them?* You should have realized that all liquids, except mercury, which is a metal, are poor conductors of heat. Air and gases, generally are even worse conductors of heat. This idea can be shown by placing a piece of ice wrapped inside a wire gauze and placed in a long test tube filled with water (Fig. 8.1).

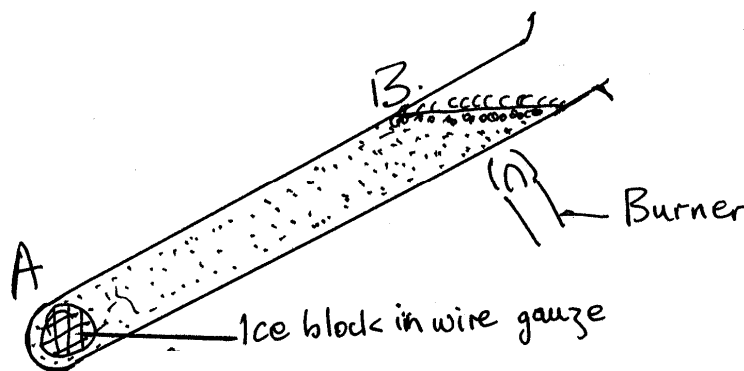


Fig. 8.1

The upper part of the tube **B** is observed to boil after heating it for some time. It will be observed that as the water boils the ice remains unmelted at the bottom of the tube. This means that the heat is not conducted down the tube. The heat stays at the top. Experiments have also shown that air is a poor conductor of heat. Steel wool, crumpled aluminum foil, wollen materials are bad conductors of heat because of the large number of small air pockets within these materials.

#### SELF ASSESSMENT EXERCISE 1

Describe an experiment to show that conduction of heat does not take place in a named liquid.

## 3.2 Convection in Fluids

*The question you may ask now: If conduction of heat does not occur in fluids, how then is heat transferred in fluids?*

Heat is transferred in fluids by convection. Convection is a mechanical displacement of heated part of a fluid. In simple words, it is a phenomenon of transfer of heat with the actual movement on the particles of the body. We usually place a pot of water on top of the cooker to get boiled water to prepare food or to bath if the weather is too cold. The liquid will be in contact with the solid wall of the container, which is usually a metal like an aluminum pot. The container is at a higher temperature than the fluid. The heat is transferred to the fluid. The heated portion of the fluid rises up while the cold fluid on the top comes down. This process continues until the water begins to boil. The process may be explained in this manner. When the water molecules are heated, they expand and as a result of this expansion, the density of the molecules decreases such molecules thus experience an upthrust, according to Archimedes Principle, which makes them to float. Since nature does not allow a vacuum, the colder, heavier molecules take the place of the lighter ones. Thus a current of molecules is created within the liquid. The viscosity of the fluid i.e. fluid friction naturally influences the convectional transfer of heat in fluids.

The term convection is usually applied to the transfer off heat in fluids from one point to another by the actual movement of the particles that make up the fluid.

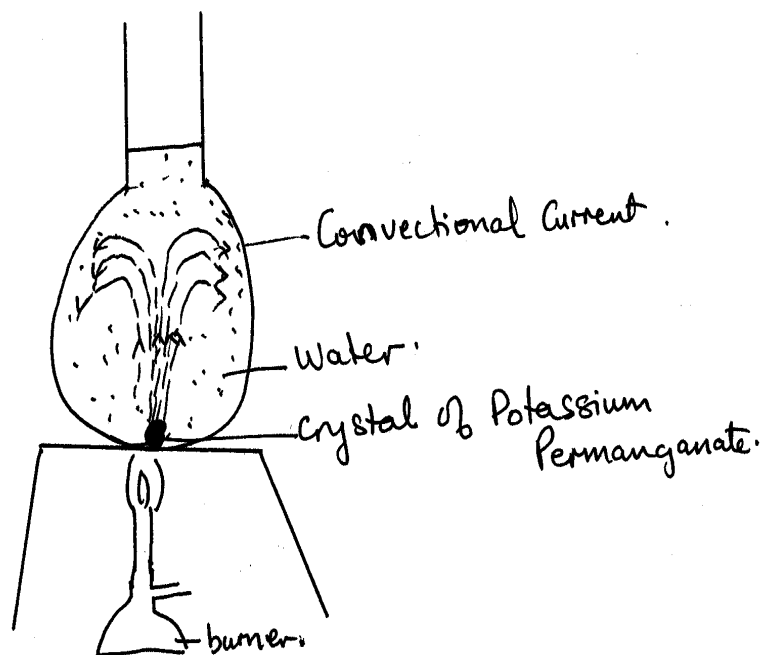
### 3.2.1 Natural and Forced Convection

When the material fluid carries the heat from one place to another due to the differences in density as a result of thermal expansion, the process of the heat transfer is called **natural convection**. An example of this occurs when water in a pot is made to boil.

On the other hand, when the material of the fluid is forced to carry the heat from one place to another by a blower or pump, the process is called **forced convection**. If you place your hot cup of tea or pap under a fan, the heat in the tea or pap will be reduced by forced convection.

### 3.2.2 Convection of Heat in Liquids

Convection in liquids may be demonstrated by placing a crystal of potassium permanganate carefully in a round bottomed flask and then heating the bottom of the flask gently (Fig. 8.2).



You will observe that a rising column of coloured water will occur in the flask. This shows that convection currents have been set up. This is a natural convection. This process again can be explained by the expansion of water molecules at the bottom of the flask due to the heat acquired. Their density decreases and as such, they float according to Archimedes' Principle. The heavier colder molecules then take the places of the hot ones and so a current is created within the bulk of the water. This is the principle applied in the domestic hot water system in cold countries. The hot water circulates by natural convection. However in large buildings, which have central heating systems, a pump is usually used to assist in the circulation of the hot water. This gives us an example of forced convection.

### SELF ASSESSMENT EXERCISE 2

Explain why the coil (element) of an electric kettle is always placed at the bottom and not on top.

### 3.2.3 Convection in Gases

Convection in gases may be demonstrated experimentally by using a glass box with two chimneys A and B as shown in fig. 8.3.

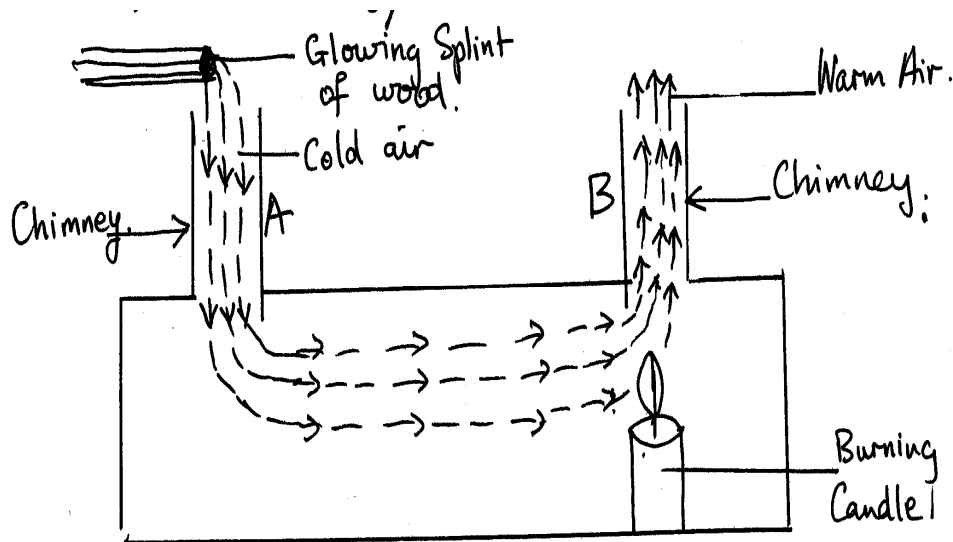


Fig. 8.3

Below chimney B, inside the box, is a burning candle. When a glowing splint of wood is placed above the chimney A, the smoke will be observed to take the path of a convectional current from chimney A to chimney B.

The hot air around the candle rises up and the cold air from A towards B as a result of the differences in temperatures and decreases in density on the expansion of the air particles.

This is the principle behind the formation of land and sea breezes.

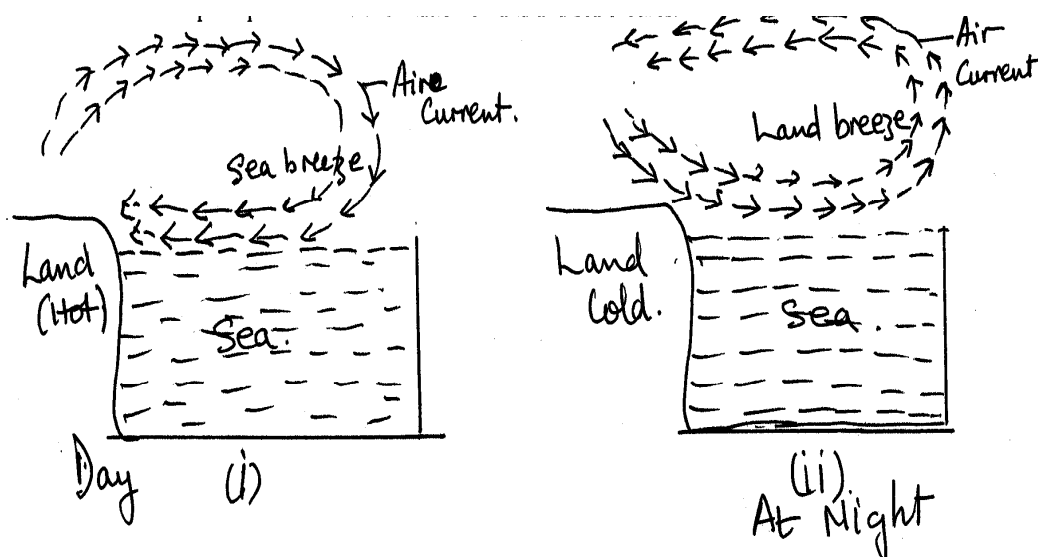


Fig. 8.4

Along the coastal regions we usually observe breeze flowing from the sea at day time which is always reversed in the night to constitute the land breeze.

During the day, the sun heats up both the land and the water. But as a result of the difference in the specific capacities of the land and water, the land is hotter than the water. Thus warm air rises up and its place taken up by the colder sea breeze (Fig. 8.4(i)).

During the night the land cools faster than the water. Thus the warm air above the water rises up and is replaced by the cold air from the land, thereby creating the land breeze (Fig 8.4 (ii)).

### Example 8.1

Which of the following position in a room will be reasonable for anyone to place an air conditioner

- at a height near the ceiling of the room?
- at a height closes to the floor of the room?

Explain your choice.

### 3.3 Newton's Law of Cooling

You would have observed that when a hot body is left in the air it cools down. This can occur under natural convection or forced convection. It cools naturally when the air is still. But when there is a steady draught, it can be cooled under what we call forced draught – as in ventilated cooling in a draught. Newton propounded the law of cooling which is satisfactory for all temperature excesses.

**Newton’s law of cooling states that the rate of loss of heat by a hot body is proportional to the temperature difference between the hot body and its surroundings.**

Suppose a body is at a temperature of  $\theta^{\circ}\text{C}$  and is allowed to cool in an environment of temperature  $\theta_0^{\circ}\text{C}$ , Newton’s law stipulates that:

$$\frac{Q}{t} = k (\theta - \theta_0) \dots\dots\dots (8.1)$$

or  $-\frac{Q}{t} = k (\theta - \theta_0) \dots\dots\dots (8.2)$

k is the constant of proportionality whose value depends on two factors (the negative sign shows that heat is lost to the surrounding):

- The nature of the exposed surface of the material – surface emmissivitiy e
- It’s surface area A

$$\therefore -\frac{Q}{t} = eA (\theta - \theta_0) \dots\dots\dots (8.3)$$

Many scientists have actually worked on this Newton’s law of cooling. Preston, Dulong and Petit and Lorentz are examples of such people. The summary of their findings have shown that:

- For forced convection in a strong draught Newton’s law of cooling prevails, where the rate of loss of heat is proportional to temperature excess

$$\therefore -\frac{Q}{t} = \infty (\theta - \theta_0) \dots\dots\dots (8.4)$$

- For natural convection in still air, the five-fourth power law predominates. That is the rate of loss of heat is proportional to the (temperature excess)<sup>5/4</sup>

$$\therefore -\frac{Q}{t} = \infty (\theta - \theta_0)^{5/4} \dots\dots\dots (8.5)$$

It is customary to use Newton’s law of cooling for heat loss in Calorimetry experiments.

## 4.0 CONCLUSION

In this unit, we have learnt that conduction does not take place in fluids (liquids and gases). In fluids the mode of transfer of heat that takes place is convection. This is the mode by which the molecules of the medium carry the heat energy from hotter region to the region to the colder region of the fluids.

We used the principle of expansion, which involves decrease in density of the medium, and Archimedes' Principle to explain convection in fluids. Newton's law of cooling was used to quantify the rate of loss of heat under natural or forced condition, which is proportional to the excess temperature of its temperature and its surrounding temperature. In the next unit we shall consider radiation as the third mode of transfer of heat in matter.

## 5.0 SUMMARY

In this unit you have learnt:

- Conduction does not take place in fluids;
- Heat is transferred in fluids (liquids & gases) by convection;
- There are natural and forced convection in fluids;
- Decrease in the molecules of fluids in the hotter region constitutes the convective current in the fluids due to the expansion of the molecules;
- Convection involves the material medium in the transfer of heat in fluids;
- Newton's law of cooling may be used to explain loss of heat by convection under natural and forced condition; and
- Under the natural convection the five-fourth law of Newton's law predominates whereas in the forced convection rate of loss of heat is proportional to only the excess temperature.

### ANSWER TO SELF ASSESSMENT EXERCISE 1

Refer to Text in Section 3.1.

### ANSWER TO SELF ASSESSMENT EXERCISE 2

Refer to section 3.2.2 of unit 8.

## 6.0 TUTOR-MARKED ASSIGNMENT

1. What is the difference between natural convection and forced convection?
2. With the aid of diagrams how would you show convection of heat in:
  - (i) A liquid?
  - (ii) Air?
3. In most supermarket stores you may discover that the deep freezer, in which the frozen commodities such as chicken, fish, meat, shrimps, etc are displayed, could be left open without closing them. Explain why this action is advantageous to the storekeeper.
4. The figures below represent the temperature of a cooling calorimeter at different times.

Time in minutes	0	1	2	3	4	5	6
Temperature in °C	45.0	33.0	26.1	21.7	19.1	17.4	16.5

Use a graph sheet to plot the graph of time against the temperature where time is the vertical axis and temperature the horizontal axis. Determine the rate of fall of temperature at 2 min.

## 7.0 REFERENCES/FURTHER READING

- Awe, O. and Okunola, O.O. (1986). *Comprehensive Certificate Physics*, Ibadan: University Press.
- Ference, M. (Jnr.), Lemon, H.B. and Stephenson, RJ (1970). *Analytical Experimental Physics*, Chicago: The University of Chicago Press.
- Feynman, R.P., Leighton, R.B. and Sands, M (1971). *The Feynman Lectures on Physics*, California: Addison-Wesley Publishing Company Limited.
- Flowers, B.H. and Mendoza, E (1970). *Properties of Matter*, London: John Wiley and Sons Limited.
- Noaks, M.A. (1963). *New Intermediate Physics*, Canada: Macmillan and company Limited.



Soars, F.W., Zemansky, M.W. and Young, H.D. (1980). *College Physics*. London: Addison-Wesley Publishing Company.

Tyler, F. (1966). *Heat and Thermodynamics*. London: Edwards Arnold Publisher Limited.

Wilkinson, J. (1983). *Essentials of Physics*, Australia: Macmillan Education Publishers.

Zemansky, M.W. (1968). *Heat and Thermodynamics*. New York: McGraw-Hill Book Company.

## UNIT 4 RADIATION

### CONTENTS

- 1.0 Introduction
- 2.0 Objectives
- 3.0 Main Content
  - 3.1 Nature of Radiation
    - 3.1.1 Properties of Radiation
    - 3.1.2 Detecting Heat Radiation
  - 3.2 Black Body Radiation
  - 3.3 Prevost's Theory of Heat Exchange
  - 3.4 Stefan-Boltzmann Law of Radiation
  - 3.5 Practical Application of Transfer of Heat
- 4.0 Conclusion
- 5.0 Summary
- 6.0 Tutor-Marked Assignment
- 7.0 References/Further Reading

### 1.0 INTRODUCTION

So far in this second module, we have learnt about the first two modes of transfer of heat in matter. We observed that conduction of heat is effectively done through solids. However, some of these solid materials could be described as good conductors of heat i.e. metals while some are classified as bad conductors of heat. We used the property, thermal conductivity of each material to do this. We also observed that conduction of heat in fluids (liquids and gases) does not occur, instead, convection of heat predominates among fluids. Consequently, these two modes of transfer of heat require material medium before they take place. The third mode of transfer of heat is Radiation which we will now consider in this unit.

In this unit we would examine the nature of radiation of heat, its properties, how it can be detected and examine the laws governing the radiation of heat.

### 2.0 OBJECTIVES

At the end of this unit, you should be able to:

- explain the nature of radiation of heat
- state the properties of heat radiation
- detect heat radiation
- explain the meaning of black body radiation
- state Prevost theory of heat exchange

- state Stefan-Boltzmann law of radiation
- solve problems on radiation of heat.

### 3.0 MAIN CONTENT

#### 3.1 Nature of Radiation

**Have you ever sat near an oven or campfire before? How would you explain the heat transferred to you? Is it by conduction or convection?** Remember what is between you and the source of heat is air. So, the idea of using conduction is ruled out. Again you recall that it is by the rising of hot air around the oven that heat is being transferred. But you are not above the source of heat but you are by the side. Hence, we cannot use the concept of convection to explain how the heat travels to you.

Now let us consider another example:

**Have you ever considered how the heat from the sun comes to the earth?**

The planet earth is many kilometers far away from the sun. The heat energy has to travel through empty space to reach the earth's atmosphere. Hence transfer of heat from the sun to the earth's atmosphere is mainly by what we describe as radiation.

*Then now you may ask: what is Radiation?*

Radiation is a way of heat transfer which does not require a material medium. This is in contrast to conduction or convection which needs a material medium to convey the heat energy.

Radiant energy consists of electromagnetic waves which travel with the speed of light. Radiation from the sun consists of the light and the ultra violet and infrared heat waves. All these travel with the speed of light.  $3.0 \times 10^8$  m/s.

##### 3.1.1 Properties of Radiation

Similar to light radiation, the study of which comes under waves and wave phenomena, heat radiation has the following properties:

- It can be reflected
- It can be refracted
- It can be diffracted
- It can be polarized

- It can produce interference
- It can be absorbed

Like light energy, it is in form of electromagnetic waves. However, its wavelength is longer than those of red light.

Heat radiation, which is invisible, is therefore called infrared radiation. The wave length of light waves range from  $4 \times 10^{-7}\text{m}$  (400nm) in violet to  $7.5 \times 10^{-7}\text{m}$  (750nm) in red. Whereas infrared radiation ranges from 750nm to about 100.00nm.

Although, most objects emit heat radiation in the invisible part of their spectrum or range of wavelengths, some very hot objects such as the sun emit heat radiation in the visible part of their spectrum.

### 3.1.2 Detecting Heat Radiation

Experiments have shown that dull or black surfaces are the best radiators and absorbers of heat radiation respectively. However, bright, shiny, polished or silvery surfaces are the worst radiators and absorbers of heat radiation. *But the question arises is: How do we detect heat radiation?*

Naturally our skins are capable of detecting heat radiation but a more sensitive and reliable instrument that is more commonly used to detect heat radiation is the THERMOPILE.

A thermopile is a series of arrangements of thermocouples made up of two dissimilar metals such as Bismuth (Bi), Antimony (Ag). Such arrangement can be used to detect and to give a rough measurement of the intensity of heat radiation.

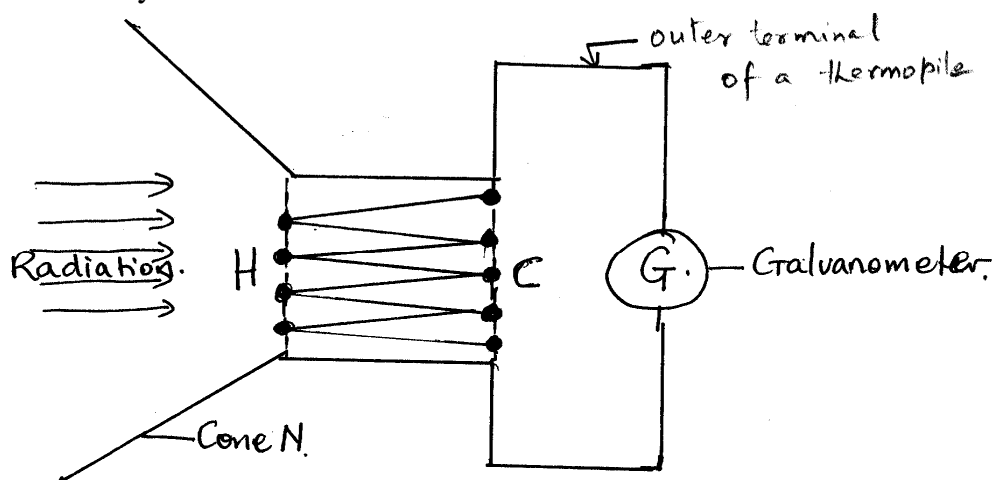


Fig. 9.1: A Thermopile

Refer to fig. 9.1. An arrangement H, made up of Bismuth-Antimony junctions are blackened so that any heat radiation falling on them warms up the junctions. A cone N is fitted on this end of the thermopile to prevent any stray radiation affecting these junctions. The other set of bismuth-antimony junctions C are silvered and remain cold or at a lower reference temperature C is shielded from the direct radiation.

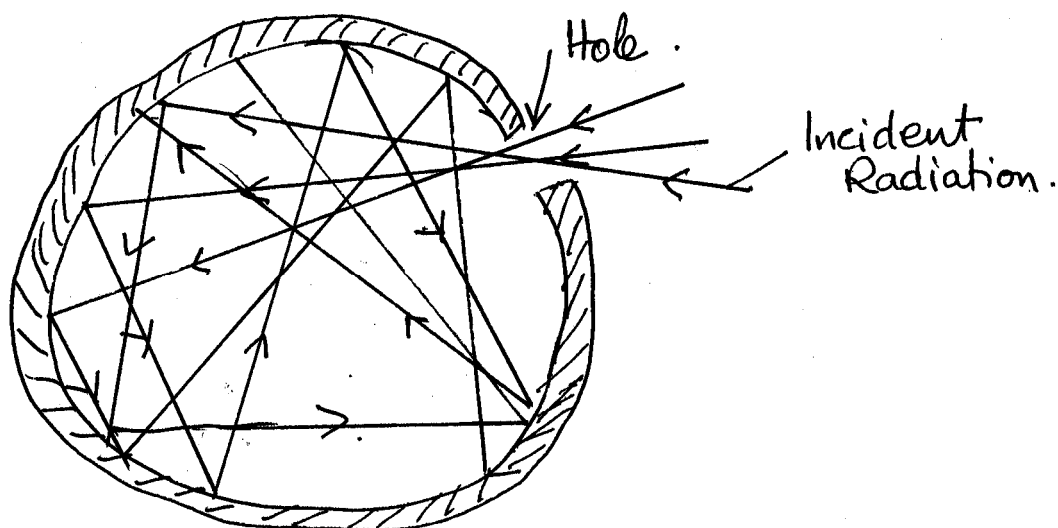
The thermo-electric emf developed produces a deflection on a sensitive galvanometer G, connected to the outer terminals of the thermopile. The deflection is a measure of the intensity of the heat radiation. When

calibrated, the actual intensity of heat radiation can be measured.

### 3.2 Black Body Radiation

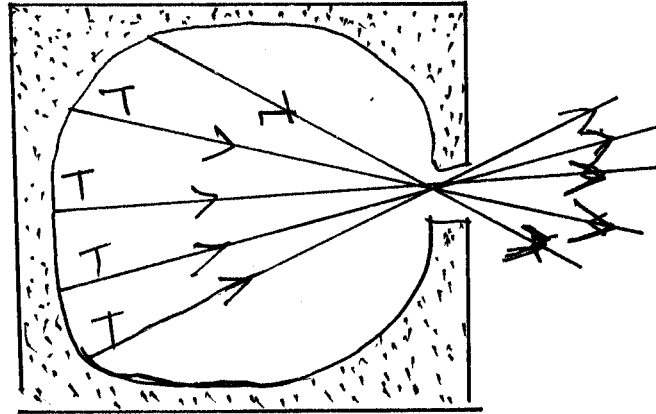
You will recall that a black body is the best radiator or absorber of heat radiation that falls upon it. A perfectly black body is therefore defined as one which emits every wavelength with the maximum energy for each wavelength for the particular temperature of the body. This black body is also known as an ideal radiator. A good example of black body is a ceramic-lined closed container with a hole in it. It may also be empty tin with a hole punched on the lid.

Any radiation which enters the hole is reflected several times round the inside surface and tends to be trapped inside it (fig. 9.2).



**Fig. 9.2: Black Body Absorber at Temperature T**

The absorber inside a black body may be silvery so that the reflection is high. With several reflections and absorption, the hole looks black. Since a good absorber of radiation is a good radiator, we can see that a hole in a closed container is also a black radiator (fig. 9.3).



**Fig. 9.3: Black Body Radiator**

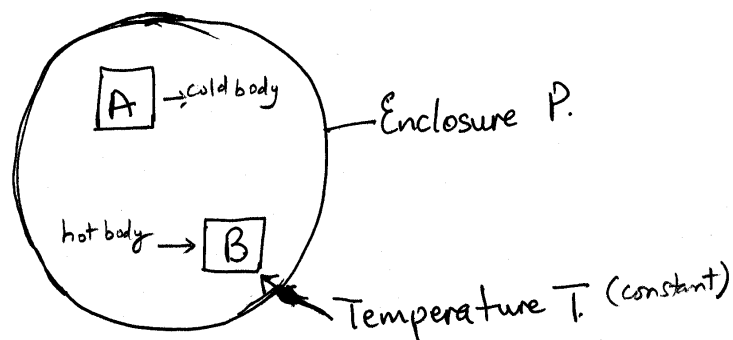
The inside is ceramic-lined and blackened to reduce quickly any reflected radiation and it is heated to a high temperature in a furnace or heat chamber. It should be noted that the radiation from a perfectly black body depends only on its temperature. It does not depend on the nature of the surface inside. Black body radiation is thus also called temperature radiation.

Non-black body radiators such as the hot filament of an electric lamp, may have some wavelengths of lower intensity compared with those emitted by a perfectly black body at the same temperature.

### 3.3 Prevost's Theory of Heat Exchange

In the last section, you have studied about black body. Now, you will learn about Prevost's theory. *In simple words, it states that when an object is at constant temperature or is in thermal equilibrium, it is losing and gaining heat at equal rates.*

Let us consider an enclosure P at constant temperature T. Inside this enclosure are two objects A and B. A is cold while object B is hot.



**Fig. 9.4**

Temperature T is however greater than the temperature of cold body  $T_A$  and less than the temperature of the hot body  $T^B$ .

$$T_B > T > T_A$$

At first, body A receives more radiation falling on it from B that it emits. Consequently, the temperature of A rises i.e. it warms up. Also, body B emits more radiation than it receives from A, hence the temperature of B decreases i.e. it cools down. Eventually, the equilibrium temperature T is attained. At this temperature both bodies are emitting and absorbing radiation at the same rate. The above process illustrates exchange of heat through radiation of bodies at different temperatures to reach a thermal equilibrium as opposed to what happens if they were to be in contact. However, if body A is a black body, then at temperature T, it radiates an appreciable amount of that heat at the same rate. If B is however a silvery surface, then, at temperature T, it radiates and absorbs less heat than A.

### 3.4 Stefan-Boltzmann Law of Radiation

Stefan found by experiment, while Boltzmann showed theoretically, that the total rate of radiation emitted per unit area by a perfectly black body was proportional to the fourth power of its absolute temperature (T) in Kelvin.

$$\frac{E}{tA} \propto T^4 \dots\dots\dots (9.1)$$

$$\therefore \frac{E}{tA} = \sigma T^4 \dots\dots\dots (9.2)$$

- Where, E = total heat energy emitted
- t = time of emission
- A = total surface area
- T = absolute temperature
- $\sigma$  = constant known as Stefan constant

The value of  $\sigma = 5.7 \times 10^{-8} \text{ Wm}^{-2}\text{k}^{-4}$ .

For any other body or surface different from a black body

$$\frac{E}{tA} = e\sigma AT^4 \dots\dots\dots (9.3)$$

or  $\frac{E}{tA} = e\sigma AT^4$

where,  $e$  = emissivity of the surface ( $e$  is a number characterizing the emitting properties of a particular surface).

But, the rate of emission is power, which can be represented as:

$$\frac{E}{t} = \text{Power } P \dots\dots\dots (9.4)$$

$$\therefore P = eA \sigma T^4 \dots\dots\dots (9.5)$$

If a black body X is placed inside an enclosure at a constant temperature  $T_o$ , then X will eventually reach the temperature  $T_o$ . From Prevost’s theory of heat exchanges, X receives from the enclosure as much radiation as it emits, which is  $\sigma AT_o^4$ .

If X is initially at temperature T inside an enclosure, the net heat per second radiated by X is

$$P = e\sigma A(T^4 - T_o^4) \dots\dots\dots (9.6)$$

**SELF ASSESSMENT EXERCISE**

A thin square steel plate 10 cm on a side is heated in a blacksmith forge to a temperature of 800°C. If the emissivity is unity, calculate the total rate of radiation of energy?

**3.5 Practical Application of Transfer of Heat**

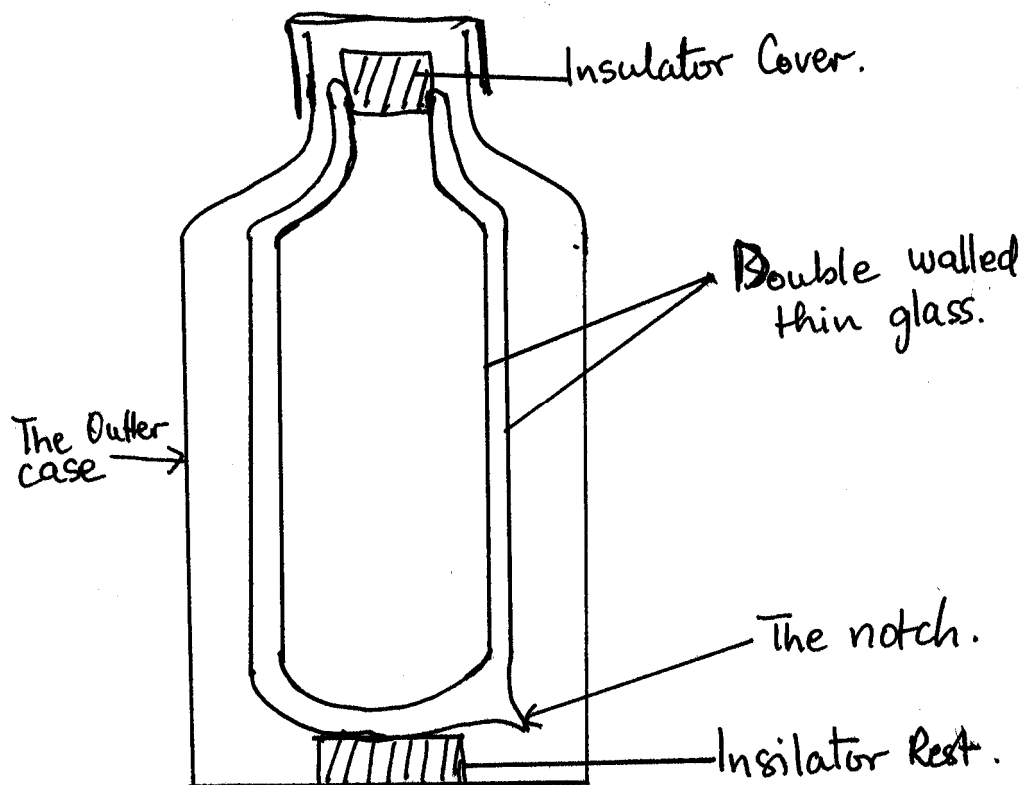
When we talk about the modes of transferring heat, we also need to consider their practical applications. Let us now discuss some of these important practical applications.

Some of the practical applications include: the screening action of clouds, the green house and the “thermos” flask. Here, you will learn about the “thermos” flask fully to show how the knowledge of conduction, convection and radiation has been used to keep materials at constant temperatures without loss of heat.

**The Thermos Flask**

The thermos flask was originally designed for the purpose of storing liquefied gases. But now it is used for maintaining the temperature of hot and cold liquids for long periods. Some have been designed nowadays to keep hot or cold solid food as pack for lunch or dinner.





**Fig. 3.5: The Thermos Flask**

Basically, the flask is made up of double-walled thin glass. The space in between the flask is evacuated to create a vacuum between the walls of the glass. If you examine a broken flask you will observe a small protruding notch at the bottom. This is where the glass was sealed off after creating the vacuum with the glass walls.

The open end of the flask is covered with a cork stopper or a plastic cover, which are non-conductors of heat. The double walled vacuum flask is sealed again in an insulator in the entire case containing the flask.

The evacuated space of the flask is to prevent loss of heat by conduction and convection, which require material medium.

In order to minimize loss or gain of heat by radiation, the surfaces facing the evacuated space are covered with silver. Thus, radiant heat from the hot liquid is reflected back at the outer wall. If cold liquid is placed inside the flask, heat radiation from the surrounding is reflected back from the silvered face of the inner wall. Consequently, any radiant heat entering the vacuum space is accordingly arrested.

## 4.0 CONCLUSION

In this unit, you have learnt about the third mode of transfer of heat by radiation. This mode of transfer of heat does not require any material medium. Radiant energy is electromagnetic in nature. It is detected and measured by the thermopile. We also learnt that black bodies are good absorbers and emitters of radiant heat energy. Whereas silvery and shiny surfaces are good reflectors of radiant energy. Prevost's theory of heat exchanges was used to explain how thermal equilibrium is reached through radiation between two bodies at different temperatures. Finally, Stefan Boltzmann law of radiation was used to quantify the rate of emission of radiant energy per area as being proportional to the fourth power of its absolute temperature. We shall now turn our attention to the properties of materials in the next module.

## 5.0 SUMMARY

In this unit we have learnt:

- the concept of radiation of heat as a mode of heat transfer;
- that the radiant heat energy is electromagnetic in nature and this mode of transfer does not require a material medium;
- that radiant heat energy could be detected and measured by the thermopile;
- the concept of black body in terms of its ability to absorb or emit heat energy;
- that a black body is a good absorber and a good emitter of heat;
- that more exactly, a black body is one whose radiation depends on its temperature;
- how Prevost theory of heat exchanges produces thermal equilibrium between two objects at different temperature;
- how Stefan-Boltzmann law of radiation is used in solving problems on radiation of heat energy; and
- that the study of black body radiation is a prelude to the study of quantum theory which is part of your later physics course.

## ANSWER TO SELF ASSESSMENT EXERCISE

Total surface area =  $2 \times 10^{-4} \text{m}^2$

Temperature =  $800^\circ\text{C} = 1073\text{K}$

From, Eq. 9.6,

$$P = \sigma eAT_o^4$$

Inserting these values in Eq. 9.6 above,

$$\sigma = 5.7 \times 10^{-8} \text{Wm}^{-2}\text{k}^{-4}$$

$$e = 1$$

$$A = 2 \times 10^{-4} \text{m}^2$$

$$T = 1074 \text{K}$$

We get,

$$\begin{aligned} \therefore P &= 5.7 \times 10^{-8} \frac{\text{W}}{\text{m}^2 \text{K}^4} \times 1 \times 2 \times 10^{-4} \text{m}^2 \times (1073)^4 \text{K}^4 \\ &= 5.7 \times 10^{-8} \times 1 \times 2 \times 10^{-4} \times (1073)^4 \text{W} \\ &= 5.7 \times 10^{-8} \times 2 \times 10^{-4} \times (1.073 \times 10^3)^4 \text{W} \\ P &= 15.12 \text{W} \end{aligned}$$

The concept of black body radiation will be revisited again at a higher level of your study of physics. Then you will learn the importance and the laws of black body radiation, which led to the development of the quantum theory of heat radiation.

## 6.0 TUTOR-MARKED ASSIGNMENT

- Describe the nature of thermal radiation. How is thermal radiation detected and measured?
- State the
  - Provost's theory of heat exchanges in radiation of heat.
  - Stefan-Boltzmann law of radiation.
- A radiant wall heater black body radiator is a silica cylinder 1.0m long and radius 0.5mm. It is rated at 1KW. If the room temperature is 300K, estimate the working temperature of the heater, stating any assumptions.  
(Stefan constant =  $5.7 \times 10^{-8} \text{Wm}^{-2} \text{K}^{-4}$ ).

## 7.0 REFERENCES/FURTHER READING

- Awe, O. and Okunola, O.O. (1986). *Comprehensive Certificate Physics*, Ibadan: University Press.
- Ference, M. (Jnr.), Lemon, H.B. and Stephenson, RJ (1970). *Analytical Experimental Physics*, Chicago: The University of Chicago Press, Chicago and London.
- Feyman, R.P., Leighton, R.B. and Sands, M (1971). *The Feyman Lectures on Physics*, California: Addison-Wesley Publishing Company Limited.
- Flowers, B.H. and Mendoza, E (1970). *Properties of Matter*, London: John Wiley and Sons Limited.

Noaks, M.A. (1963). *New Intermediate Physics*, Canada: Macmillan and company Limited.

Soars, F.W., Zemansky, M.W. and Young, H.D. (1980). *College Physics*. London: Addison-Wesley Publishing Company.

Tyler, F. (1966). *Heat and Thermodynamics*. London: Edwards Arnold Publisher Limited.

Wilkinson, J. (1983). *Essentials of Physics*, Australia: Macmillan Education Publishers.

Zemansky, M.W. (1968). *Heat and Thermodynamics*. New York: McGraw-Hill Book Company.

## UNIT 5 MOLECULAR PROPERTIES OF MATERIALS

### CONTENTS

- 1.0 Introduction
- 2.0 Objectives
- 3.0 Main Content
  - 3.1 Concept of Molecules
    - 3.1.1 The Concept of the Atom
    - 3.1.2 Measuring the Size of a Molecule
  - 3.2 Molecular Motion
  - 3.3 Molecular Mass
  - 3.4 Molecular Volume
  - 3.5 Molecular Density
- 4.0 Conclusion
- 5.0 Summary
- 6.0 Tutor-Marked Assignment
- 7.0 References/Further Reading

### 1.0 INTRODUCTION

Matter is a substance that has mass and occupies space. Thus solids, liquids and gases are forms of matter. Modern ideas will include plasma as the fourth form of matter. Plasma occurs when atoms are ionized at high temperatures. At very high temperatures, a substance consisting of positive ions and electrons is known as plasma. Under this section, we shall therefore concentrate on the properties of solids, liquids and gases.

Water exists in form of solid (ice block), liquid (water) and gas (steam). *The question you may ask is: What makes water to exhibit these three states of matter? Can we explain these three different states?*

By the time one tries to answer these questions for water and for other substances on earth, one is mainly looking at the properties of matter from the molecular point of view.

The theory about the existence of atoms and molecules form the backbone for the explanation of how matter exists in three states in terms of the molecular forces that exist between the molecules. That is, the type of molecular forces that exist among molecules in matter help us to explain why water can exist in solid, liquid and gas.

In this unit and in other units to follow, we shall study the properties of mater.

From your elementary science, you will recall that two kinds of property of matter are considered:

- (i) the physical properties and
- (ii) the chemical properties

We shall be concerned here with the physical properties of matter. Your various courses in chemistry, now and in the nearest future, will deal at length with the chemical properties of matter. The knowledge of chemical properties will include the knowledge of matter as an acid or a base. One is required to know how an element or a compound reacts with the litmus papers (red and blue), its reactions with water, air (oxygen), acids, bases etc.

With regards to physical properties, we shall be interested in the structure, size, mass, volume, density, elasticity, conduction of electricity, heat etc. However, in this unit we shall be concerned with the molecular properties of matter.

## 2.0 OBJECTIVES

At the end of this unit, you should be able:

- explain the existence of molecules in matter
- recognize the molecular motion in matter
- measure the size of a molecule of a chosen liquid
- deduce the density of a molecule from its mass and volume.

## 3.0 MAIN CONTENT

### 3.1 Concept of Molecules

The idea of the atomic nature of matter dates as far back as the time the Greek Philosophers proposed that the smallest indivisible unit of matter is the atom. They further stated that two or more atoms combine together to form a molecule. This is what constitutes the molecular nature of matter.

In the modern concept of the atom, we now know that the atom is divisible. Furthermore, it is not the smallest unit of matter as experiments have shown that the atom is made up of a nucleus and electrons, and the nucleus consists of positively charged protons and neutrons. Neutrons have no charges. Thus the protons, neutrons and electrons have been found to be fundamental particles of matter. The study of these particles will be done later. *Now, “Can you really imagine how small the atom of matter is?”*

### 3.1.1 The Concept of the Atom

If you take a piece of square yam, you may decide to start cutting it into equal pieces with a knife until such a time that you can no longer cut a piece into two. You may now use a fine blade and with the aid of a magnifying glass, you can continue to do the cutting. You may continue with this exercise under the microscope and ultimately under the electron microscope and you will find it extremely difficult to divide a piece of the yam. The limit of this divisibility is what the Greeks called the atom. Since, we now know that the atom is divisible, it is defined as the smallest unit of matter that can take part in a chemical reaction. As we said earlier, a combination of atoms constitutes a molecule.

In this section, we want to quantitatively ascribe a figure to the size of a molecule. In other words, we want to answer the question: *How big is the molecule of a particular substance?*

Is it possible to measure the average diameter of a molecule of a liquid such as paraffin or any other type of oil? To do this, we shall present you an analogue (example) on how to determine the diameter of a round bead without actually taking the bead and measuring it directly. We shall then use the analogue to demonstrate how to determine the diameter of a molecule, which you can not see with the naked eye. You can now imagine how small an atom is from this exercise.

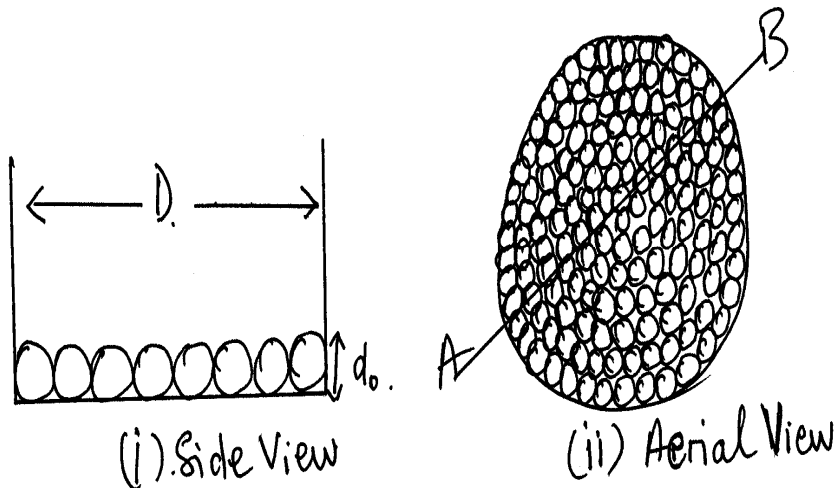
An atom may then be considered as the tiniest form of matter that can exist by itself. However, some of these atoms do not exist alone, two or more of them combine to form a molecule. Examples of such molecules are: oxygen ( $O_2$ ), Hydrogen ( $H_2$ ), Water ( $H_2O$ ), Sulphur ( $S_8$ ) and Phosphorous (existing as  $P_4$ ).

### 3.1.2 Measuring the Size of a Molecule

#### (a) An Analogue

In this measurement, we shall measure average diameter of a bead without measuring a bead physically. Now, let us discuss the procedure of experiment.

1. Collection of beads which are assumed to be spherical.
2. The beads are then spread in a Petridish such that they form a layer of beads as shown in figure (i) from the side view.



**Fig. 10.1**

Fig. 10.1 (i) shows the side view of the beads while fig. 10.1 (ii) shows the aerial view of the beads. It should be ensured that no bead is lying on top of the other.

3. In this position it is possible to estimate the volume occupied by the beads thus:

Volume (V) occupied = Circular Area x Height of Beads

$$V = \frac{\pi D^2}{4} \times d_o \dots \dots \dots (10.1)$$

where, D = diameter of the dish containing the beads  
 d<sub>o</sub> = average diameter of the beads since they are of one layer.

4. Now, the beads are poured into a measuring cylinder and the volume is read as Vcm<sup>3</sup>. The beads are shaken very well in the cylinder to make sure that they are well packed together in order to attain the minimum value for the volume.
5. The volume V measured under step (3) above is equal to the volume V in step (4) using the conservation principle of matter and its volume.

Hence,

$$V (\text{cm}^3) = \frac{\pi D^2}{4} \times d_o$$

$$\therefore d_o = \frac{4 V \text{cm}^3}{\pi D^2 \text{cm}^2}$$

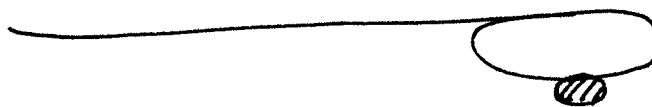


$$d_o = \frac{4V}{\pi D^2} \text{ cm} \dots\dots\dots (10.2)$$

Thus the average diameter of the bead,  $d_o$  can be determined by using Eq. (10.2). One may verify the validity of this determination by measuring some of the beads with a micrometer screw gauge and then finding the average value. This is the approach that will be used to determine the average diameter of the molecules of an oil, say paraffin.

**(b) Measuring the Molecular Size of Paraffin Oil**

Use a wire loop to pick up a drop of paraffin oil as shown in figure 10.2.



**Fig. 10.2**

Place the oil drop near a meter rule and with the aid of a magnifying glass, read the diameter of the oil drop and record it as  $d$ .

Using mathematical expression, the volume of this oil drop is

$$V_1 = \frac{4}{3} \pi \left( \frac{d}{2} \right)^3 \dots\dots\dots (10.3)$$

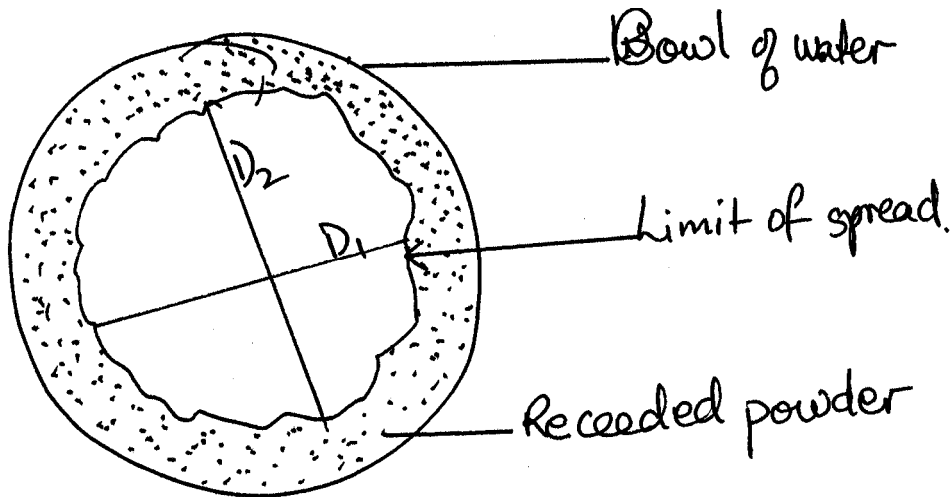
Where,  $d$  is the diameter of the oil drop and  $\frac{d}{2}$  is the radius of the oil drop.

Therefore, the Eq. (10.3) becomes

$$\therefore V_1 = \frac{4}{3} \pi \frac{d^3}{8}$$

$$V_1 = \frac{\pi d^3}{8} \dots\dots\dots (10.4)$$

Now take a large bowl of water and sprinkle some talcum powder over the surface. Allow the oil drop to spread on the surface of the water. As the oil spreads, the powder will be observed to be receding to the side of the bowl. This process of spreading should be given enough time.



**Fig. 10.3: Aerial View of Bowl**

NOTE: Let the spread be like a circle of diameter D such that

$$D = \frac{D_1 + D_2}{2} \dots\dots\dots (10.5)$$

When the liquid is well spread as shown in figure 10.3, record the average diameter D of the spread using Eq. (10.5). This corresponds to the situation where molecules are of one layer.

If the average diameter of the molecules is  $d_0$ , then the volume of the molecules which occupy one layer is

$$V_2 = \pi \left(\frac{D}{2}\right)^2 \times d_0$$

$$V_1 = \pi \frac{D^2}{4} \times d_0 \dots\dots\dots (10.6)$$

But this  $V_2$  is assumed to be equal to  $V_1$  which is  $\frac{\pi d^3}{6}$

i.e.  $V_1 = V_2 \dots\dots\dots (10.7)$

Using Eq. (10.7)

$$\therefore \frac{\pi d^3}{6} = \pi \frac{D^2}{4} d_0$$

We get the value of  $d_o$  as

$$d_o = \frac{\pi d^3}{6} = \pi \frac{4}{\pi D^2}$$

$$d_o = \frac{2}{3} \frac{d^3}{D^2} \dots\dots\dots (10.8)$$

*Now, Can you cross check your answer as you did with the bead?*

This is difficult question. There is no way you can cross check; however, the diameter of such measurement will be of the magnitude of  $10^{-10}$  m. If your measurement is in the neighbourhood, then it is correct and valid enough.

### 3.2 Molecular Motion

The molecules of matter are always in random motion, whether in the form of solid, liquid or gas. It is easy to demonstrate this concept by considering the motion of molecules in liquids and gases.

Consider the spread of the odour from a very palatable dish or you may consider the production of foul air from the corner of a room. The odour from these sources soon spread round to you. One may say that it is the wind that is responsible for the spreading. That may be true, but let us consider this experiment, which will show you what is described as molecular motion of matter.

The apparatus used in demonstrating molecular motion of matter is made up of a long glass tube with the two ends closed with the rubber bungs as shown in figure 10.4.

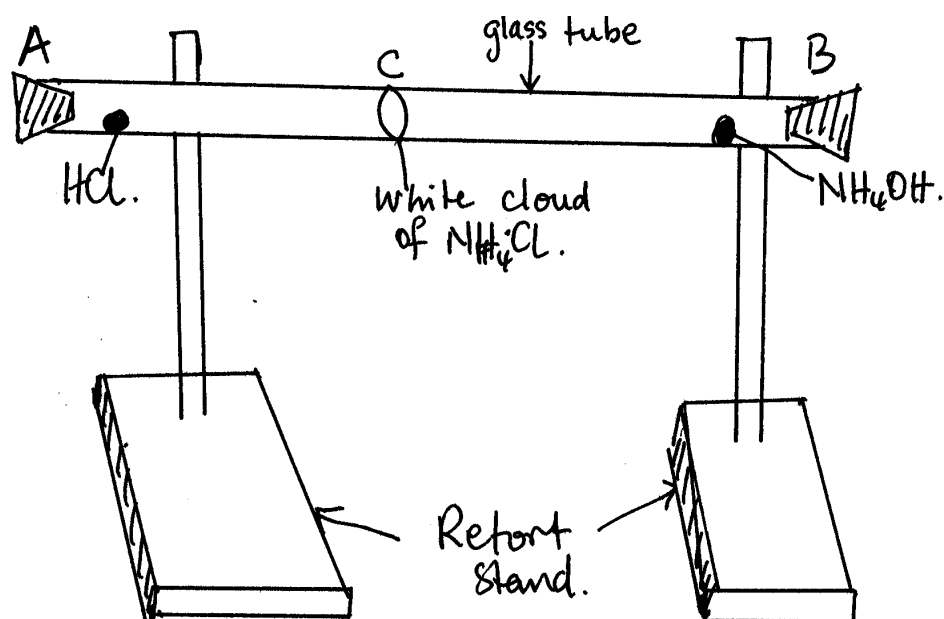
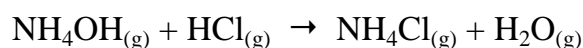


Fig. 10.4

A piece of absorbent cotton wool is soaked in concentrated hydrochloric acid (HCl) and then placed at one end A of the tube. Another piece of absorbent cotton wool is soaked in concentrated ammonium hydroxide (NH<sub>4</sub>OH) and then placed at the other end B of the glass tube. The two rubber bungs are used to close the tube. After some time, it will be observed that a white band of ammonium chloride will be formed in the tube. This has shown that the molecules of the two compounds have moved towards C to form ammonium chloride there.



Besides showing the molecular motion of these gaseous substances, it is possible to show the relative speed at which the gases move. It will be noticed that the lighter gas (NH<sub>3</sub>) ammonia, has moved a longer distance than the heavier one, hydrogen chloride (HCl).

Observe the relative position of the cloud to the two ends of the tube. This molecular motion may be described as diffusion. Diffusion takes place very much in nature. **It is defined as the process in which molecules move from area of high concentration to another area of low concentration until an equilibrium concentration is established within the system under consideration.** The state of equilibrium in this case does not necessarily mean that the molecules have become stagnant. It is a dynamic equilibrium. The fact still remains that the molecules are forever in motion. The diffusion of molecules of a solid in liquid or liquid molecules in another liquid may also be used to demonstrate the motion of molecules of matter. First, let us consider

solid molecules in a liquid. Place a copper sulphate crystal in a glass jar and then pour water into it very gently as shown in fig. 10.5

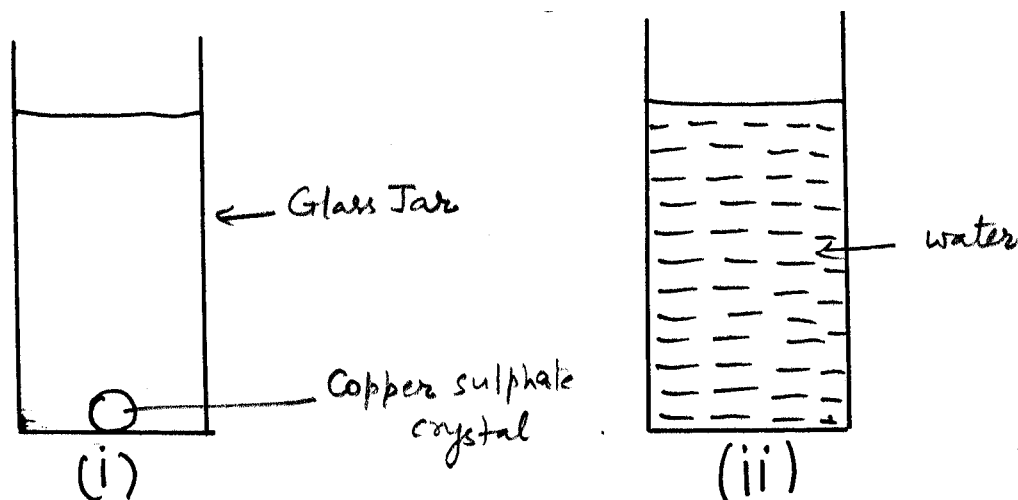


Fig. 10.5

Allow the jar and content to stay undisturbed for some days. It will be observed that a time will come when all the crystal would have diffused throughout the solution. This shows the motion of the solid molecules through the liquid water. It is also possible to pour water on a high concentrated copper sulphate solution or any other coloured solution as shown in figure 10.6.

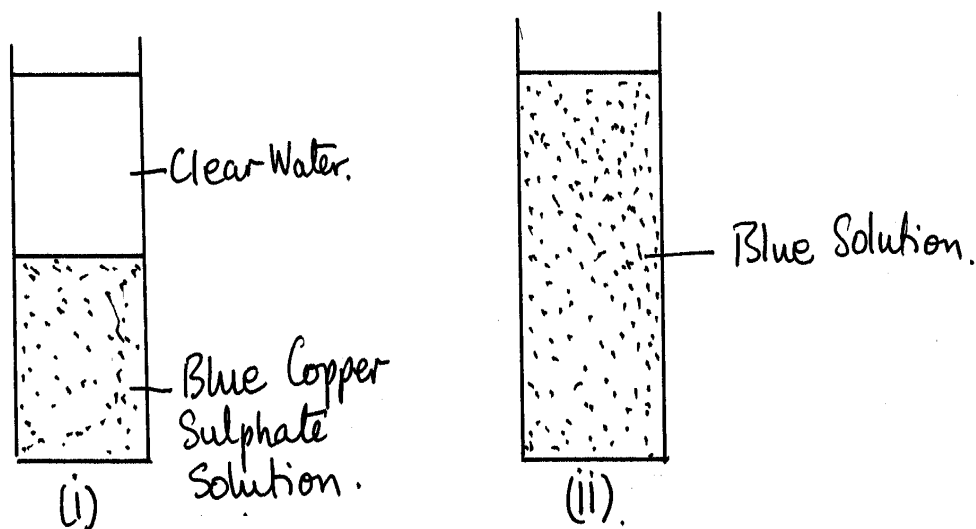


Fig. 10.6

- (i) Initially, there is a clear demarcation of water on top of the solution.
- (ii) After leaving the water and solution for a long time, it will be observed that the entire content becomes blue as a result of the motion of the molecules – the ever-moving molecules.

It is otherwise described as the Brownian motion. Recall also that molecular motion is described as being random.

### 3.3 Molecular Mass

You will recall from the definition of matter that it is anything that has mass and occupies space. Since our molecules have size, they also have mass. *The question that may arise is: How do we measure the mass of an atom or molecule?* This is done by the use of the mass spectroscopy. This technique has also enabled us to measure the masses of a proton, neutron and electron. The values are given as:

$$\begin{aligned} \text{Mass of proton} &= 1.673 \times 10^{-27} \text{kg} \\ \text{Mass of a neutron} &= 1.675 \times 10^{-27} \text{kg} \\ \text{Mass of an electron} &= 9.11 \times 10^{-31} \text{kg} \end{aligned}$$

### 3.4 Molecular Volume

The volume occupied by a molecule is the molecular volume. It is another property of matter. Experimentally, we have also found the volume occupied by the molecules of a substance such as that of a gas.

From Avogadro's hypothesis, we can describe the volume occupied by a mole of a gas – hence we have the molar volume.

The molar volume of gases at standard temperature and pressure (S.T.P.) is 22.4 liters.

A mole of gas contains  $6.0 \times 10^{23}$  molecules.

Hence we can deduce the volume of one molecule to be

$$= \frac{22.4 \text{ Vcm}^3}{6 \times 10^{23}} \text{ litres} = 3.73 \times 10^{-23} \text{ litres}$$

### 3.5 Molecular Density

The density of a substance is the mass of that substance per unit volume. Thus molecular density defines the density of a molecule i.e. the mass of molecule in kg per  $1\text{m}^3$  volumes.

It tells us how heavy or light the molecule is. Hydrogen molecule has been found to be the lightest gas on earth. Hence its molecular density is the smallest in value.

## 4.0 CONCLUSION

Matter is made up of atoms and molecules, which may exist in solid, liquid or gas. The atom is made up of negatively charged electrons and the nucleus, which consists of positively charged protons and neutrons that have no charges. Some matter exists as atoms while others are made up of molecules, which are combinations of two or more atoms. It has been shown that it is possible to measure the size of a molecule of a substance which is of the order of magnitude of  $10^{-10}$  m. Molecules of matter are forever in random motion when in liquid and gaseous states. In solid states, molecules are in fixed positions vibrating about a position. Associated with molecules of matter are their properties of mass, volume and density.

## 5.0 SUMMARY

In this unit you have learnt:

- About the atom as the smallest particle of matter that can take part in any chemical reaction,
- Two or more atoms combine to form a molecule,
- Matter exists in three states – solid, liquid and gas,
- The molecules of matter are forever in random motion,
- It is possible to determine the size of a molecule,
- The magnitude is of order of,  $10^{-10}$  m.
- The molecular density is obtained from the knowledge of the mass and volume of the molecule.

## 6.0 TUTOR-MARKED ASSIGNMENT

1. How would you determine the diameter of a given sample of oil? Discuss the basic assumptions involved in such a measurement.
2. Describe an experiment to show that matter is in constant motion.
3. Differentiate between atoms and nucleus.

## 7.0 REFERENCES/FURTHER READING

- Awe, O. and Okunola, O.O. (1986). *Comprehensive Certificate Physics*, Ibadan: University Press.
- Ference, M. (Jnr.), Lemon, H.B. and Stephenson, RJ (1970). *Analytical Experimental Physics*, Chicago: The University of Chicago Press.
- Feynman, R.P., Leighton, R.B. and Sands, M (1971). *The Feynman Lectures on Physics*, California: Addison-Wesley Publishing Company Limited.
- Flowers, B.H. and Mendoza, E (1970). *Properties of Matter*, London: John Wiley and Sons Limited.
- Noaks, M.A. (1963). *New Intermediate Physics*, Canada: Macmillan and company Limited.
- Soars, F.W., Zemansky, M.W. and Young, H.D. (1980). *College Physics*. London: Addison-Wesley Publishing Company.
- Tyler, F. (1966). *Heat and Thermodynamics*. London: Edwards Arnold Publisher Limited.
- Wilkinson, J. (1983). *Essentials of Physics*, Australia: Macmillan Education Publishers.
- Zemansky, M.W. (1968). *Heat and Thermodynamics*. New York: McGraw-Hill Book Company.



**MODULE 3**

Unit 1	Elastic Property of Materials
Unit 2	Moduli of Elasticity
Unit 3	Kinetic Theory of Gases and Applications
Unit 4	Density
Unit 5	Buoyancy – Archimedes' Principle

**UNIT 1 ELASTIC PROPERTY OF MATTER****CONTENTS**

1.0	Introduction
2.0	Objectives
3.0	Main Content
3.1	Concept of Elasticity
3.2	Hooke's Law
3.3	The Concept of Elastic Limit and Other Terms
4.0	Conclusion
5.0	Summary
6.0	Tutor-Marked Assignment
7.0	References/Further Reading

**1.0 INTRODUCTION**

As you know, when some objects are stretched or compressed by applying a force, their shapes change. But when the determining force is removed from the objects, the objects regain their original form or shape. Such objects are known as elastic objects.

Matter as a whole may be subjected to loads and forces. We may be able to see the effects of such load or force on matter. The example of stretching of a rubber shows where the effect is very obvious. The bridges are subjected to heavy loads but the effects of such loads are not very obvious. Thus the steel with which most bridges are built is usually subjected to all kinds of research in order to know how it can withstand the forces. The study of such a research in order to know it can withstand the forces. The study of such a research is referred to as the study of elasticity of the material.

In the beginning of this unit, we shall discuss about the elasticity. Then you will read about Hooke's law. Finally, you will learn about the concept of elastic limit and related terms: in the next unit we will discuss moduli of elasticity.

## 2.0 OBJECTIVES

At the end of this unit you should be able to:

- explain the term elasticity
- explain the elastic limit of a metal in the form of a wire
- define stress and strain
- state Hooke's law of elasticity
- solve problems on Hooke's law.

## 3.0 MAIN CONTENT

### 3.1 Concept of Elasticity

Elasticity is the property of a material to regain its original shape or form after removing the deforming force, or load provided the elastic limit is not exceeded.

There are certain terms used in connection with elasticity; stress and strain. Let us discuss briefly about these two terms. **The stress on a n elastic material is defined as the force exerted on the material per unit area.** It can also be expressed as:

$$\text{Stress} = \frac{\text{Force}}{\text{Area}} = \frac{F}{A} \dots\dots\dots (11.1)$$

The force is measured in Newton's (N) and the area is in meter square ( $\text{m}^2$ ) then the unit of stress is therefore Newton per meter square ( $\text{Nm}^{-2}$ ).

If an object has an original length of  $\ell$ , when it is stretch or compressed in such a way that it has an extension or compression value of  $e$ , then, the strain on the object is defined as

$$\text{Strain} = \frac{\text{Extension produced on the object}}{\text{The original length of the object}}$$

$$\text{Strain} = \frac{e}{\ell} \dots\dots\dots (11.2)$$

Stress is related to the force producing the deformation. Strain is related to the amount of deformation.

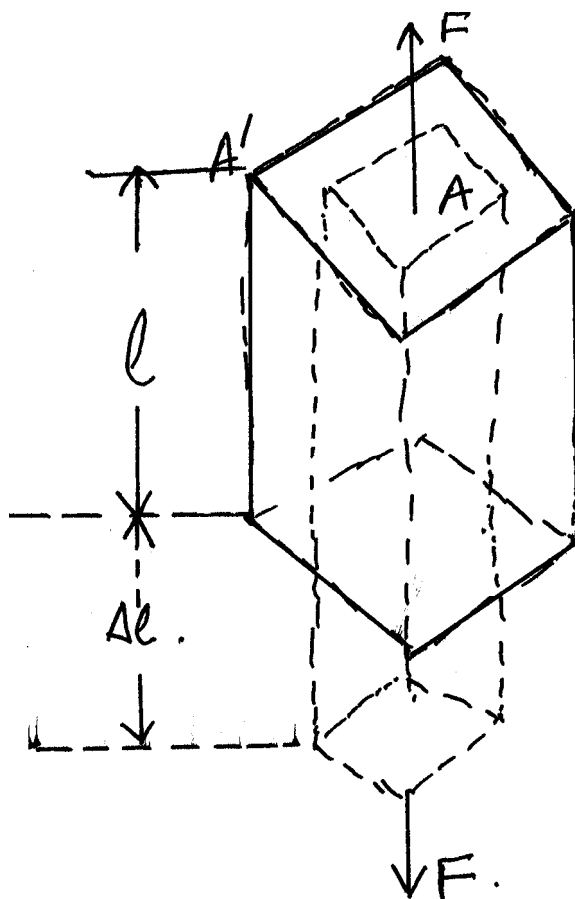


Fig. 11.1

Fig. 11.1 shows a typical deformation of a body subjected to a force  $F$  whose cross-sectional area  $A'$  changes to  $A$  and whose length is increased by  $\Delta l$ . Provided its elastic limit is not exceeded, the material goes back to the former state.

Materials such as Dough, Lead and Putty, for which elastic limit is small are called inelastic or plastic material. Steel is highly elastic because it recovers itself to its original position when the load or force is removed.

### 3.2 Hooke's Law

Consider a helical spring of original length  $l_0$  (fig. 11.2 (i)). When a weight is attached to it, it will be observed that the spring will be stretched through a distance  $e$ . By using slotted weight, we can vary the force  $F$  acting on the spring and with the aid of a ruler we can measure the extension  $e$  for each corresponding weight.

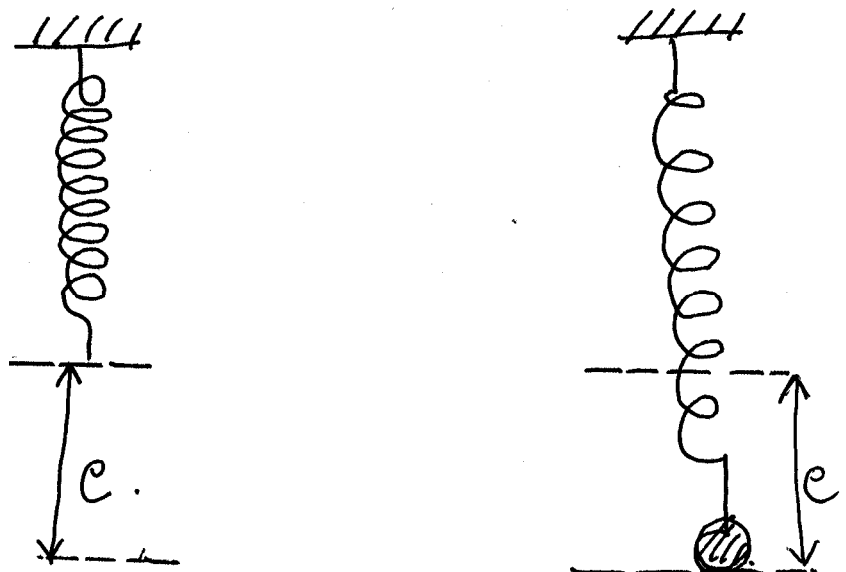


Fig. 11.2

When the various force ( $F$ ) are plotted against their corresponding extensions ( $e$ ) measured, a linear relationship is obtained as shown in fig. 11.3, that is, provided the elastic limit is not exceeded.

It is on the basis of this experiment that the British Scientist Robert Hooke formulated the law of elasticity which is known as Hooke's law.

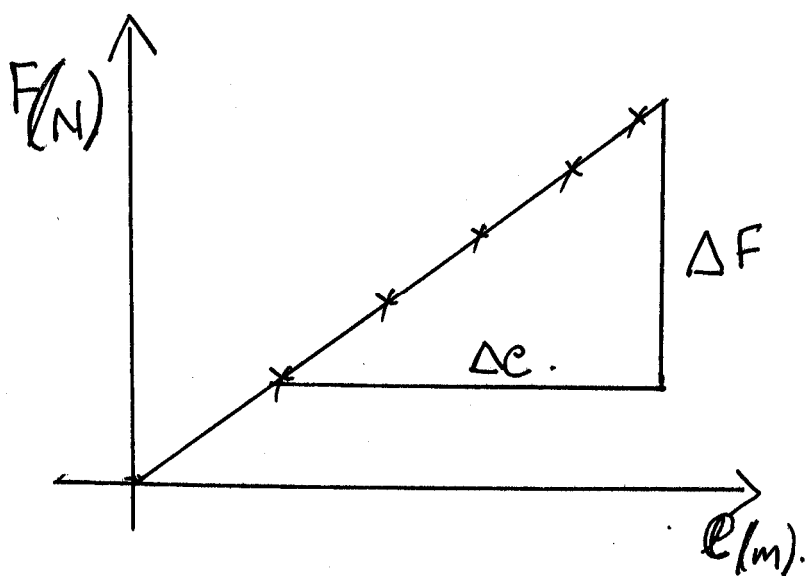


Fig. 11.3: A plot of Forces versus Extensions Measured

Hooke's law states that **the force applied on elastic material is directly proportional to the extension produced provided the elastic limit is not exceeded.**

$$\begin{array}{l} F \propto e \\ F = -ke \end{array}$$

Where  $k$  is a constant of proportionality usually referred to as the spring constant.  $K$  is a property of elastic material. The negative sign is to show the restoring ability of the material. Later a modified form of this law was given. According to which “within elastic limit, the stress on an elastic material is directly proportional to the strain produced in the material”.

Stress & strain  
 Stress =  $M$  strain

Where  $M$  is a constant. The constant is called a Modulus of elasticity of the material of the body.

### SELF ASSESSMENT EXERCISE

State Hooke’s law and describe an experiment to verify the law.

### 3.3 The Concept of Elastic Limit and Other Terms

We shall use the experimental set up in fig. 11.4 to show the concept of elastic limit, yield point and other terms used in the elastic property of matter. The apparatus is made up of two wires **P** and **Q**. Wire **P** is held taut by weight **A**. While Wire **P** carries a scale **M**. The second wire **Q** carry a vernier scale **V** is subjected to variation of forces **W**. The two wires **P** and **Q** are suspended from a common support **S**.

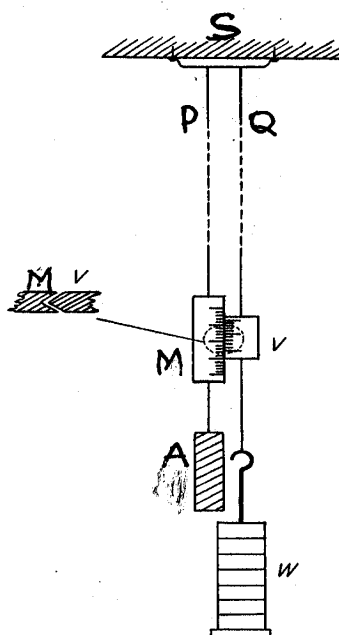


Fig. 11.4

If wire **Q** is loaded, the length of the wire increases. When it is off-loaded, it returns to its original position. If a material behaves this way, such a material is described as being elastic.

The load on wire **Q** is called the tensile force. When the wire is thus subjected to various tensile forces its corresponding extension ( $e$ ) can then be observed.

The graph of the force (**F**) against the extension ( $e$ ) can be plotted. A typical graph obtained from such an exercise is shown in fig. 11.5.

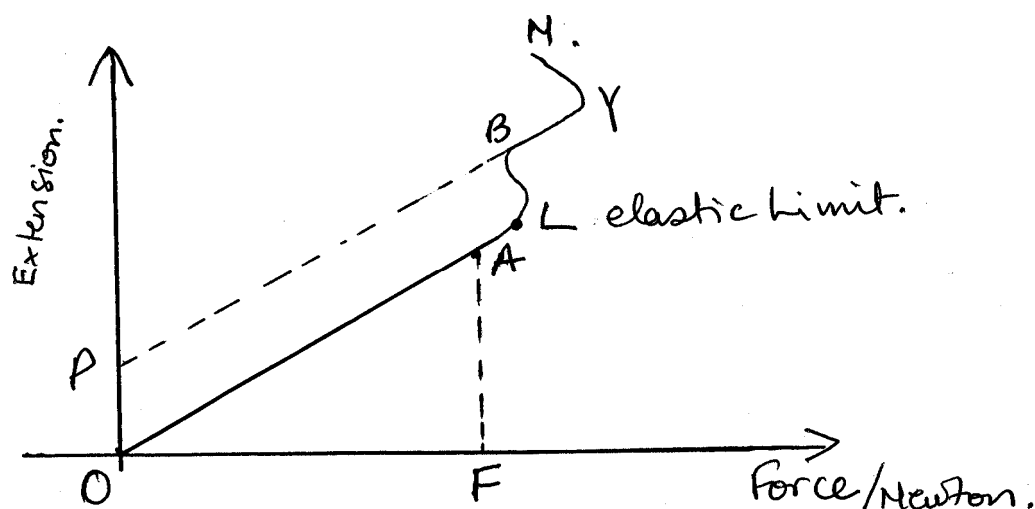


Fig. 11.5: Graph of Extension versus Force

Now let us discuss the shape of the graph obtained. It is made up of straight line **OA** followed by a curve **ABY** rising slowly at first and then sharply. Along and up to **L**, which is just beyond **A**, the wire is capable of returning to its original length when the load is removed. **A** is therefore the limit of proportionality. The force at **L** is the force of elastic limit.

Along **OL**, the metal is said to undergo changes called elastic deformation. Beyond **L**, the wire has a permanent extension as shown by line **OP**. When the force is at **B**.

Beyond **L**, the wire is no longer elastic. With more force the extension increases rapidly along the curve **ABY**. At **N**, the wire thins out and breaks.

### **The Yield Point**

For mild steel and iron, the molecules of the wire begin to slide across each other soon after the load (force) has exceeded the elastic limit. At this stage, the metal is described as being plastic as shown in the slight kink at **B** beyond **L** (fig. 11.5). This is the yield point of the wire.

The change from elastic to plastic stage is shown by a sudden increase in the extension. In the plastic stage, the energy gained by the stretched wire is dissipated as heat. Unlike the elastic stage, the energy is not recoverable when the load is removed.

As the load is increased further, the extension increases rapidly along the curve **YN**. The wire then becomes narrower and finally breaks. The breaking stress of the wire is the corresponding force per unit area of the narrowest section of the wire.

### **Ductile Substances**

Substances which lengthen considerably and undergo plastic deformation until they break are ductile substances. Examples of such substances are Lead (Pb), Copper (Cu) and Wrought Iron (Fe).

### **Brittle Substance**

When substances break just after the elastic limit is attained, then, such substances are said to be Brittle. Glass, high carbon steel brass, bronze and other alloys have no yield point.

## **4.0 CONCLUSION**

When a force is applied to a material it changes its shape. When the force is removed, the material regain its original sate, hen that object is said to be elastic. However, the amount of force applied to that object must be such that the elastic limit is not exceeded. If the force is applied in such a way that the object is permanently deformed, then we say that the elastic limit has been exceeded. Robert Hooke established the relationship between the force applied to a material and the extension produced within the elastic limit. The force applied per unit area of the material described the stress on the material. The ratio of the extension produced by the force and the original length of the material known as strain on the material. Substances are classified as being ductile or brittle depending on their behaviour when the elastic limit has been exceeded. A substance is said to be ductile if undergoes a plastic deformation and breaks. A substance is said to be brittle if it breaks just when it has exceeded its elastic limit.

## 5.0 SUMMARY

In this unit you have learnt that:

- A material is said to be elastic if when deformed by the application of a force and capable of regaining its original shape when the applied force is removed;
- The deformation can be in the form of change in length and shape;
- Robert Hooke showed that within the elastic limit, the force on a given length of wire is directly proportional to its extension ( $e$ );
- The yield point of an elastic material occurs when the load on it makes it to exceed the elastic limit and the material becomes permanently deformed or plastic;
- A material is described as being ductile when it undergoes a plastic deformation and then breaks;
- A material is described as being brittle if just when it is at its elastic limit any additional load makes it to break.

### ANSWER TO SELF ASSESSMENT EXERCISE

Refer to Section 3.2 of Unit 11. To verify the law, you can take a metallic spring, a scale, and pan to attach with the spring. Also take some weight to put into pan and note the corresponding extensions from the lower scale. Draw a graph between load applied and the extension. Then conclude the result and verify the law.

## 6.0 TUTOR-MARKED ASSIGNMENT

The extension in length of a spiral spring varies as different weights are suspended from it. The result of the experiment with the spiral spring is as shown below in tabular form:

<b>W(<math>10^{-2}</math>N)</b>	5	10	20	30	40	50	60
<b>Extension (cm)</b>	0.9	1.8	3.6	5.4	7.2	9.0	10.8

Plot the graph of weight versus the extension produced, and deduce the relationship between the weight and the extension. Determine the spring constant of the spiral spring.



## 7.0 REFERENCES/FURTHER READING

- Awe, O. and Okunola, O.O. (1986). *Comprehensive Certificate Physics*, Ibadan: University Press.
- Ference, M. (Jnr.), Lemon, H.B. and Stephenson, RJ (1970). *Analytical Experimental Physics*, Chicago: The University of Chicago Press.
- Feynman, R.P., Leighton, R.B. and Sands, M (1971). *The Feynman Lectures on Physics*, California: Addison-Wesley Publishing Company Limited.
- Flowers, B.H. and Mendoza, E (1970). *Properties of Matter*, London: John Wiley and Sons Limited.
- Noaks, M.A. (1963). *New Intermediate Physics*, Canada: Macmillan and company Limited.
- Soars, F.W., Zemansky, M.W. and Young, H.D. (1980). *College Physics*. London: Addison-Wesley Publishing Company.
- Tyler, F. (1966). *Heat and Thermodynamics*. London: Edwards Arnold Publisher Limited.
- Wilkinson, J. (1983). *Essentials of Physics*, Australia: Macmillan Education Publishers.
- Zemansky, M.W. (1968). *Heat and Thermodynamics*. New York: McGraw-Hill Book Company.

## UNIT 2 MODULI OF ELASTICITY

### CONTENTS

- 1.0 Introduction
- 2.0 Objectives
- 3.0 Main Content
  - 3.1 Young's Modulus
    - 3.1.1 Force in Bar Due to Contraction or Expansion
    - 3.1.2 Energy Stored in a Wire
  - 3.2 Bulk Modulus of Elasticity
    - 3.2.1 Bulk Modulus of a Gas – Isothermal Bulk Modulus
    - 3.2.2 Bulk Modulus of a Gas – Adiabatic Modulus
  - 3.3 Shear Modulus of Elasticity or Modulus of Rigidity
- 4.0 Conclusion
- 5.0 Summary
- 6.0 Tutor-Marked Assignment
- 7.0 References/Further Reading

### 1.0 INTRODUCTION

In the previous unit, you were introduced to the elastic properties of matter. You learnt about the law that governs the elastic nature of a material, most especially if it is a solid object. We have also observed that it is not only solid objects that are elastic or that can be subjected to stress and strain, what about liquids and gases?

Elastic nature of liquids is not very obvious as compared with that of gas. If you take a bicycle pump, close the end part with your finger very hard so that when you push down the piston air does not escape. Then push down the piston by applying force on the handle. The piston goes down through a considerable distance but when released the piston springs back to its original position. This shows the compressibility of the air molecules and their elastic nature.

Thus in considering the elastic nature of liquids and gases in this unit we shall embark on the other concepts of elasticity which involves the moduli of elasticity. These are the Young, Bulk and Shear moduli. Liquids and gases also experience stresses and strains when forces are applied on them. Besides, we would also consider the energy involved in the stretching of a wire.

## 2.0 OBJECTIVES

After studying this unit you should be able to:

- define Young's modulus of elasticity
- define Shear modulus of elasticity
- define Bulk modulus of elasticity
- relate Young's modulus with thermal expansion of a metal
- define energy stored in a stretched wire
- solve problems on moduli of elasticity.

For a given material, there can be different types of modulus of elasticity. Now in the subsequent sections, we will learn about these. It all depends upon the type of stress applied and the resulting strain produced. Let us discuss these facts.

## 3.0 MAIN CONTENT

### 3.1 Young's Modulus

When a force (F) is applied to the end of a wire of cross-sectional area A and having an initial length L, we define the tensile stress on the wire as the force per unit area.

$$\begin{aligned} \text{Tensile stress} &= \frac{\text{Force}}{\text{Area}} \\ &= \frac{F}{A} \dots\dots\dots (12.1) \end{aligned}$$

Where F is measured in Newton's (N) and Area is in meter-square (m<sup>2</sup>). Therefore the unit of tensile stress is Nm<sup>-2</sup>.

The cross-sectional area A of the wire is expressed as,

$$A = \frac{\pi D^2}{4} \pi r^2$$

Where, r is the radius of the cross-section and D is the diameter of the cross-section.

If on the application of the force F, the wire is extended by (e) then we would define its tensile strain as

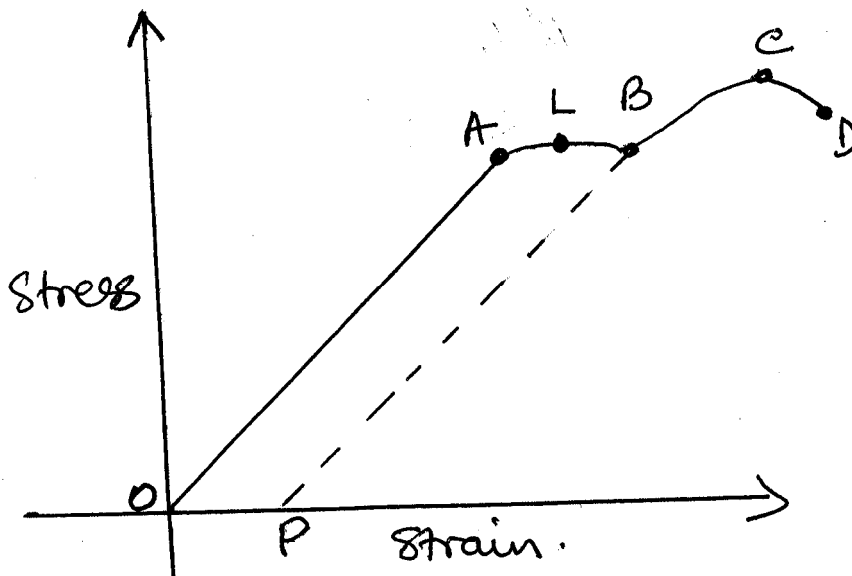
$$\begin{aligned} \text{Tensile strain} &= \frac{\text{extension}}{\text{initial length}} \\ &= \frac{e}{L} \dots\dots\dots (12.2) \end{aligned}$$

**SELF ASSESSMENT EXERCISE 1**

2kg mass is attached to the end of a vertical wire of length 2m with a diameter of 0.64mm and having an extension of 0.60m. Calculate

- (i) the tensile stress
- (ii) the tensile strain on the wire (take  $g = 9.8\text{m/s}^2$ )

Stress on a wire is plotted against the strain, a graph shown in fig. 12 is obtained.



**Fig. 12.1: Stress versus Strain**

The points and region on the graphs shows

- A = proportional limit
- L = elastic limit
- B = Yield point
- C = Breaking Stress
- D = wire breaks
- OL = elastic deformation
- BC = plastic deformation

From this graph, we shall define the Young's Modules of Elasticity symbolized as E.

Thus 
$$E = \frac{\text{Tensile stress}}{\text{Tensile Strain}}$$

$$E = \frac{F}{A} \div \frac{e}{\ell} \dots\dots\dots (12.3)$$

### Example 12.1

The Tensile stress and Tensile strain of a wire  $6.09 \times 10^7 \text{Nm}^{-2}$  and  $3 \times 10^{-4}$  respectively. Determine Young's Modules of the wire.

#### Solution

$$\begin{aligned} E &= \frac{\text{Tensile Stress}}{\text{Tensile Strain}} \\ &= \frac{6.09 \times 10^7 \frac{\text{N}}{\text{m}^2}}{3 \times 10^{-4}} \\ &= 2.03 \times 10^{11} \text{Nm}^{-2} \end{aligned}$$

The Young's Modulus =  $2.03 \times 10^{11} \text{Nm}^{-2}$

### 3.1.1 Force in a Bar Due to Contraction or Expansion

When an iron bar is heated and is prevented from contracting as it cools, experiments have shown that a considerable force is exerted at the ends of the bar.

It is possible for us to obtain the force exerted with the knowledge of Young Modules  $E$ , cross-sectional area  $A$ , the coefficient of linear expansion  $\alpha$  (linear expansivity) and the change in temperature due to the contraction or expansion,  $\Delta\theta$ .

From Eq. (12.3), you know that the force  $F$  is given by

$$\begin{aligned} E &= \frac{F}{A} \div \frac{e}{L} \\ \therefore E &= \frac{F}{A} \times \frac{L}{e} \\ \therefore F &= \frac{EAe}{L} \dots\dots\dots (12.4) \end{aligned}$$

Also, the coefficient of linear expansion is given as

$$\alpha \therefore \frac{\Delta L}{L\Delta\theta} = \frac{e}{L\Delta\theta}$$

$$\therefore e = \alpha L\Delta\theta \dots\dots\dots (12.5)$$

Substituting Eq. (12.5) in Eq. (12.4), we get

Hence  $F = \frac{EA}{L} \times \alpha L\Delta\theta$

$$F = EA\alpha\Delta\theta \dots\dots\dots (12.6)$$

**SELF ASSESSMENT EXERCISE 2**

A steel rod of cross-sectional area 2.0cm<sup>2</sup> heated to 100°C and then prevented from contracting when it cooled to 10°C. If linear expansivity of steel is 12 x 10<sup>-6</sup> k<sup>-1</sup> and Young Modules = 2.0 x 10<sup>11</sup>N/m<sup>2</sup>. Calculate the force exerted on contraction.

**3.1.2 Energy Stored in a Wire**

As you know that work done is defined as the product of the force and the distance moved by the force

i.e. Work done = Force x distance

For a given wire, the work in stretching it is given by

$$\begin{aligned} \text{Work done} &= \text{Average force} \times \text{extension} \\ &= \left(\frac{F}{2}\right) \times e \end{aligned}$$

But now you may ask: why we are using the average force rather than absolute force?

This is because of the fact that the force increases from zero to a given value, provided the elastic limit is not exceeded. Therefore the amount of work done in stretching a wire, or the amount of energy stored in the wire is given by

$$W = \frac{Fe}{2} \dots\dots\dots (12.7)$$

The energy stored is the gain in molecular Potential Energy of the molecules due to their displacement from their mean positions.

The energy store could be expressed in terms of Young Modulus. Now, substitute the value of F from Eq. (12.4) in Eq. (12.7), we get

$$W = \frac{1}{2} \times \left( \frac{EAe}{L} \right) \times e$$

$$W = \frac{1}{2} \times \frac{EAe^2}{L} \dots\dots\dots (12.8)$$

**SELF ASSESSMENT EXERCISE 3**

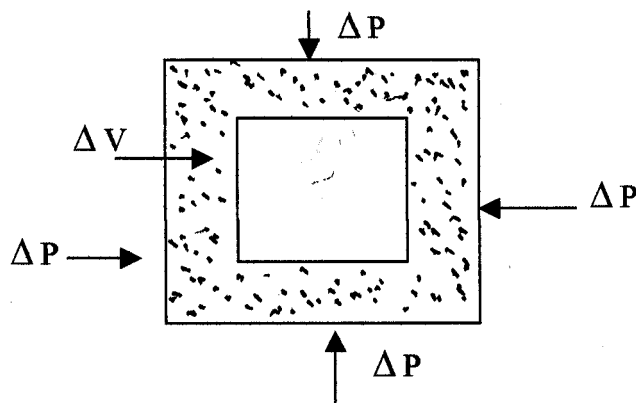
A vertical wire, suspended from one end is stretched by attaching a weight of 20N to the lower end. If the weight extends the wire by 1mm. calculate the energy gained.

**3.2 Bulk Modulus of Elasticity**

Meanwhile, you would have observed that we have always been talking about elasticity in terms of solids (i.e. wire). What about liquids and gases? While Young Modulus of elasticity is associated with solid objects, the bulk modulus deals with liquids and gases.

When a liquid or gas is subjected to an increase pressure, the substance contracts. A change in the bulk thus occurs. The bulk strain is defined as the change in volume ( $\Delta V$ ) of a gas (or liquid) to the original volume V.

$$\text{Bulk Strain} = \frac{\text{Change in volume of gas or liquid}}{\text{Original volume of gas or liquid}}$$



**Fig. 12.2: Bulk Stress & Bulk Strain**

Since the change in volume is  $-\Delta V$

And the original volume is  $V$ ,

Therefore the, Bulk Strain =  $\frac{-\Delta V}{V}$  ..... (12.9)

The negative sign indicates that the volume decreases. Bulk stress is defined as the increase in force per unit area.

$\therefore$  Bulk Stress =  $\frac{\text{Increase in force}}{\text{Area}} = \frac{\Delta F}{A}$  ..... (12.10)

Then Bulk Modulus of elasticity  $K$  is defined as

$$K = \frac{\text{Bulk Stress}}{\text{Bulk Strain}}$$

$$= \Delta P \div \frac{-\Delta V}{V}$$

$$K = \frac{-\Delta VP}{\Delta V}$$
 ..... (12.11)

The limit of  $\frac{\Delta P}{\Delta V}$  as  $\Delta P$  and  $\Delta V$  tend to zero is  $\frac{dP}{dV}$

Limit  $\frac{\Delta P}{\Delta V} = \frac{dP}{dV}$   
 $\Delta P, \Delta V \rightarrow 0$

$\therefore k = \frac{-VdP}{dV}$  ..... (12.12)

The reciprocal of bulk modulus of elasticity  $K$  is  $\frac{dP}{dV}$  which is known as compressibility of the material.

$\therefore \frac{1}{K} = \frac{1}{V} \frac{dV}{dP}$  ..... (12.13)

**3.2.1 Bulk Modulus of a Gas – Isothermal Bulk Modulus**

When the pressure and the volume of gas changes at constant temperature, we have the expression



$$PV = \text{Constant} \dots\dots\dots (12.14)$$

It is also known as Boyle’s Law. In addition, it is also associated with what we describe as an isothermal condition. On differentiating this expression with respect to volume V. we get

$$P \frac{dV}{dV} + V \frac{dP}{dV} = 0 \dots\dots\dots (12.5)$$

$$\therefore P + V \frac{dP}{dV} = 0$$

$$\therefore P = -V \frac{dP}{dV} = K \dots\dots\dots (12.6)$$

What does this expression remind you of? You will recall that the bulk modulus of elasticity is given as

$$K = -V \frac{dP}{dV}$$

$$\therefore P = -V \frac{dP}{dV} = k \dots\dots\dots (12.17)$$

Thus the isothermal bulk modulus of elasticity is equal to the pressure P.

**3.2.2 Bulk Modulus of a Gas – Adiabatic Modulus**

By adiabatic, we mean a system whereby heat is not allowed to escape into it or get out of it. The pressure, and volume of a gas can be related in such a way that

$$PV^{3/4} = \text{Constant} \dots\dots\dots (12.18)$$

where  $\gamma = \frac{C_p}{C_v}$

The symbol r is pronounced as gamma.

$\frac{C_p}{C_v}$  is a ratio of the molar heat capacities of a gas at constant pressure  $C_p$  and constant volume  $C_v$ . A state is described as adiabatic when no heat is allowed to leave the system or enter the system of a gas. The external work done is wholly at the expense of the internal energy of the gas. The consequence is that the gas cools down starting from  $PV^\gamma = \text{Constant}$

On differentiating the Eq. (12.18) with respect to V, we get

$$\therefore P \frac{d(V^\gamma)}{dV} + V^\gamma \frac{d(P)}{dV} = 0 \dots\dots\dots (12.19)$$

$$\therefore P \times \gamma V^{\gamma-1} + V^\gamma \frac{dP}{dV} = 0$$

$$\therefore P\gamma = - \frac{V^\gamma}{V^{\gamma-1}} \frac{dP}{dV}$$

On arranging the terms, we get

$$= - \frac{V^\gamma V}{V^\gamma} \frac{dP}{dV}$$

Note that  $V^{\gamma-1} = V^\gamma V^{-1} = \frac{V^\gamma}{V}$

$$\therefore P\gamma = -V \frac{dP}{dV}$$

But  $K = -V \frac{dP}{dV}$

$$\therefore P\gamma = K \dots\dots\dots (12.20)$$

Hence the adiabatic Bulk Modulus is

$$K = P\gamma$$

The following are the values of K at isothermal and adiabatic conditions:

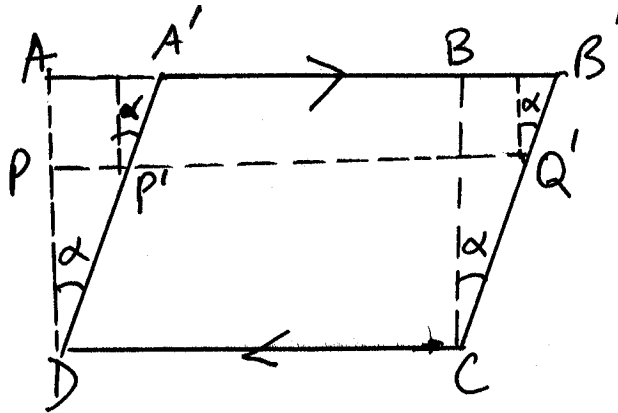
For air at normal pressure,

$$\begin{aligned} K &= 1.0 \times 10^5 \text{Nm}^{-2} \text{ for isothermal bulk modulus, while} \\ K &= 1.4 \times 10^5 \text{Nm}^{-2} \text{ for adiabatic bulk modulus.} \end{aligned}$$

These values are of the order of  $10^5$  times smaller than liquids as gases are much more compressible.

### 3.3 Shear Modulus of Elasticity or Modulus of Rigidity

Consider a block ABCD such as block of rubber as shown in fig. 12.3



**Fig. 12.3: Shear Stress and Shear Strain**

The lower plane is kept fixed. A force  $F$  is applied to the upper side  $AB$  parallel to  $CD$ . The effect of this force on the material is a change in shape from  $ABCD$  to  $A'B'CD$ . There is a displacement of the planes in the body relative to the planes. The angular displacement  $\alpha$  is defined as the shear strain.  $\alpha$  is thus the angular displacement between any two planes of the material. For example planes  $A'B'$  and  $CD$  or planes  $CD$  and  $P'Q'$ .

You should note that in shear modulus, no volume change occurs as in the Bulk modulus of elasticity. Since the force along  $CD$  is  $F$  in magnitude, it forms a couple with the force applied to the upper side  $AB$ .

The shear stress is defined as the shear force per unit area on the face  $AB$  or  $CD$ . The shear has a turning or displacement effect owing to the couple that exists. Besides, the solid does not collapse because in a strained equilibrium position such as  $A'B'CD$ , the external couple is acting on the solid due to the force  $F$  is balanced by an opposing couple due to stresses inside the material. If the elastic limit is not exceeded when a shear stress is applied, its original shape when the stress is removed, the modulus of rigidity or shear modulus  $G$  is defined as

$$G = \frac{\text{Shear Stress}}{\text{Shear Strain}}$$

$$G = \frac{\text{Force per unit area}}{\text{Angular displacement } \alpha}$$

Shear modulus is applicable to the helical spring. When the helical spring is stretched all parts become twisted. The applied force has thus developed a tensional or shear strain. The extension of the spring depends on its shear modulus in addition to its dimension. In sensitive, current measuring instruments, a weak control is needed for the rotation of the instrument coil. A long elastic wire of phosphor – bronze is used instead of a spring.

#### 4.0 CONCLUSION

The ratio of stress and strain defines for us the modulus of elasticity. There are three moduli of elasticity:

- Young modulus
- Bulk modulus
- Shear modulus

When material expands or contracts an enormous force is involved. Besides, energy or work done in stretching or contracting an elastic material. Bulk modulus of elasticity may be considered under two conditions.

- Isothermal condition i.e. at constant temperature
- Adiabatic condition when there is no exchange of heat energy between the gas and its environment

#### 5.0 SUMMARY

In this unit you have learnt that:

- A material is said to be elastic if it is capable of regaining its original shape when the applied force is removed.
- The deformation can be in form of change in length, volume (bulk) or shape.
- The stress on an elastic material is defined as the force per unit  $\frac{F}{A}$ . The unit of which is  $\text{Nm}^{-2}$ .

The strain of a given wire is defined as the ratio between the extension (e) and the original length ( $\ell$ ) of the wire i.e.  $\frac{(e)}{\ell}$

- Young Modulus (E) of elasticity is defined as

$$E = \frac{\text{Tensile Stress}}{\text{Tensile Strain}}$$

$$= \frac{\text{Force per unit area}}{\text{extension / original length}}$$

- The force involved in the contraction or expansion of a wire is given as

$$F = EA \alpha \Delta\theta \quad \text{where}$$

$E$  = Young Modulus  
 $A$  = cross-sectional area  
 $\alpha$  = linear expansivity  
 $\Delta\theta$  = change in temperature

- The energy stored in a wire ( $W$ ) is defined as

$$W = \frac{1}{2} \frac{EAe^2}{\ell}$$

$E$  = Young Modulus  
 $A$  = cross-sectional area  
 $e$  = extension  
 $\ell$  = original length

- Bulk modulus of elasticity ( $K$ ) is defined as

$$K = \frac{\text{Bulk Stress}}{\text{Bulk Strain}}$$

$$= -V \frac{dP}{dV}$$

Where  $V$  is the original volume and  $\frac{dP}{dV}$  is differential rate of change of pressure with respect to volume.

- The compressibility of a material is the reciprocal of the Bulk modulus.

$$\text{Compressibility} = \frac{1}{K} = -V \frac{dP}{dV}$$

- Under isothermal condition, the bulk modulus of a gas is its pressure  $P$ .
- Under adiabatic condition, the bulk modulus of a gas is  $\gamma P$  where

$$\gamma = \frac{C_p}{C_v}$$

the ratio of the molar thermal capacity of the gas at constant pressure  $C_p$  and the molar thermal capacity of the gas at constant volume  $C_v$ , and  $P$  the pressure.

- The shear modulus or the modulus of rigidity ( $G$ ) is defined as

$$G = \frac{\text{Shear Stress}}{\text{Shear Strain}}$$

$$G = \frac{\text{Force per unit area}}{\text{Angular displacement } \alpha}$$

### ANSWER TO SELF ASSESSMENT EXERCISE 1

$$\begin{aligned}
 \text{(i) Tensile stress} &= \frac{\text{Force}}{\text{Area}} \\
 &= \frac{mg}{\frac{\pi D^2}{4}} \\
 &= \frac{2\text{kg} \times 9.8 \frac{\text{m}}{\text{s}^2}}{\frac{\pi \left(\frac{0.64}{1000}\right)^2}{4}} \text{ m}^2 \\
 &= \frac{4 \times 2 \times 9.8\text{N}}{1.287 \times 10^{-6} \text{ m}^2} \\
 &= 6.09 \times 10^7 \text{ N/m}^2
 \end{aligned}$$

$$\begin{aligned}
 \text{(ii) Tensile Stress} &= \frac{e}{L} \\
 &= \frac{\left(\frac{0.60}{1000}\right)\text{m}}{2\text{m}} \\
 &= \frac{0.6}{2} \times 10^{-4} \\
 &= 3 \times 10^{-4}
 \end{aligned}$$

**ANSWER TO SELF ASSESSMENT EXERCISE 2**

$$\begin{aligned}
 \text{Cross-sectional Area of rod} &= 2\text{cm}^2 \\
 &= 2 \times 10^{-4}\text{m}^2 \\
 \text{Change in temperature } \Delta\theta &= (100 - 10)^\circ\text{C} \\
 &= 90^\circ\text{C}
 \end{aligned}$$

$$\text{From } F = EA \alpha \Delta\theta$$

$$\begin{aligned}
 \therefore \text{ Force} &= 2 \times 10^{11}\text{N} \times 2 \times 10^{-4}\text{m}^2 \times 12 \times 10^{-6}\text{C}^{-1} \times 90^\circ\text{C} \\
 &= 2 \times 2 \times 12 \times 90 \times 10^{11} \times 10^{-4} \times 10^{-6} \text{ N} \\
 &= 4321 \times 10^1\text{N} \\
 &= 43.20\text{N} \\
 &= \underline{4.32 \times 10^4\text{N}}
 \end{aligned}$$

**ANSWER TO SELF ASSESSMENT EXERCISE 3**

$$\begin{aligned}
 \text{Energy gained} &= \frac{1}{2} Fe \\
 &= \frac{1}{2} \times 20\text{N} \times (1 \times 10^{-3}\text{m}) \\
 &= 10^{-2}\text{J} \\
 &= 0.01\text{J}
 \end{aligned}$$

$$\begin{aligned}
 \text{Gravitational Energy lost} &= mgh \\
 &= Wh \\
 &= 20\text{N} \times 1 \times 10^{-3}\text{m} \\
 &= 0.02\text{J}
 \end{aligned}$$

The excess energy is dissipated as heat when the weight comes to rest after vibrating at the end of the wire.

**6.0 TUTOR-MARKED ASSIGNMENT**

1. Calculate the maximum load, which may be placed on a steel wire of diameter 1.0mm if the permitted strain must not exceed 1/1000 and the Young modulus for steel is  $2.0 \times 10^{11}\text{N/m}^2$ .
2. An aluminum rod 300cm long, 0.580cm in diameter would normally contract 1.32cm in cooling from  $225^\circ\text{C}$  to  $25^\circ\text{C}$ . Calculate the force which would be required to prevent this contraction? (Young modulus for aluminum =  $7.0 \times 10^{10}\text{N/m}^2$ ).

## 7.0 REFERENCES/FURTHER READING

- Awe, O. and Okunola, O.O. (1986). *Comprehensive Certificate Physics*, Ibadan: University Press.
- Ference, M. (Jnr.), Lemon, H.B. and Stephenson, RJ (1970). *Analytical Experimental Physics*, Chicago: The University of Chicago Press.
- Feynman, R.P., Leighton, R.B. and Sands, M (1971). *The Feynman Lectures on Physics*, California: Addison-Wesley Publishing Company.
- Flowers, B.H. and Mendoza, E (1970). *Properties of Matter*, London: John Wiley and Sons Limited.
- Noaks, M.A. (1963). *New Intermediate Physics*, Canada: Macmillan and company Limited.
- Soars, F.W., Zemansky, M.W. and Young, H.D. (1980). *College Physics*. London: Addison-Wesley Publishing Company.
- Tyler, F. (1966). *Heat and Thermodynamics*. London: Edwards Arnold Publisher Limited.
- Wilkinson, J. (1983). *Essentials of Physics*, Australia: Macmillan Education Publishers.
- Zemansky, M.W. (1968). *Heat and Thermodynamics*. New York: McGraw-Hill Book Company.



## UNIT 3 KINETIC THEORY OF GASES AND ITS APPLICATION

### CONTENTS

- 1.0 Introduction
- 2.0 Objectives
- 3.0 Main Content
  - 3.1 Assumptions of Kinetic Theory for an Ideal Gas
  - 3.2 Pressure Exerted by a Gas
    - 3.2.1 Root Mean Square Velocity (R.M.S) of Gas Molecules
  - 3.3 Deduction of Gas Laws from Kinetic Theory of Gases
  - 3.4 Variation of the Root Mean Square Speed
  - 3.5 Distribution of Molecular Speeds
  - 3.6 Boltzmann Constant
  - 3.7 Internal Energy of a Gas
- 4.0 Conclusion
- 5.0 Summary
- 6.0 Tutor Marked Assignment
- 7.0 References/Further Reading

### 1.0 INTRODUCTION

In the previous unit, you have studied that liquid and gases experience stresses and strains when forces are applied on them. The substances are made up of molecules which exists in free state and possess all the basic properties of the substance. The state (solid, liquid or gas) of a substance is determined by the interplay of thermal energy and intermolecular forces. This gives rise to molecular theory. Later it was supplemented by the laws of mechanics for individual molecules leads to kinetic theory.

In this unit, you will learn to derive an expression for pressure exerted by a gas and deal with kinetic theory of gases and see how it can explain all the gas laws of an ideal gas. You will also learn about the root mean square velocity of the molecules of a gas.

Further more the theory enables us to:

- (i) Determine the root -mean -square velocity (r.m.s.) of the molecules of a given mass of gas.
- (ii) Show variation of the r.m.s speed.
- (iii) Show the distribution of molecular speeds.
- (iv) Derive the internal energy of a gas.

## 2.0 OBJECTIVES

At the end of this module, you should be able to:

- state the assumption of the kinetic theory for an ideal gas
- derive an expression for the pressure of a gas in an enclosed system
- explain and derive the root-mean-square velocity (r.m.s.) of gas molecules
- derive the gas laws from the kinetic theory of gases
- show and explain the variation of r.m.s. speed
- explain Boltzmann constant
- derive the internal energy of a gas.

## 3.0 MAIN CONTENT

### 3.1 Kinetic Theory of Gases and its Applications

In this section, we shall explain the gas laws and other behaviour of gases by considering the motion of their molecules. That is, we will derive the gas laws through the Kinetic theory of gases. To do this, we use the following assumptions about the kinetic theory of gases:

- (i) the gas consists of a very large number of exceedingly small - particles -identifiable with chemical molecules -which are in incessant, rapid, haphazard motion. All direction of motions are equally probable.
- (ii) for a given mass of gas, all these particles are identical and the smallest volume of gas consists of large number of molecules (i.e. in a  $1\text{mm}^3$ , under standard condition of temperature and pressure, there are nearly  $3 \times 10^{16}$  molecules).
- (iii) the average distance between the molecules (called the mean free path) is so large compared with their linear dimensions that the particles may be considered to be of negligible size, i.e. the volume occupied by the molecules is negligible compared with the volume occupied by the entire gas.
- (iv) the molecules exert no appreciable force on each other so that between collisions, they travel in straight paths, i.e. the attractive forces between molecules are negligible - there is no force of attraction among the molecules;
- (v) collisions molecules between and with the walls are perfectly elastic. There is thus no loss of Kinetic energy during a collision

process and a molecule rebounds from the wall with a velocity equal to that with which it strikes it;

- (vi) the duration of a collision is negligible compared with the time between collisions.

We shall now use the above assumptions to derive an expression for the pressure exerted by a given mass of gas enclosed in a cubic container of length  $l$ .

### 3.2 Pressure Exerted By Gas

Consider that there are  $N$  molecules of gas per cubic metre each of mass  $m$  as shown in fig. 13.1.

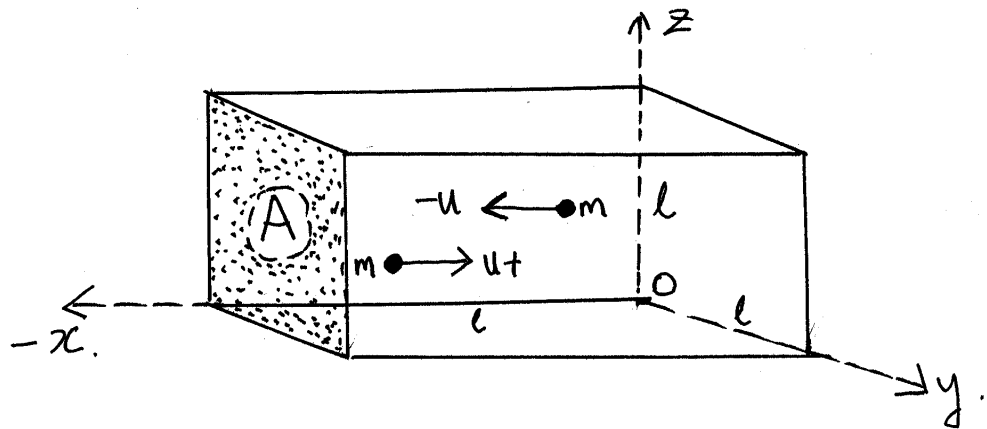


Fig. 13.1

Generally, the molecules move in different directions with different velocities  $C_1, C_2 \dots C_N$ . Let us consider the molecules with particular velocity, say  $C_1$ . This  $C_1$  has velocity components in three directions,  $O_x, O_y, O_z$  parallel to the three edges of the cube passing through the corner  $O$ . Suppose these velocity components are  $u^2, v^2, w^2$  in the directions respectively. Then one can write,

$$C_1^2 = u^2 + v^2 + w^2 \dots \dots \dots (13.1)$$

Since  $u, v, w$ , are at  $90^\circ$  to each other.

Let us now consider a molecule moving in the direction  $O_x$  normal to one face of the cube. The incident velocity  $-u$  and the rebound velocity after collision is  $+u$ . Using the  $O_x$  axis as being negative for a molecule of mass  $m$  and initial velocity  $-u$ , its initial momentum is  $-mu$ . On rebound its final velocity is  $+u$  hence its final momentum is  $+mu$ ]

Time taken by the molecule to travel across to the opposite face and back. If the total distance covered is  $2\ell$  and the molecule has a velocity  $u$ , the time taken =  $\frac{2\ell}{u}$  before it makes another impact again. Hence this

molecule makes  $\frac{u}{2\ell}$  collision per second.

Hence the change in momentum per second

$$\begin{aligned}
 &= \text{number of collisions per second} \times \text{change in momentum} \\
 &= \frac{mu^2}{\ell} = F \dots\dots\dots (13.3)
 \end{aligned}$$

But according to Newton's second law of motion, the change in momentum per second is force. So the magnitude of the force on the face of the cube =  $\frac{mu^2}{\ell} = F \dots\dots\dots (13.4)$

This is the force due to the component  $u$  of velocity  $C_1$ . Adding the similar components of the velocity of all the other molecules, thus the total force on this face is

$$F = \frac{m}{\ell} (u_1^2 + u_2^2 + \dots\dots\dots + u_N^2) \dots\dots\dots (13.5)$$

The square of velocity  $u$  components is the average of all the square values of

$$\begin{aligned}
 &(u_1^2 + u_2^2 + \dots\dots\dots + u_N^2) \\
 \therefore \overline{u^2} &= \frac{u_1^2 + u_2^2 + \dots\dots\dots + u_N^2}{N} \\
 \therefore N\overline{u^2} &= u_1^2 + u_2^2 + \dots\dots\dots + u_N^2 \dots\dots\dots (13.6)
 \end{aligned}$$

Substituting Eq. (13.6) in Eq. (13.5), we get

$$\text{Hence the total magnitude of the force} = \frac{Nm\overline{u^2}}{\ell} = F \dots\dots\dots (13.7)$$

For a large number of molecules in the cube, the mean square of the components along must be equal.

$$\therefore \overline{u^2} = \overline{v^2} + \overline{w^2} \dots\dots\dots (13.8)$$

$$\text{But } \overline{u^2} + \overline{v^2} + \overline{w^2} = \overline{C^2} \dots\dots\dots (13.9)$$

Where  $\overline{C^2}$  is the mean square velocity of all the molecules. When the gas is in equilibrium there will be no preferred direction of motion i.e. all direction of velocity will be equally probable and therefore

$$\therefore \overline{u^2} = \frac{\overline{C^2}}{3} \dots\dots\dots (13.10)$$

$$\therefore F = Nm \frac{\overline{C^2}}{3\ell} \dots\dots\dots (13.11)$$

From the concept of Pressure, P, Pressure is defined as the force per unit area.

$$\begin{aligned} \therefore P &= \frac{\text{Force}}{\text{Area}} \\ P &= \frac{F}{\ell^2} \dots\dots\dots (13.12) \end{aligned}$$

Substituting for F in Eq. (13.11), we get

$$\therefore P = Nm \frac{\overline{C^2}}{3\ell} \dots\dots\dots (13.13)$$

But as you know that  $\ell^3 = V$ , the volume of the cube

$$\begin{aligned} \therefore P &= Nm \frac{\overline{C^2}}{3V} \\ \therefore PV &= \frac{1}{3} Nm \overline{C^2} \dots\dots\dots (13.14) \end{aligned}$$

Since the Nm is the total mass of N molecule which is M and

$$\begin{aligned} \frac{M}{V} &=, \rho \text{ the density of the gas} \\ \therefore P &= Nm \frac{\overline{C^2}}{3V} \\ \therefore P &= \frac{1}{3} \rho \overline{C^2} \dots\dots\dots (13.15) \end{aligned}$$

This is an important result. It relates  $\rho$  with P and C. We have derived this result by assuming a cube.

### 3.2.1 Root Mean Square Velocity (R.M.S) of Gas Molecules

From Eq. (13.15), you know that the expression for pressure can be written as,  $\frac{1}{3}\rho\overline{C^2}$

Therefore the root-mean-square velocity of all the gas molecules can be defined as

$$\begin{aligned} \therefore \overline{C^2} &= \frac{3P}{\rho} \\ \therefore \sqrt{\overline{C^2}} &= \sqrt{\frac{3P}{\rho}} \dots\dots\dots (13.6) \end{aligned}$$

Consequently, if we know the pressure (P) and its density  $\rho$  of the gas. We can calculate the r.m.s. velocity of the gas molecules.

#### SELF ASSESSMENT EXERCISE 1

Given that the pressure of  $1.013 \times 10^5 \text{Pa (Nm}^{-2}\text{)}$  is exerted on a given mass of hydrogen gas which has density  $0.09\text{kgm}^{-3}$  at a temperature of  $0^\circ\text{C}$ . Calculate its r.m.s. velocity.

### 3.3 Deduction of Gas Laws from Kinetic Theory of Gases

Now in the subsequent section, we will discuss about the gas laws which were derived using the Eq. (13.15).

It has been shown earlier that for N molecules, each mass m, the mass M of a gas is Nm.

$$PV = \frac{1}{3}Nm\overline{C^2} \dots\dots\dots (13.17)$$

By multiplying and dividing by 2 of the R.H.S of Eq. 13.17

$$PV = \frac{2}{3}\left(\frac{1}{2}M\overline{C^2}\right) \dots\dots\dots (13.18)$$

But  $\frac{1}{2}M\overline{C^2}$  in Eq. (13.18) is the average Kinetic energy of translation of the gas molecules.

(Rotational energy of the gas molecules is neglected). Now, heat is a form of energy and it is reasonable to assume that the gas molecules have greater energy of movement when its temperature is higher. We

can therefore make the assumption that  $\frac{1}{2}M\overline{C^2}$  is proportional to its absolute temperature T.

Hence,  $\frac{1}{2}M\overline{C^2} \propto T$

$\therefore \frac{1}{2}M\overline{C^2} = KT \dots\dots\dots (13.19)$

Where, K is a constant of proportionality.

Now putting Eq. (13.18) in Eq. (13.19) as given below,

$$PV = \frac{2}{3} \left( \frac{1}{2}M\overline{C^2} \right)$$

We get,

$\therefore PV = \frac{2}{3} KT \dots\dots\dots (13.20)$

$\therefore PV = \text{Constant} \times T$   
 $PV = RT \dots\dots\dots (13.21)$

Where R is the constant for 1 mole of gas  
 Furthermore, we can also say that

$$PV = \frac{1}{3}M\overline{C^2} = RT \dots\dots\dots (13.22)$$

On dividing by 1/2 both sides, we get

$\therefore \frac{1}{2}M\overline{C^2} = \frac{3}{2} RT$

But,  $\frac{1}{2}M\overline{C^2} = \text{K.E. of the gas molecules}$

$\therefore \text{K.E.} = \frac{3}{2} RT \dots\dots\dots (13.23)$

From,  $PV = RT$   
 at constant temperature

$\therefore PV = \text{Constant}$

This is Boyle's law

$$\frac{PV}{T} = R \quad (\text{The general gas law}) \dots\dots\dots (13.24)$$

### 3.4 Variation of the Root Mean Square Speed

Consider the Eq. (13.22),

$$PV = \frac{1}{3}M\overline{C^2} = RT$$

$$\text{Then } \frac{1}{3}M\overline{C^2} = RT$$

On rearranging the terms, we get

$$\therefore \overline{C^2} = \frac{3RT}{M}$$

$$\therefore \sqrt{\overline{C^2}} = \sqrt{\frac{3RT}{M}} \dots\dots\dots (13.25)$$

Since R is a constant, hence for a given temperature T, it can be concluded that r.m.s. velocity is inversely proportional to the molar mass (M) of the gas.

$$\text{r.m.s. velocity} \propto \frac{1}{\sqrt{M}}$$

This relationship can be used to compare the r.m.s. velocities of two gases such as oxygen and hydrogen.

$$\frac{\text{r.m.s. velocity of oxygen}}{\text{r.m.s. velocity of hydrogen}} = \sqrt{\frac{MH_2}{MO_2}}$$

Where,  $MH_2 =$  molar mass of hydrogen = 2 and,  
 $MO_2 =$  molar mass of oxygen = 32

$$\text{However from, } \sqrt{\overline{C^2}} = \sqrt{\frac{3RT}{M}}$$

For a given mass of gas at different temperatures

$$\text{r.m.s. velocity } \sqrt{\overline{C^2}} \propto \sqrt{T}$$

i.e. the root-mean-square velocity is directly proportional to the square root of its absolute temperature.



**SELF ASSESSMENT EXERCISE 2**

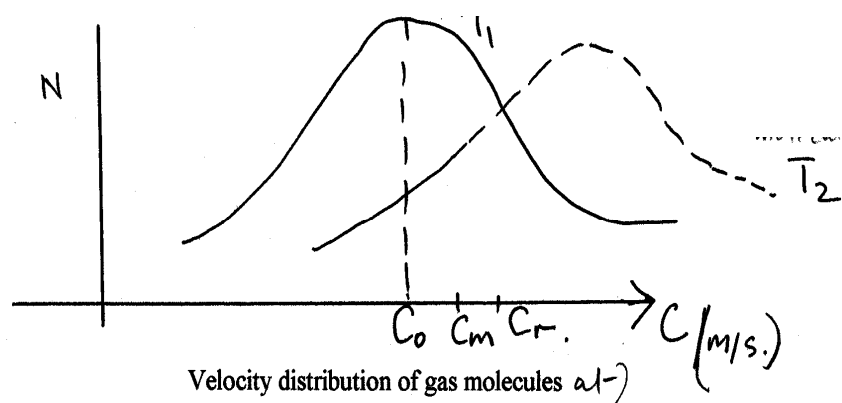
The r.m.s. velocity of hydrogen is  $1800\text{ms}^{-1}$  at a given temperature, calculate the r.m.s. velocity of oxygen at the same temperature. (Molar mass of hydrogen = 2, molar mass of oxygen = 32).

**SELF ASSESSMENT EXERCISE 3**

The r.m.s. velocity of oxygen molecules is  $400\text{ms}^{-1}$  at  $0^\circ\text{C}$ . Calculate its r.m.s. velocity at  $100^\circ\text{C}$ .

**3.5 Distribution of Molecular Speeds**

In this section we are concerned about how the speeds of the molecules are distributed in a given closed system at a particular temperature. You will recall the assumption that not all molecules move with the same speed. So now you may ask: what is the distribution of molecules speed? So far, we have discussed what is meant by the root-mean-square speed and the mean speed of molecules in a given gas. The actual speeds vary from low to high values. At a given temperature, the variation follows what is known as Maxwellian distribution as shown in fig. 13.2.



The vertical axis represents the number  $N$  of molecules which have speeds within a given range about a particular value  $C$ . The probable speed  $C_0$  is the maximum value. The mean speed  $C_m$  in the graph is greater than the probable speed  $C_0$  by about 13%. While the root-mean-square  $C_r$  is greater than the probable speed  $C_0$  by about 23%. These variations are shown with the curve  $T_1$ . At higher temperatures as shown in the fig. 13.2, by the curve  $T_2$ , the speed of the molecules increases. You will note that as the temperature increases, the curve becomes broader and flattened.

As you will recall that in diffusion we learnt about the average speed  $\bar{C}$  of the individual molecules. The greater the value of  $\bar{C}$ , the faster the

rate of diffusion. However, when it comes to the pressure of a gas, its value is associated with the mean square  $\overline{C^2}$ .

### 3.6 Boltzmann Constant

It will be recalled that when we derived the expression for pressure for a given mass of gas, we obtained the expression

$$PV = \frac{1}{3} \frac{N}{V} m \overline{C^2}$$

$$\text{Or } PV = \frac{1}{3} N m \overline{C^2}$$

$$PV = \frac{1}{3} \left( \frac{1}{2} m \overline{C^2} \right)$$

Where  $\frac{1}{2} m \overline{C^2}$  is the average Kinetic energy of the gas.

For one mole of a monatomic gas, translational K.E. can be related with its temperature such that

$$\frac{1}{2} m \overline{C^2} = \frac{3}{2} RT$$

If the number of molecules in one mole of a gas is  $N_A$ , the Avogadro constant which is  $6.02 \times 10^{23} \text{ mole}^{-1}$

$$\text{The average K.E. per mole} = \frac{3}{2} \frac{RT}{N_A} = \frac{3}{2} RT \dots\dots\dots (13.26)$$

Where  $K$  is the Boltzmann constant, thus  $K = \frac{R}{N_A}$ , where  $R = 8.3 \text{ JK}^{-1} \text{ mol}^{-1}$

$$\therefore K = \frac{R}{N_A} = 1.38 \times 10^{-23} \text{ JK}^{-1}$$

The value of Boltzmann Constant is  $1.38 \times 10^{-23} \text{ JK}^{-1}$ .

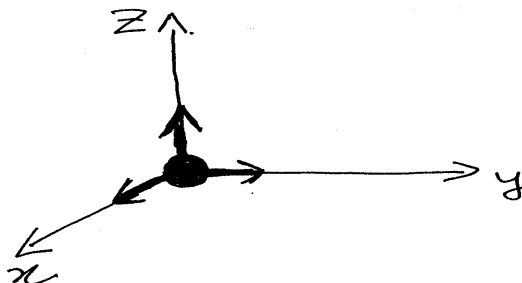
### 3.7 Internal Energy of a Gas

In this section we shall consider two types of gas

- (i) monatomic gas
- (ii) diatomic gas

No we will discuss the internal energy and the degree of freedom possessed by each type of gas.

### Monatomic Molecule



**Fig. 13.3: Degree of Freedom of a Gas Molecule**

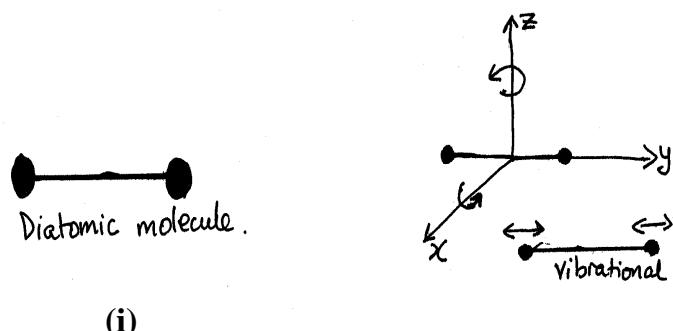
Consider a monatomic molecule of a gas (like helium, argon and krypton) at the point o in fig. 13.3. It is capable of moving in  $O_x$ ,  $O_y$  and  $O_z$  directions. We therefore say that it has three translational degrees of freedom. As you know that the total translational Kinetic energy of a molecule is  $\frac{3}{2}KT$ , since all the three directions are equivalent. Hence the K.E. per degree of freedom of a molecule

$$= \frac{3}{2}KT \div 3 \text{ degrees} = \frac{1}{2}KT.$$

Therefore, the translational Kinetic energy associated with each component of velocity is just one third of the total translational kinetic energy.

### Monatomic Molecule

A diatomic molecule consists of two atoms with a bond between them Fig. 13.4(i).



Like a dumbbell, it moves through the air with the following degrees of freedom:

- (i) three translational degrees of freedom x, y and z
- (ii) two rotational degrees of freedom. Since it rotates about two axes at right angles to the line joining them (x & z).
- (iii) the vibrational energy is also there but negligible compared with others.

That is for a diatomic molecule there are five degrees of freedom.

Hence the total energy of the diatomic molecule =  $5 \times \frac{1}{2} kT = \frac{5}{2} kT$

Therefore, the molar heat capacity for 1 mole of the gas:

$$C_v = \frac{5}{2} R \dots\dots\dots (13.27)$$

$$\therefore C_p = C_v + R = \frac{5}{2} R + R = \frac{7}{2} R \dots\dots\dots (13.28)$$

Therefore for monatomic molecule, the internal energy U is only translational K.E.

The molar heat capacity at constant volume  $C_v$  is the heat energy required to raise the temperature of 1 mole of gas by 1K. This is also the rise in internal energy of an ideal gas when its temperature rises by 1K.

$$\therefore C_v = \Delta U = \frac{3}{2} R (T + 1) - \frac{3}{2} RT = \frac{3}{2} R$$

$$\Delta U = C_v = \frac{3}{2} R$$

The molar heat capacity at constant pressure  $C_p$  is given by

$$C_p - C_v = R$$

$$\therefore C_p - C_v = R$$

$$\Delta U = C_p = \frac{5}{2} R$$

Therefore, the ratio of molar heat capacities is given as for monatomic molecules

$$\frac{C_p}{C_v} = \gamma = \frac{5}{3} = 1.67 \dots \dots \dots (13.29)$$

For diatomic molecule, the ratio of heat capacities can be obtained as:

$$\Delta U = C_v = \frac{5}{2} R$$

$$\Delta U = C_p = C_v + R = \frac{7}{2} R$$

$$\Delta U = C_p = \frac{7}{2} R$$

$$\frac{C_p}{C_v} = \gamma = \frac{7}{5} = 1.40 \dots \dots \dots (13.30)$$

Here  $\gamma$  is called (gamma), which is the ratio of heat capacities. This shows that the ratio of heat capacities decreases with increasing atomicity of gases.

#### 4.0 CONCLUSION

Some assumptions have been given to the Kinetic theory of an ideal gas. By using these assumptions the expression for the pressure on a gas has been derived which is in consonance with Boyle's law ( $PV = K$ ) and the equation of state ( $PV = nRT$ ). The root-mean-square (r.m.s.) velocity of a gas molecules have been explained and derived. Finally, the internal energy of a gas has been derived.

#### 5.0 SUMMARY

In this unit you have learnt:

- About the basic assumptions of the Kinetic Theory of gases;
- How these assumptions were used to derive the expression for the pressure exerted by a given mass of gas in a closed system.

$$PV = \frac{1}{3} \frac{N}{V} m \overline{C^2} \text{ or}$$

$$PV = \frac{1}{3} \frac{N}{V} m \overline{C^2} = RT$$

The kinetic energy of translation was given as  $PV =$

$$\frac{1}{2} m \overline{C^2} = \frac{3}{2} RT$$

- That the ideal gas law  $PV = RT$  only follows from Kinetic Theory of gases by assuming that the kinetic energy of translation is proportional to the absolute temperature  $T$ ;

- The root-mean-square velocity of the gas  $\sqrt{C^2} = \sqrt{\frac{3P}{\rho}}$  where P is the pressure of the gas and  $\rho$  is the density of the gas;
- The root-mean-square velocity of the gas is independent of the pressure, directly proportional to  $\sqrt{T}$  (the absolute temperature) and inversely proportional to  $\sqrt{M}$  where M is the mass of one mole of the gas;  
For a monatomic gas, the molar heat capacity at constant volume  $C_v = \frac{3}{2}R$ ; the molar heat capacity at constant pressure  $C_p = \frac{5}{2}R$ ;  
the ratio  $\frac{C_p}{C_v} = \gamma$  is just equal to 1.67; and
- For a diatomic gas,  $C_v = \frac{5}{2}R$ ,  $C_p = \frac{7}{2}R$  and  $\frac{C_p}{C_v} = \gamma$  is just equal to 1.40.

### ANSWER TO SELF ASSESSMENT EXERCISE 1

From  $\sqrt{C^2} = \sqrt{\frac{3P}{\rho}}$

$$\begin{aligned} \therefore \text{r.m.s. velocity} &= \sqrt{C^2} = \sqrt{\frac{3 \times 1.013 \times 10^5}{0.09}} \\ &= 1840 \frac{\text{m}}{\text{s}} \\ &= 1.84 \text{kms}^{-1} \\ \text{r.m.s. velocity} &= 1.84 \text{kms}^{-1} \end{aligned}$$

### ANSWER TO SELF ASSESSMENT EXERCISE 2

Using the relation (13.25), we can write

$$\frac{\sqrt{C^2_{O_2}}}{\sqrt{C^2_{H_2}}} = \frac{\sqrt{MH_2}}{\sqrt{MO_2}}$$

Substituting the values,

$$\therefore \frac{\sqrt{C^2_{O_2}}}{1800 \frac{\text{m}}{\text{s}}} = \frac{\sqrt{2}}{\sqrt{32}} = \frac{1}{4}$$

We get

$$\therefore \sqrt{C^2 O_2} = 1800 \frac{\text{m}}{\text{s}} \times \frac{1}{4} = 450 \frac{\text{m}}{\text{s}}$$

Hence, the r.m.s. velocity of oxygen is  $450\text{ms}^{-1}$

### ANSWER TO SELF ASSESSMENT EXERCISE 3

We know that

$$\sqrt{C^2} \propto \sqrt{T}$$

Therefore,

$$\frac{\sqrt{C^2 T_1}}{\sqrt{C^2 T_2}} = \frac{\sqrt{T_1}}{\sqrt{T_2}}$$

Substituting the value in this equation:

$$\frac{\sqrt{C^2 0^\circ \text{C}}}{\sqrt{C^2 100^\circ \text{C}}} = \frac{\sqrt{273\text{K}}}{\sqrt{273 + 100\text{K}}}$$

$$\therefore \frac{400\text{ms}^{-1}}{\sqrt{C^2 100^\circ \text{C}}} = \sqrt{\frac{273}{373}}$$

We get,

$$\therefore \sqrt{C^2 100^\circ \text{C}} = 400 \frac{\text{m}}{\text{s}} \times \sqrt{\frac{373}{273}} = 468\text{ms}^{-1}$$

Thus the r.m.s. velocity of oxygen molecules at  $100^\circ\text{C}$  is  $468\text{ms}^{-1}$ .

## 6.0 TUTOR MARKED ASSIGNMENT

- Assuming air has 2% oxygen molecules and 80% nitrogen molecules of relative molar masses 32 and 28 respectively. Calculate
  - the ratio of the r.m.s velocity of oxygen to that of nitrogen; and
  - the ratio of the partial pressure of oxygen to that of nitrogen in air.
- In a vessel, hydrogen gas contains  $1.0 \times 10^{24}$  molecules per  $\text{m}^3$  which have a root-mean-square velocity of  $180\text{ms}^{-1}$ . Calculate

the pressure of gas assuming that the Avogadro constant =  $6 \times 10^{23} \text{ mole}^{-1}$  and the relative molar mass of hydrogen is 2.

3. Given that r.m.s. velocity of hydrogen is  $1800 \text{ms}^{-1}$  at a given temperature. Calculate the r.m.s. of nitrogen at the same temperature.
4. The r.m.s. velocity of oxygen molecules is  $400 \text{ms}^{-1}$  at  $0^\circ\text{C}$ . Determine its r.m.s. velocity at  $150^\circ\text{C}$ .

## 7.0 REFERENCES/FURTHER READING

Awe, O. and Okunola, O.O. (1986). *Comprehensive Certificate Physics*, Ibadan: University Press.

Ference, M. (Jnr.), Lemon, H.B. and Stephenson, RJ (1970). *Analytical Experimental Physics*, Chicago: The University of Chicago Press.

Feynman, R.P., Leighton, R.B. and Sands, M (1971). *The Feynman Lectures on Physics*, California: Addison-Wesley Publishing Company.

Flowers, B.H. and Mendoza, E (1970). *Properties of Matter*, London: John Wiley and Sons Limited.

Noaks, M.A. (1963). *New Intermediate Physics*, Canada: Macmillan and company Limited.

Soars, F.W., Zemansky, M.W. and Young, H.D. (1980). *College Physics*. London: Addison-Wesley Publishing Company.

Tyler, F. (1966). *Heat and Thermodynamics*. London: Edwards Arnold Publisher Limited.

Wilkinson, J. (1983). *Essentials of Physics*, Australia: Macmillan Education Publishers.

Zemansky, M.W. (1968). *Heat and Thermodynamics*. New York: McGraw-Hill Book Company.



## UNIT 4 DENSITY

### CONTENTS

- 1.0 Introduction
- 2.0 Objectives
- 3.0 Main Content
  - 3.1 Concept of Density
    - 3.1.1 Mass of a Body
    - 3.1.2 Volume of a Body
    - 3.1.3 Volume of Regular Objects
    - 3.1.4 Volume of Irregular Objects
  - 3.2 Determination of the Density of an Object
  - 3.3 Density of Mixtures
- 4.0 Conclusion
- 5.0 Summary
- 6.0 Tutor-Marked Assignment
- 7.0 References/Further Reading

### 1.0 INTRODUCTION

Matter is a substance which has certain mass and occupies some volume. But you must have observed that some substances are denser than others. It means that the individual particles of a substance are more closely packed together.

*Suppose you are asked this question: “Which is heavier, one kilogram of copper or one kilogram of feathers?” What would be your answer?*

This question has elicited many answers from students. Some students would say the feathers are heavier. But what is your answer? Think very well before giving your own solution.

However, the obvious answer is “Neither is heavier.” The two objects are the same mass of one kilogram. But on a second thought, about these objects, something seems to make a difference. And what is that difference?

The difference is in terms of the space (volume) occupied by both objects. Besides, when the metal copper is placed in water it sinks while the feathers will float. The idea that relates the mass with volume and whether an object will sink or not is known as density. **Therefore, density is a physical property of matter that describes the degree of compactness of a substance.**

Thus in this unit we shall deal with the concept of density and its measurement.

## 2.0 OBJECTIVES

At the end of his unit you should be able:

- explain the meaning of density
- define the concept of density
- describe an experiment on how to determine the density of:
  - (i) A regular shaped object
  - (ii) An irregular shaped solid
  - (iii) A liquid, by method of displacement
- explain the meaning of relative density
- solve problems on density.

## 3.0 MAIN CONTENT

### 3.1 Concept of Density

The density of an object refers to how heavy or light that object is relative to water or air.

Density is defined as **“The mass of the body per unit volume.”**

Density =  $\frac{\text{Mass}}{\text{Volume}}$  That is, the density of a body is the mass of that body in kilograms per one meter cube of its volume.

Thus in order to determine the density of a body, the following factors must be known: its mass and its volume.

*What then is the mass of a body? What is the volume of the body?*

The answers to these two questions enable us to define the density of the body.

#### 3.1.1 Mass of a Body

The quantity of matter in a body defines its mass. It is the degree of inertia i.e. its reluctance to motion. It is measured in kilogram (kg) using the S.I. unit system. Sometimes we use the smaller units such as (g) or milligram (mg). *The question you may ask now: How do we measure the mass of an object?*

The beam balance or the scale may be used to measure the mass of a body. The mass of a body is compare with the standard mass of one

kilogram of Platinum-Iridium in Paris. Thus by the definition of density, we need to determine the mass of the object using the beam balance. Having done this, we then determine its volume.

### 3.1.2 Volume of a Body

The volume of a body is the amount of space it occupies – its capacity. It is measured in cubic ( $\text{m}^3$ ) or cubic centimeter ( $\text{cm}^3$ ).

Observe these various conversions

$$\text{If} \quad 1\text{cm} = \frac{1}{100}\text{m}$$

$$\begin{aligned} \therefore \quad 1\text{cm}^3 &= \frac{1}{100}\text{m} \times \frac{1}{100}\text{m} \times \frac{1}{100}\text{m} \\ &= \frac{1}{10^6}\text{m}^3 \end{aligned}$$

$$\therefore \quad 1\text{cm}^3 = 1 \times 10^{-6}\text{m}^3$$

$$\text{or} \quad 1\text{m}^3 = 1 \times 10^6\text{cm}^3$$

The one cubic centimeter ( $\text{cm}^3$ ) is also equal to one milliliter.  $1\text{cm}^3 = 1\text{ml}$ .

The problem now is “**How is volume of a body determined?**” From experience you will realize that this can be done in two ways:

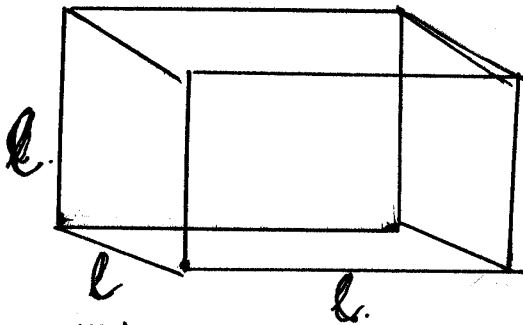
- The use of regular method for regular objects
- The use of displacement method for irregular objects.

Now in the next section, we will discuss about the methods of determination of volume of regular objects.

### 3.1.3 Volume of Regular Objects

Regular objects include things like a cube, a cuboid, a cylinder, a sphere, and a cone. Their shapes are very distinct and unique. Their volume can then be determined with the knowledge of their dimensions such as length, breadth, height, radius or diameter.

**A Cube**

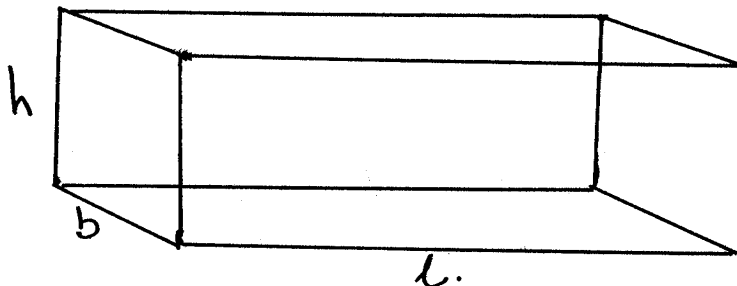


**Fig. 14.1: A Cube**

The length, breadth and height of a cube are of the same length  $l$ . Therefore, by definition, the volume of a cube.

$$V = l \times l \times l = l^3 \dots\dots\dots (14.1)$$

**A Cuboid**

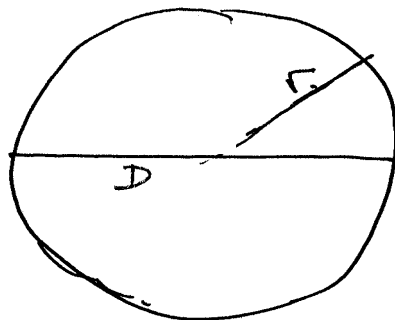


**Fig. 14.2: A Cuboid**

A cuboid has a height ( $h$ ), a breadth ( $b$ ) and a length ( $l$ ). Hence by definition the volume of cuboid is

$$V = h \times b \times l \dots\dots\dots (14.2)$$

**A Sphere**



**Fig. 14.3: A Sphere**

A sphere is like a ball with a constant radius  $r$  or diameter  $D$ . BY definition, the volume of a sphere is given by

$$V = \frac{4}{3} \pi r^3 \dots\dots\dots (14.3)$$

Where, the diameter is given as  $D$ , and where  $D = 2r$

$$\therefore r = \frac{D}{2}$$

Hence, in terms of the diameter  $D$  the volume of the sphere can be expressed as

$$V = \frac{4}{3} \pi \left(\frac{D}{2}\right)^3$$

$$V = \frac{4}{3} \pi \frac{D^3}{8} \dots\dots\dots (14.4)$$

**Cylinder**



**Fig. 14.4: A Cylinder**

A cylinder is like a drum or tin of milk with a height  $h$  and circular cross-section of radius  $r$  (See fig. 14.4).

By definition, the volume of a cylinder is given as

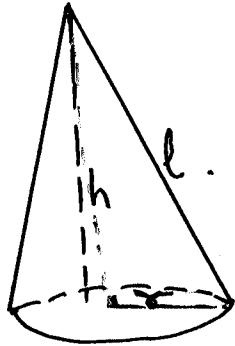
$$V = \pi r^2 h \dots\dots\dots (14.5)$$

This relation can also be expressed in terms of Diameter  $D$  as

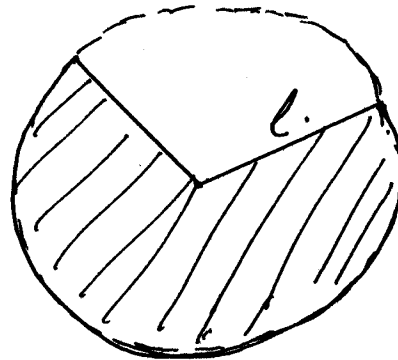
$$= \pi \left(\frac{D}{2}\right)^2 h$$

$$V = \pi \frac{D^2}{4} h \dots\dots\dots (14.6)$$

**A Cone**



**Fig. 14.5(i): A Cone**

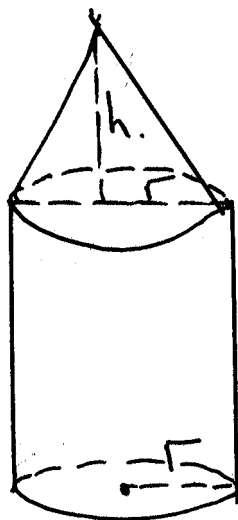


**Fig. 14.5(ii): A Sector**

A cone is like a toy top with a circular surface, which tapers to a vertex (fig. 14.5(i)). It is usually made from a sector of a circular sheet. The vertical height of the cone is  $h$  with the circular base having a radius  $r$ . By definition the volume of a cone is given as

$$V = \frac{4}{3} \pi r^2 h \dots\dots\dots (14.7)$$

Note that any object may be in form of a combination of the above objects. For example, we can have a combination of a cone and a cylinder as shown in fig. 14.6.



**Fig. 14.6**

Once you can identify the shape of the regular object, you can then determine its volume using the appropriate formula. But,

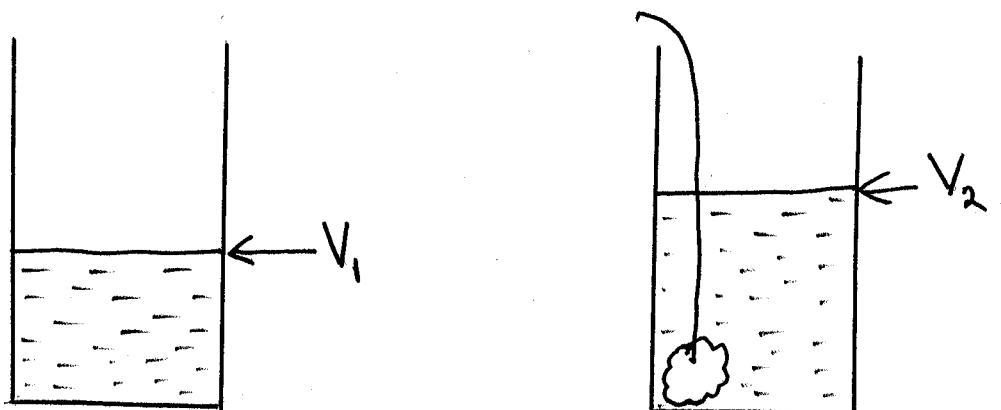
**How do we determine the volume of an irregular object like you? Can you use your height, breadth and length?** No. We shall find out how to determine the volume of an irregular object in the next section.

### 3.1.4 Volume of Irregular Objects

Irregular objects, in this case, are those objects that do not have regular shapes. These objects include stoned or any solid object that does not conform with any of the regular objects. We use indirect method of determining their volumes. The method is described as the displacement method.

#### Method 1

In this method, we use a measuring cylinder as shown in fig. 14.7 (i) & (ii).



**Fig. 14.7**

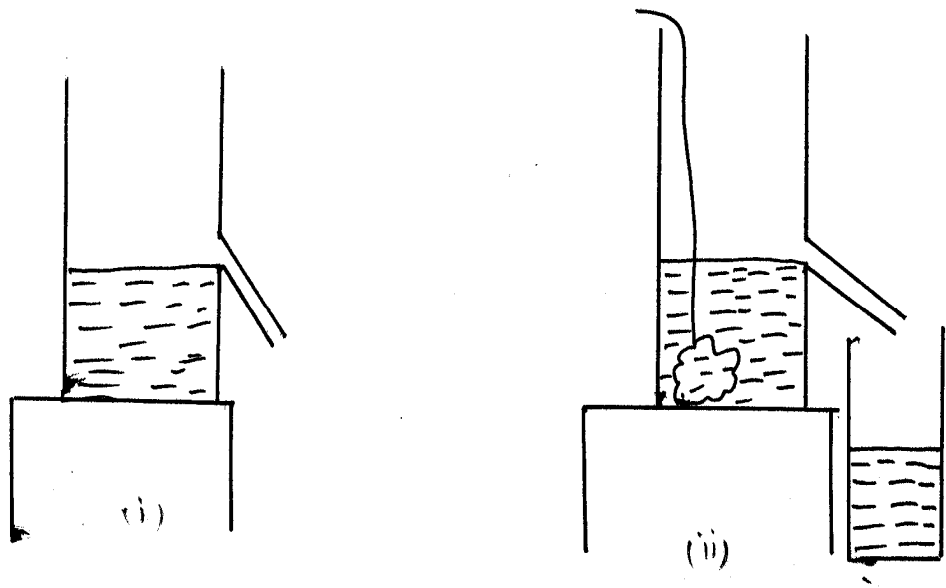
First, you will pour some water into the cylinder and then observe the initial level of the water inside the cylinder ( $V_1$ ) as shown in fig. 14.7.

Then, you tie a string on the stone, the irregular object and carefully lower the stone into the water with the aid of the string making sure there is no splash. But it is to be assumed that the irregular object does not dissolve or react with the water. You will observe that the level of the water rises for the object has displaced its own volume of water. Then the new level of water in the cylinder is read as  $V_2$ . Thus the volume of the stone, which is the volume of water displaced, is given as

$$V = V_2 - V_1$$

## Method 2

The second method uses the Eureka can otherwise known as the displacement can (fig. 14.8).



**Fig. 14.8**

First the spout of the can is closed with a finger. Then water is poured into the can until the level is above the spout. The finger is then removed thus allowing the excess water above the spout to flow out fig. 14.8(i).

The stone, whose volume is to be measured, is then carefully lowered into the can with the aid of a thread tied to it. It will be observed that the stone will displace water, which gradually flows out of the spout. It flows out until it has displaced the volume of water equal to its own volume (fig. 14.8(ii)).

A measuring cylinder meanwhile has been placed beneath this spout to collect the volume of water that has been displaced thus giving us the reading of the volume of water displaced.

### SELF ASSESSMENT EXERCISE 1

Suppose you are given a light floating irregular object like a cork (wooden). How would you determine its volume?



**Table 14.1: Density of Some Substances**

Substance	Density ( $\rho$ ) ( $\text{gcm}^{-3}$ )
Air	0.0013
Wood	0.6 – 0.9
Water	1.00
Bricks	1.84
Steel	7.80
Gold	19.30

### 3.2 Determination of the Density of an Object

You will recall, we defined density as

$$\text{Density} = \frac{\text{Mass of the Object}}{\text{Volume of the Object}} \dots\dots\dots (14.8)$$

By using the appropriate scale we can determine the mass of an object and using the appropriate method also, we can determine the volume of the object. Thus by dividing the mass of the object by its volume the density of the object can be determined. Therefore, the common units used to express density are  $\text{kg m}^{-3}$ ,  $\text{gcm}^{-3}$  and  $\text{g/m}^3$ . Here first, do some exercises for clear the concept of density.

The density of some substances is given below in tabular 14.1.

#### SELF ASSESSMENT EXERCISE 2

A piece of stone has a mass of 300kg and a volume of  $0.12\text{m}^3$ . What is its density?

#### SELF ASSESSMENT EXERCISE 3

Find the volume of a bottle, which will just hold 63g of seawater of density  $1.05\text{g/cm}^3$ ?

### 3.3 Density of Mixtures

In this section, we shall consider the problems concerned with mixtures of objects such as alloys of metals or mixtures of liquids (water and alcohol). Since different substances have different densities. Other mixtures will include acid solutions that is acid and water, water and milk etc. In science, there is usually the need to have such mixtures and thus determine the densities of such mixtures are useful.

Suppose there are given two substances A and B with the following properties:

### Substance A

$$\begin{aligned}\text{Mass of substance A} &= M_1 \\ \text{Volume of substance A} &= V_1 \\ \text{Density of substance A} &= \rho_1\end{aligned}$$

### Substance B

$$\begin{aligned}\text{Mass of substance B} &= M_2 \\ \text{Volume of substance B} &= V_2 \\ \text{Density of substance B} &= \rho_2\end{aligned}$$

Now the question is: *Suppose the two substances are mixed together how shall we define the density of the mixture ( $\rho$ )?*

The density of the mixture can be represented as

$$\rho = \frac{\text{Mass of A} + \text{mass of B}}{\text{Volume of A} + \text{volume of B}}$$

In terms of the symbols,

$$\therefore \rho = \frac{M_1 + M_2}{V_1 + V_2}$$

$$\text{But } M_1 = \rho_1 V_1 \text{ and } M_2 = \rho_2 V_2$$

$$\therefore \rho = \frac{\rho_1 V_1 + \rho_2 V_2}{V_1 + V_2} \dots\dots\dots (14.9)$$

Thus knowing the values of  $\rho_1$ ,  $V_1$ ,  $\rho_2$  and  $V_2$ , we are in the position to determine the density of the mixture  $\rho$ .

### SELF ASSESSMENT EXERCISE 4

What is the density of a mixture of  $1.5\text{m}^3$  of water and  $0.5\text{m}^3$  of alcohol of density  $800\text{kg/m}^3$ ? (Density of water =  $1000\text{kg/m}^3$ ).s

## 4.0 CONCLUSION

The density of an object is defined as the mass per unit volume of the properties of matter. It tells us how heavy or light an object is relative to water or air. If it sinks in water we say it is heavy, it has a density greater than water. If it floats in water we say it is light with a density lower than that of water. The knowledge of the mass and the volume of the object allow us to operationally define the density of a substance. We have also discussed the density of alloys (mixture of metals) and of solutions (mixture of liquids). We would now consider the concept of buoyancy, Archimedes Principle and the law of flotation in the next unit.

## 5.0 SUMMARY

In this unit, you have learnt the following:

- The concept of density as a property of matter;
- Density is defined as the mass per unit volume of a substance;
- The density of a substance can be determined from the knowledge of its mass and volume;
- The mass of the object may be determined by weighing on a balance or scale;
- The volume of the object may also be determined by using the regular formulae of calculating volumes or by the method of water displacement;
- From the knowledge of mass and volume, the density of the object can be determined;
- How to determine the density of the mixture of two substances.

### ANSWER TO SELF ASSESSMENT EXERCISE 1

You must first realize that the object will not sink in water. It will float. *So what would you do?*

So, to determine the volume of a light, floating object such as a cork, you will use a sinker (a heavy object), which will assist you in the method of displacement. First, you will get our usual measuring cylinder and fill it with water to give an initial volume of water  $V_1$  as shown in fig. 14.9.

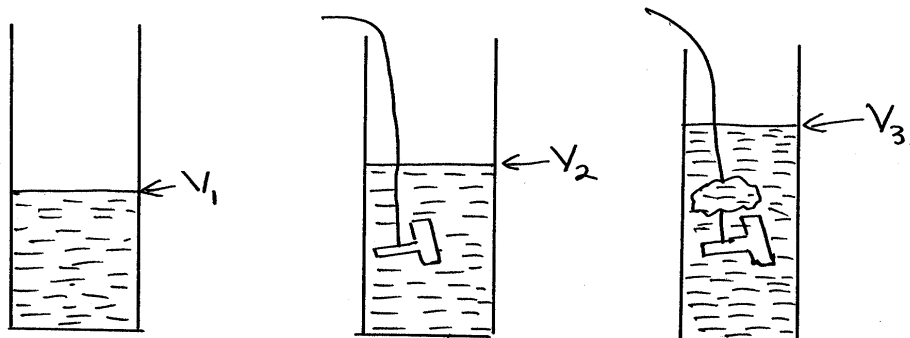


Fig. 14.9

Then you will determine the volume of the sinker by immersing it into the water using a thread. This gives a new volume of water  $V_2$  (fig. 14.9(ii)). *Now what would you consider to be the volume of the sinker alone?*

$$\text{It is } (V_2 - V_1)$$

We bring out the sinker without losing any water. We tie the cork and the sinker together and then immerse the two into the measuring cylinder to produce another volume  $V_3$  (fig. 14.9(iii)).

*Thus what would you consider as the volume of the cork?*

$$\text{The volume of the cork} = V_3 - (V_2 - V_1)$$

Note that the unit of volume is  $\text{cm}^3$  or  $\text{m}^3$ .

## ANSWER TO SELF ASSESSMENT EXERCISE 2

Using the Eq. (14.8), we get

$$\begin{aligned} \text{Density of stone} &= \frac{\text{Mass of Stone}}{\text{Volume of Stone}} \\ &= \frac{300\text{kg}}{0.12\text{m}^3} \\ &= 2500\text{kgm}^{-3} \end{aligned}$$

Note the unit of density as  $\text{kg/m}^3$  or  $\text{kgm}^{-3}$ .

**ANSWER TO SELF ASSESSMENT EXERCISE 3**

$$\text{Density of Sea water} = \frac{\text{Mass of Sea water}}{\text{Volume of Sea water}}$$

$$\therefore \text{Volume of stone} = \frac{\text{Mass of Stone}}{\text{Density of Stone}}$$

$$= \frac{63\text{g}}{1.05 \frac{\text{g}}{\text{cm}^3}}$$

$$= 60\text{cm}^3$$

But the volume of seawater is equal to the volume of the bottle. Therefore, the volume of the bottle is  $60\text{cm}^3$ .

**ANSWER TO SELF ASSESSMENT EXERCISE 4**

The two liquids are water and alcohol.

Where, Density of water =  $\rho_1 = 1000\text{kg/m}^3$

Volume of water =  $V_1 = 1.5\text{m}^3$

Density of alcohol =  $\rho_2 = 800\text{kg/m}^3$

Volume of alcohol =  $V_2 = 0.5\text{m}^3$

$$\therefore \text{Density of mixture} = \rho = \frac{\rho_1 V_1 + \rho_2 V_2}{V_1 + V_2}$$

$$= \frac{1000 \frac{\text{kg}}{\text{m}^3} \times 1.5\text{m}^3 + 800 \frac{\text{kg}}{\text{m}^3} \times 0.5\text{m}^3}{1.5\text{m}^3 + 0.5\text{m}^3}$$

$$= \frac{1500\text{kg} + 400\text{kg}}{2.0\text{m}^3}$$

$$= 950\text{kgm}^{-3}$$

The density of the mixture is  $950\text{kg/m}^3$  or  $950\text{kgm}^{-3}$

## 6.0 TUTOR - MARKED ASSIGNMENT

1. A bottle has a capacity of  $60\text{cm}^3$ . What mass of brine (density =  $1.2\text{g/cm}^3$ ) will it hold?
2. Taking the density of air as  $12\text{kgm}^{-3}$ , find the mass of air that is in a room 6.0m long, 4.0m wide and 2.5m high.
3. Some zinc (density =  $7100\text{kgm}^{-3}$ ) is mixed with twice its volume of copper (density =  $8900\text{kgm}^{-3}$ ) to make brass. What is the density of brass?
4. What volume of water must be added to  $40\text{cm}^3$  of glycerine (density =  $1.3\text{gcm}^{-3}$ ) in order that the mixture shall have a density of  $1.1\text{gcm}^{-3}$ ?

## 7.0 REFERENCES/FURTHER READING

- Awe, O. and Okunola, O.O. (1986). *Comprehensive Certificate Physics*, Ibadan: University Press.
- Ference, M. (Jnr.), Lemon, H.B. and Stephenson, RJ (1970). *Analytical Experimental Physics*, Chicago: The University of Chicago Press.
- Feynman, R.P., Leighton, R.B. and Sands, M (1971). *The Feynman Lectures on Physics*, California: Addison-Wesley Publishing Company.
- Flowers, B.H. and Mendoza, E (1970). *Properties of Matter*, London: John Wiley and Sons Limited.
- Noaks, M.A. (1963). *New Intermediate Physics*, Canada: Macmillan and company Limited.
- Soars, F.W., Zemansky, M.W. and Young, H.D. (1980). *College Physics*. London: Addison-Wesley Publishing Company.
- Tyler, F. (1966). *Heat and Thermodynamics*. London: Edwards Arnold Publisher Limited.
- Wilkinson, J. (1983). *Essentials of Physics*, Australia: Macmillan Education Publisher.
- Zemansky, M.W. (1968). *Heat and Thermodynamics*. New York: McGraw-Hill Book Company.

## UNIT 5 BUOYANCY – ARCHIMEDES PRINCIPLES

### CONTENTS

- 1.0 Introduction
- 2.0 Objectives
- 3.0 Main Content
  - 3.1 Concepts of Buoyancy
  - 3.2 Archimedes' Principle
    - 3.2.1 Test of Archimedes' Principle
    - 3.2.2 Relative Density
    - 3.2.3 Application of Archimedes' Principle
  - 3.3 Measuring the Relative Density of a Liquid Using Archimedes' Principle
  - 3.4 The Law of Floatation
- 4.0 Conclusion
- 5.0 Summary
- 6.0 Tutor-Marked Assignment
- 7.0 References/Further Reading

### 1.0 INTRODUCTION

History has it that the concept of Buoyancy was developed by Archimedes (287 – 212 B.C.). When he solved a riddle for the King of Greece. What was the riddle? The king gave a piece of gold to his goldsmith to make a crown for him. The man came back with the well-made crown. The king was not only impressed by the beautiful crown made, rather, he became suspicious about the quality of the crown made from gold. So the King wanted to determine whether a goldsmith had defrauded him by replacing some of the gold in the crown with silver.

The king, therefore, called on his subjects, his philosophers to solve this problem. When Archimedes went into bathing pools experience the buoyant force and then came out of it rejoicing and shouting “Eureka! Eureka!! ....” Meaning “I have found it”.

What he found out then is what is described now as Archimedes' Principle, which enables us to determine the density of an object by immersing it in a fluid like water. It graduated into the law of floatation, which also help us to explain how huge ships or boats could float on water.

So in this unit, you will learn about the concept of buoyancy, Archimedes' principle and the law of floatation. Come along with me on the discussion.

## 2.0 OBJECTIVES

At the end of the unit you should be able to:

- explain the concept of buoyancy
- state Archimedes' Principle
- define relative density in terms of Archimedes' Principle
- state the law of floatation
- solve problems on Archimedes' Principle and the law of floatation.

## 3.0 MAIN CONTENT

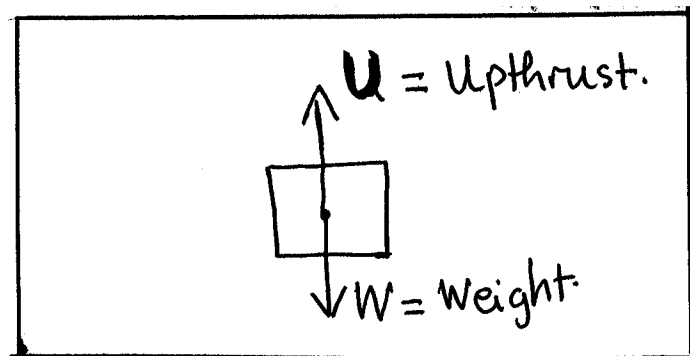
### 3.1 Concepts of Buoyancy

Buoyancy is a concept that describes the floatation of an object in fluids generally. Buoyancy has therefore got to do with the density of the object. In simple words, the ability of an object to 'float' when it is placed in a fluid is called buoyant force. For example, a swimmer experiences this idea of buoyancy, floatation in water as he/she swims in it.

The water supports the body of the swimmer, which makes him appear to weigh less. This is the case with any liquid. This is because when you go into the water, you displace some liquid and the liquid exerts an upthrust on you.

This is also true of gases but because our body would displace a very smaller weight of air, the upthrust is much less. There are three possible situations for a body situated in a fluid as shown in fig. 15.1 below.

*Let us see what you think will happen to the body in these three situations:*



**Fig. 15.1**



- If its weight (W) is greater than the upthrust (U)

The body sinks. For example a stone placed in water.

$$W > U \Rightarrow \text{SINKING OF OBJECT}$$

- Now, if the upthrust (U) is greater than the weight (W)

You are right if you say the body rises. For example, if a helium-filled balloon is left in air, the balloon rises

$$U > W \Rightarrow \text{RISING OF OBJECT}$$

- If the weight (W) of the object balances if is equal to the upthrust (U)

The objects float in the fluid. For example, a boat or a ship floating on the sea.

$$W = U \Rightarrow \text{FLOATING OF OBJECT}$$

These three conditions explain,

- Archimedes’ Principle and
- The law of floatation.

### 3.2 Archimedes’ Principle

**“Archimedes’ Principle states that when a body is either partially or totally immersed in a fluid, it will experience an upthrust equal to the weight of the fluid displaced”.**

Suppose the weight of the body in air is W, when the body is now immersed in a fluid partially or fully, it experiences an upthrust (U). The new weight registered by the scale (A) is now less than that of the air (W). A is called the apparent weight i.e. it appears to be the weight of the object.

The relationship between the apparent weight (A), the upthrust (U) and the actual weight in air (W) is show below.

*Weight in air (W) = Apparent weight in fluid (A) + the upthrust (U) experienced.*

$$\begin{aligned} \therefore W &= A + U \\ \therefore \text{The upthrust } U &= \text{Weight in air (W)} - \text{Weight in fluid (A)} \\ U &= W - A \dots\dots\dots (15.1) \end{aligned}$$

Theoretically, the weight of a body in air is equal to its apparent weight because the displaced air will exert an upthrust but typically, this upthrust is so small compared with its weight that it can be ignored.

Note that the upthrust on the body is equal to the weight of the fluid displaced. This is the essential aspect of Archimedes' principle, which you must always remember.

### 3.2.1 Test of Archimedes' Principle

Is it possible to test if Archimedes' Principle is correct? Yes, it is possible to do so.

- You can weigh an object in air using a spring balance (fig. 15.2(i))
- You will read the scale on the spring balance, which will indicate the weight of the object in air. Record this weight as  $W_1$  (fig. 15.2(ii))
- Immerse the object totally in the Eureka can as shown in fig. 15.2(ii).

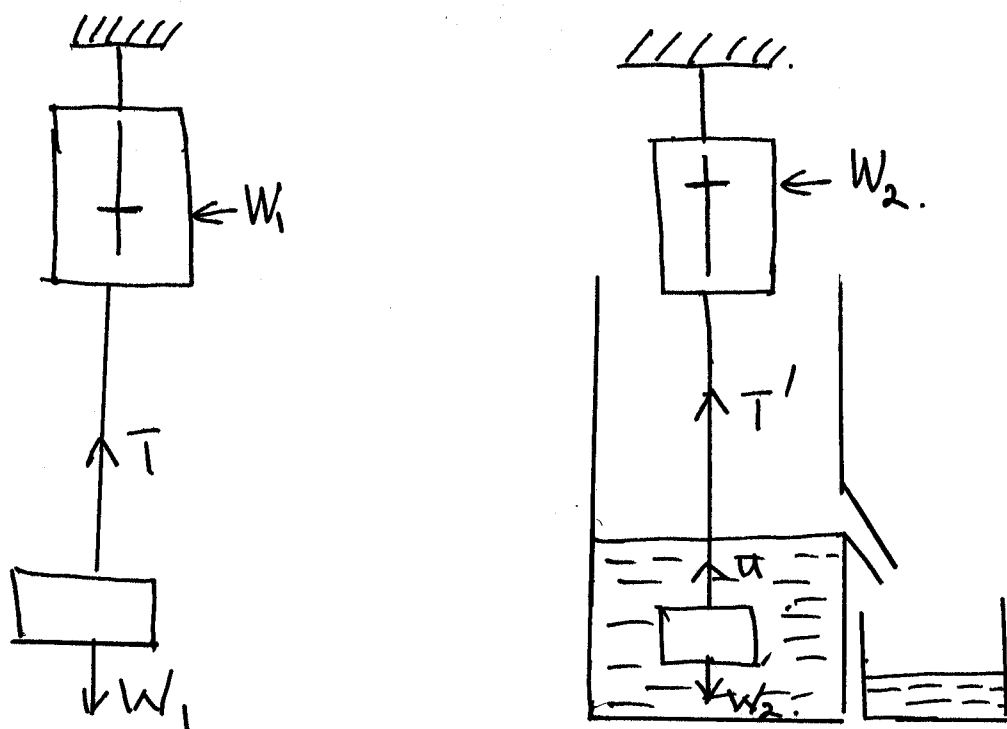


Fig. 15.2

- The water displaced is collected in the measuring cylinder as shown in fig. 15.2(ii)

- Read the new weight of the object when it is fully immersed in water and record it as  $W_2$  (fig. 15.2(ii))
- Weigh the liquid displaced by using the chemical balance by finding the difference between the weight of cylinder and water and the weight of the empty cylinder. Suppose this weight is  $w$ .
- Compare the value of  $w$  with the difference between the weight of the object in air  $w_1$  and the weight of the object  $w_2$  when fully immersed in water
- You will observe that
 
$$W_1 - W_2 = w \dots\dots\dots (15.2)$$

That is, the weight of water displaced  $W$  is equal to the difference between the weight in air of object and the apparent weight in air. That is the weight of displaced fluid is equal to the upthrust  $U$ .

### SELF ASSESSMENT EXERCISE 1

A piece of metal has a volume  $0.50\text{m}^3$ . If it is suspended on a rope and immersed in water, find

- The volume of the displaced water
- Mass of the displaced water
- The weight of the displaced water
- The upward force (upthrust) on the metal due to the water.

### 3.2.2 Relative Density

As you have learnt in Table 14.1 of the preceding unit that then density of water is  $1.00\text{gcm}^{-3}$ . In this table, the densities of other substances are also given. Now we learn what the concept of relative density is.

When we compare the density of a substance with the density of water then we are talking about the relative density of that substance. In other words, we are saying how many times this substance is as heavy as water.

By definition,

$$\text{The Relative Density of a substance} = \frac{\text{The density of the substance}}{\text{The density of water}}$$

Let  $\rho_r$  = The relative density of the substance  
 $\rho$  = The density of the substance  
 $\rho_w$  = the density of water

Therefore, the expression for relative density is

$$\therefore \rho_r = \frac{\rho}{\rho_w} \dots\dots\dots (15.3)$$

$$\therefore \rho = \rho_r \rho_w \dots\dots\dots (15.4)$$

That is the actual density of a substance is equal to the relative density of the substance times the density of water. It can be noted from the definition of relative density, that it has no unit since it is a ratio.

### 3.2.3 Application of Archimedes' Principle

From the definition of relative density,

$$\begin{aligned} \text{Relative Density} &= \frac{\text{Density of the substance}}{\text{Density of water}} \\ &= \frac{\frac{\text{Mass of substance}}{\text{Volume of substance}}}{\frac{\text{Mass of water displaced}}{\text{Volume of water displaced}}} \end{aligned}$$

- Let,  $m_1$  = mass of substance
- $V_1$  = volume of substance
- $M_2$  = mass of water displaced
- $V_2$  = volume of water displaced
- $\rho_r$  = relative density of substance

$$\therefore \rho_r = \frac{m_1}{V_1} + \frac{m_2}{V_2}$$

$$\begin{aligned} \therefore \rho_r &= \frac{m_1}{V_1} \times \frac{V_2}{m_2} \\ &= \frac{m_1}{m_2} + \frac{V_2}{V_1} \end{aligned}$$

But the volume of water displaced  $V_2$  is equal to the volume of the substance  $V_1$ .

$$\therefore \rho_r = \frac{m_1}{m_2}$$

Hence the relative density of a substance can be defined as

$$\therefore \rho_r = \frac{\text{Mass of the substance}}{\text{Mass of an equal volume of water}}$$

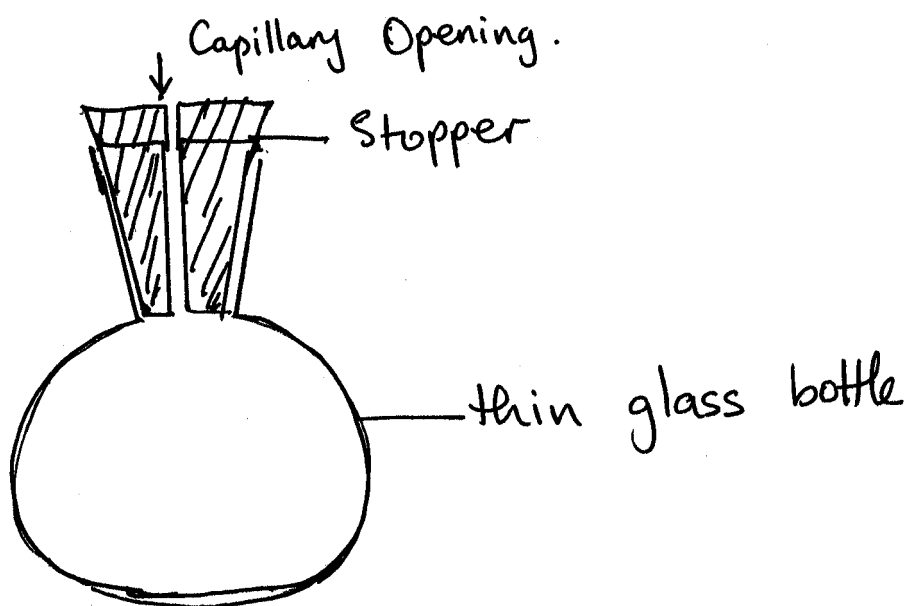
$$\text{Hence } \rho_r = \frac{m_1}{m_2}$$

Alternatively,

$$\rho_r = \frac{\text{Weight of the substance}}{\text{Weight of an equal volume of water}}$$

$$\rho_r = \frac{W_1}{W_2} = \frac{m_1 g}{m_2 g} \dots\dots\dots (15.5)$$

We apply the concept of relative density to derive the density of a solids or a liquid. The specific gravity bottle or relative density bottle is used in determining the relative densities of liquids (fig. 15.3).



**Fig. 15.3: Relative Density Bottle**

The relative density bottle is a special stopper, which ensures constant volume of the liquid to be measured. The stopper has a narrow opening which allows excess liquid flow out when the bottle is closed. Thus the bottle will hold a specific volume of liquid at the time it is used. Usually the volume of such bottle varies. It could be  $25\text{cm}^3$ ,  $50\text{cm}^3$  or  $75\text{cm}^3$  capacity. It is usually picked by the neck to avoid the expansion of the liquid because the glass bottle is so thin that it is sensitive to temperature changes, which, may cause the expansion of the liquid.

**SELF ASSESSMENT EXERCISE 2**

A stone hangs from a spring balance graduated in Newton's, and the reading is 30N. If the stone is immersed in water, the reading becomes 18N. Determine density of the stone?

The following example relates to the determination of the density of a liquid through the application of relative density.

**SELF ASSESSMENT EXERCISE 3**

A density bottle has a mass of 12.3g when empty 14.8g when filled with water and 32.1g when filled with turpentine. What is the density of turpentine?

**3.3 Measuring the Relative Density of a Liquid Using Archimedes' Principle**

In section 3.2.3, you have applied the concept of relative density to derive the density of a solid or a liquid. The specific gravity bottle is used in determining the relative densities of liquid. But can you determine the relative density of liquid by using the other methods? Let us discuss it; suppose you are asked to determine the relative density of liquid using the Archimedes' Principle, how would you do this?

To do this, you will require an object that sinks in water and the liquid, which is insoluble in both water, and the liquid (paraffin).

You will need a spiral spring balance to measure the weight of the solid object when immersed in water and the liquid.

- First weigh the solid in air using the spring balance
- Record this weight as  $W_1$
- Then weigh the solid in the liquid using the spring balance
- Record this weight  $W_2$
- Wipe the solid properly free from the liquid and then weigh it in the water using the spring balance
- Record the weight of the solid in water as  $W_3$

Now determine what is the weight of the water displaced by the solid? The weight of liquid displaced by the solid =  $W_1 - W_2$ .

Again, what is the weight of the water displaced by the solid? Weight of water displaced by the solid =  $W_1 - W_3$ . Therefore, by definition, the relative density of the liquid,

$$= \frac{\text{Weight of the liquid displaced}}{\text{Weight of equal volume of water}}$$

$$= \frac{W_1 - W_2}{W_1 - W_3} \dots\dots\dots (15.6)$$

**SELF ASSESSMENT EXERCISE 4**

A block of aluminum of volume 0.25m<sup>3</sup> hangs from a wire and the tension in the wire is 6500N. If the block is completely immersed in a liquid of density 1100kgm<sup>-2</sup>. Calculate the tension in the wire.

**3.4 The Law of Floatation**

*What does the law of floatation states?*

**“The law of floatation states that a floating body displaces its own weight of the liquid in which it floats”.**

This is really a special case of Archimedes’ Principle and it is the situation in which the weight of the body is exactly balanced by the upthrust from the fluid. This therefore implies that if a body is to float, it must displace its own weight of the fluid in which it is floating.

You should remember that if a body is floating in a liquid, the body is likely to float with certain amount of itself above the fluid or it is totally immersed. A floating ice block in water and a floating balloon in air are typical examples.

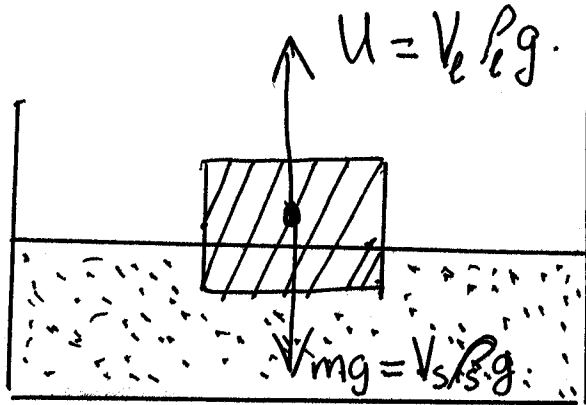
**SELF ASSESSMENT EXERCISE 5**

A boat of mass 650kg floats on water, what volume of water does it displace?

When an object at rest floats on a liquid, it is described to be in equilibrium under the action of two forces, namely:

- Its weight (W) and
- Its buoyant force or upthrust (U) which is equal to the weight of the liquid displaced (fig. 15.4)

In accordance with the Archimedes’ Principle  
 Weight of substance = Weight of liquid displaced



**Fig. 15.4**

Weight of object = Upthrust = weight of liquid displaced  
 $Mg = U$   
 $V_S \rho_S g = V_L \rho_L g \dots\dots\dots (15.7)$

Where,  $V_S$  = volume of solid floating  
 $\rho_S$  = density of solid floating  
 $V_L$  = volume of liquid displaced  
 $\rho_L$  = density of liquid displaced  
 $g$  = acceleration due to gravity

$\therefore V_S \rho_S = V_L \rho_L$

$$\frac{\rho_S}{\rho_L} = \frac{V_L}{V_S} = \rho_r$$

Volume of liquid displaced is equal to volume of solid

$$= \frac{\text{Mass of solid}}{\text{Mass of equal volume of liquid displaced}} \dots\dots\dots (15.8)$$

$$= \frac{\text{Weight of solid}}{\text{Weight of equal volume of liquid displaced}} \dots\dots\dots (15.9)$$

**SELF ASSESSMENT EXERCISE 6**

An iceberg floats with 87% of its volume above the sea water, the density of which is  $1.03\text{g/cm}^3$ . Determine the density of the ice.



## 4.0 CONCLUSION

When a body is fully or partially immersed in a fluid, it experiences an upward force called the upthrust. This upthrust is equal to the weight of the liquid displaced. There is a special case for this principle and that is when the entire body is made to float in the fluid. The law of floatation explains this, which states that the upthrust experienced by the floating object is equal to the entire weight of the floating objects. The Archimedes' principle and the law of floatation form the embodiment of the concept known as buoyancy.

## 5.0 SUMMARY

In this unit, you have learnt that:

- Buoyancy is the ability of an object to float, sink or rise in a fluid;
- Archimedes' Principle explains how a substance behaves when it is fully immersed in a fluid; and
- The law of floatation also explains how the big ships or boats can float on waters without sinking despite their weight or mass.

### ANSWER TO SELF ASSESSMENT EXERCISE 1

- (a) Since the volume of the metal is  $0.5\text{m}^3$ , the volume of water displaced is  $0.5\text{m}^3$ . This is due to Archimedes' Principle.
- (b) Mass of displaced water is equal to volume of water displaced times its density
- $$\begin{aligned} m &= \text{Volume} \times \text{density} \\ &= 0.5\text{m}^3 \times 1000\text{kg/m}^3 \\ &= 500\text{kg} \end{aligned}$$
- (c) Weight of the displaced water
- $$\begin{aligned} &= mg \\ &= 500\text{kg} \times 10\text{m/s}^2 \\ &= 5000\text{kgm/s}^2 \\ &= 5000\text{N} \end{aligned}$$
- (d) The upward force (upthrust)
- $$\begin{aligned} &= \text{weight of water displaced} \\ &= \mathbf{5000\text{N}} \end{aligned}$$

**ANSWER TO SELF ASSESSMENT EXERCISE 2**

If weight of stone in air =  $W_1 = 30\text{N}$

And weight of stone in water =  $W_2 = 18\text{N}$

$$\begin{aligned} \therefore \text{The upthrust on the stone} &= W_1 - W_2 \\ &= 30\text{N} - 18\text{N} \\ &= 12\text{N} \end{aligned}$$

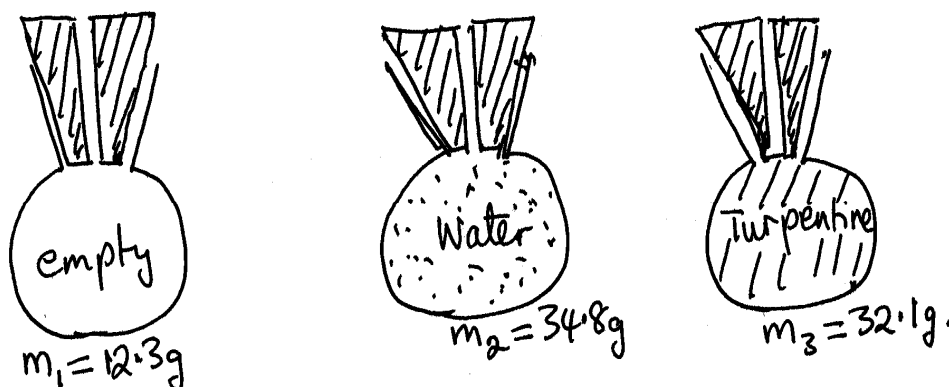
Which is equal to the weight of equal volume of water displaced by the stone.

$$\begin{aligned} \text{Relative density of stone} &= \frac{\text{Weight in air}}{\text{Upthrust}} \\ &= \frac{\text{Weight in air}}{\text{Weight of equal volume of water}} \\ &= \frac{30}{12} \end{aligned}$$

$$\therefore \rho_r = 2.5$$

$$\begin{aligned} \therefore \rho \text{ of stone} &= \rho_r \rho_w \\ &= 2.5 \times 1000\text{kg/m}^3 \\ &= 2500\text{kg/m}^3 \end{aligned}$$

Density of stone = **2500kg/m<sup>3</sup>**

**ANSWER TO SELF ASSESSMENT EXERCISE 3**

**Fig. 15.5**

Density of turpentine = relative density of turpentine x density of water

$$\text{Relative density of turpentine} = \frac{\text{Mass of Turpentine}}{\text{Mass of equal volume of water}}$$

Mass of turpentine =  $m_3 - m_1$

Mass of equal volume of water =  $m_2 - m_1$

$$\text{Relative density of turpentine} = \frac{m_3 - m_1}{m_2 - m_1}$$

$$= \frac{(32.1 - 12.3)\text{g}}{(34.8 - 12.3)\text{g}}$$

$$= \frac{19.8\text{g}}{0.88}$$

Density of turpentine = relative density of turpentine x density of water

$$\begin{aligned} \text{(where, density of water} &= 1\text{gcm}^{-3}\text{)} \\ &= 0.88 \times 1\text{gcm}^{-3} \\ &= \mathbf{0.88\text{g/cm}^3} \end{aligned}$$

#### ANSWER TO SELF ASSESSMENT EXERCISE 4

If the volume of Aluminum is  $0.25\text{m}^3$  then it will displace this volume of the liquid of density  $1100\text{kgm}^{-3}$

$$\begin{aligned} \therefore \text{Mass of liquid displaced} &= \text{volume} \times \text{density} \\ &= 0.25\text{m}^3 \times 1100\text{kgm}^{-3} \\ &= 275\text{kg} \end{aligned}$$

$$\begin{aligned} \therefore \text{Mass of liquid displaced} &= \text{mg} \\ &= 275\text{kg} \times 10\text{ms}^{-2} \\ &= 2750\text{N} \end{aligned}$$

This is therefore the upthrust according to Archimedes' Principle

But, weight of object in air = Apparent weight + upthrust

$$\begin{aligned} \therefore \text{Apparent weight of aluminum} &= \text{Tension in air} - \text{Upthrust} \\ &= 6500\text{N} - 2750\text{N} \\ &= \mathbf{3750\text{N}} \end{aligned}$$

#### ANSWER TO SELF ASSESSMENT EXERCISE 5

Since it floats on water then its weight = upthrust

It will then displace the mass of water equal to its own mass

Thus the mass of water displaced = 650kg

If the density of water =  $1000\text{kg/m}^3$

$$\begin{aligned} \therefore \text{Volume of water displaced} &= \frac{\text{Mass of water}}{\text{Density of water}} \\ &= \frac{650\text{kg}}{1000 \frac{\text{kg}}{\text{m}^3}} \\ &= 0.650\text{m}^3 \end{aligned}$$

$$\therefore \text{Volume of water displaced} = 0.650\text{m}^3$$

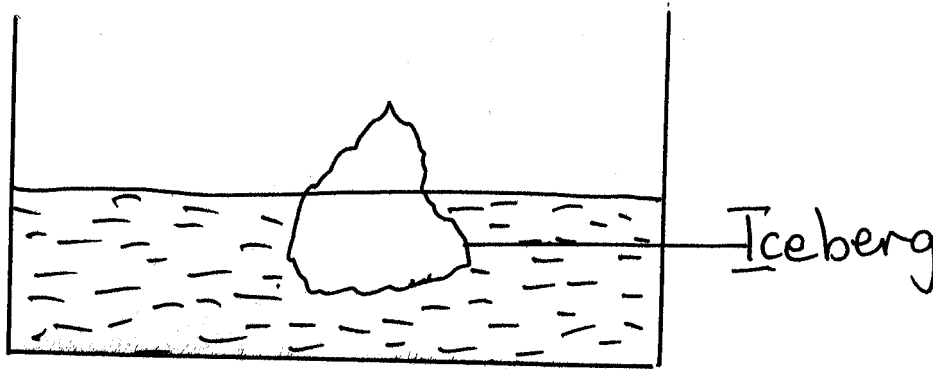
**ANSWER TO SELF ASSESSMENT EXERCISE 6**

Let  $V$  be the volume of the iceberg

Let  $\rho$  be the density of the iceberg

Taking  $g$  as the acceleration due to gravity

Weight of iceberg =  $V\rho g$



**Fig. 15.6**

The weight of water displaced =  $\rho_w V_w g$

Where,  $\rho_w$  = density of sea water

$V_w$  = volume of water displaced

We were told that 10.87% of the iceberg is above sea water

$$\begin{aligned} \therefore \text{Volume of iceberg below sea} &= \left( \frac{100 - 10.87}{100} \right) V \\ &= \frac{89.13}{100} V \end{aligned}$$

$$\therefore V_w = \frac{89.13}{100} V$$

$$\therefore \text{Volume of sea water displaced} = \frac{89.13}{100} V$$

$$\begin{aligned} \therefore \text{Weight of liquid} &= \rho_{\text{sea}} V_{\text{sea}} g \\ &= 1.03 \frac{\text{g}}{\text{cm}^3} \times \frac{89.13}{100} V g \end{aligned}$$

But weight of ice = weight of sea water displaced

$$\therefore \rho V g = 1.03 \frac{\text{g}}{\text{cm}^3} \times \frac{89.13}{100} V g$$

$$\therefore \rho = 1.03 \times \frac{89.13}{100} \frac{\text{g}}{\text{cm}^3}$$

$$\therefore \rho = 1.918 \text{g/cm}^3$$

**6.0 TUTOR-MARKED ASSIGNMENT**

1. A piece of metal has a volume of  $0.75\text{m}^3$ . It is suspended on a rope and immersed in glycerine of density  $1200\text{kgm}^{-3}$  find
  - (a) The volume of glycerine displaced
  - (b) The mass of the glycerine displaced
  - (c) The weight of the displaced glycerine
  - (d) The upward force (upthrust) on the metal due to the glycerine
2. A piece of rock salt weighs  $3.3\text{N}$  in air and appears to weigh  $1.5\text{N}$  when immersed in saturated salt solution of density  $1200\text{kgm}^{-3}$ , what is the density of the rock salt?
3. Full of water, a large flask has a mass of  $3.5\text{kg}$ , and when full of the diesel oil, the mass is  $3.2\text{kg}$ . What is the density of the diesel oil if the flask alone has a mass of  $1.5\text{kg}$ ?
4. A wooden block of volume  $100\text{cm}^3$  and density  $0.7\text{gcm}^{-3}$  is floating in brine of density  $1.2\text{g/cm}^3$ . What is the mass of a body which when placed on top of the block will push it below the surface of the brine?

## 7.0 REFERENCES/FURTHER READING

- Awe, O. and Okunola, O.O. (1986). *Comprehensive Certificate Physics*, Ibadan: University Press.
- Ference, M. (Jnr.), Lemon, H.B. and Stephenson, RJ (1970). *Analytical Experimental Physics*, Chicago: The University of Chicago Press.
- Feynman, R.P., Leighton, R.B. and Sands, M (1971). *The Feynman Lectures on Physics*, California: Addison-Wesley Publishing Company Limited.
- Flowers, B.H. and Mendoza, E (1970). *Properties of Matter*, London: John Wiley and Sons Limited.
- Noaks, M.A. (1963). *New Intermediate Physics*, Canada: Macmillan and company Limited.
- Soars, F.W., Zemansky, M.W. and Young, H.D. (1980). *College Physics*. London: Addison-Wesley Publishing Company.
- Tyler, F. (1966). *Heat and Thermodynamics*. London: Edwards Arnold Publisher Limited.

**MODULE 4**

Unit 1	Pressure
Unit 2	Elements of Hydrodynamics
Unit 3	Viscosity of Fluids
Unit 4	Surface Tension
Unit 5	Other Properties of Gases

**UNIT 1 PRESSURE****CONTENTS**

1.0	Introduction
2.0	Objectives
3.0	Main Content
3.1	Concepts of Pressure in Matter
3.2	Concepts of Pressure in Fluids
3.2.1	Force of Pressure in Liquids
3.2.2	Pressure Due to the Weight of a Liquid Column
3.2.3	Atmosphere Pressure
3.3	Transmission of Pressure in Fluids
3.3.1	Pascal's Principle
3.3.2	Applications of Pascal's Principle
3.4	Measuring Pressure
3.4.1	The Manometer
3.4.2	The Simple Barometer
3.5	The Hare's Apparatus
4.0	Conclusion
5.0	Summary
6.0	Tutor-Marked Assignment
7.0	References/Further Reading

**1.0 INTRODUCTION**

You may have known that the word pressure is commonly used in every day life when you travel. The bags and suitcases are provided with broad handles, so that small pressure exerted can be hard while carrying them.

- In the medical profession blood pressure of the patient being made use of to diagnose patients ailment;
- At home, when water in the tap is not running as fast as it should, occupants may complain about low pressure behind the taps;
- In engineering, physicist and science as a whole the concept of pressure continues to reoccur in one way or the other. The

pressure exists everywhere, but sometimes we don't feel it, like the atmospheric pressure on our bodies.

So, by now you must be thinking what exactly is the meaning of pressure? Why is its knowledge important to us in life?

The answers to these questions will be found in this unit. In this unit, you will be introduced to the concept of pressure, the applications of transmission of pressure and how it is measured. In the next unit, you will learn about elements of Hydrodynamics. The focus of this unit will be on Bernoulli's Principle and its applications.

## 2.0 OBJECTIVES

At the end of this unit, you should be able to:

- explain the concept of pressure
- define the pressure exerted by a solid or fluid using the appropriate units
- explain the transmission of pressure through liquids;
- state Pascal's principle
- mention some applications of Pascal's principles
- derive an expression for the pressure due to the column of a liquid
- measure atmospheric pressure by using a manometer or barometer
- measure relative density by using the pressure method (Hare's apparatus)
- solve problems on pressure.

## 3.0 MAIN CONTENT

### 3.1 Concepts of Pressure in Matter

Let us discuss simple examples which we experience in everyday life. Have you ever been stepped upon by a lady wearing a stiletto-heeled shoe? Can you compare the pain with that experienced with another lady wearing a wider non-stiletto-heeled shoe?

A stiletto-heeled shoe is a type of shoe worn by ladies which has a sharp pointed heel. You must have realized that the pain from such a shoe is greater than that from a shoe with a wider surfaced heel.

Again, how would you compare the pain given by a slim/moderate lady wearing a stiletto shoe with that of a very fat lady?



So two factors are responsible for the gravity of the pain: the force (weight) and the surface area of the heels. The gravity of the pain is associated with the concept of pressure, the force and the surface are affected. So, one can say that Pressure is related to force and area.

Pressure is the force exerted by a body per unit surface area. Pressure is defined as

$$\text{Pressure} = \frac{\text{Force}}{\text{Area}}$$

Mathematically, it can be expressed as

$$P = \frac{F}{A} \dots\dots\dots (16.1)$$

Where, F is the force and A is the area.

The force is usually measured in Newton (N) whereas area in meter square ( $\text{m}^2$ ).

$$\therefore P = \frac{F}{A}$$

The force is measured in terms Newton (N) and the unit of Area is metre-square ( $\text{m}^2$ ). Hence, the unit of pressure is  $\text{Nm}^{-2}$ , which also called Pascal (Pa) in memory of the scientist that worked on pressure Blaise Pascal (1623 – 1662).

### SELF ASSESSMENT EXERCISE 1

A cubical block of concrete edge 0.25m, rests on a horizontal surface. If its weight is 300N, what pressure does it exert on the surface?

### 3.2 Concepts of Pressure in Fluids

The main distinctive feature of fluids in comparison with solid (elastic) bodies is their mobility (fluidity) – that is they flow. Owing to their mobility, fluids, unlike elastic bodies, do not offer a resistance to changes in their shapes. Parts of a liquid can move freely sliding relative to one another.

The mobility of liquids therefore explains why the free surface of a liquid in equilibrium under the force of gravity is always horizontal. If for example, the surface of a liquid at rest were at an angle to the horizontal, the particles of a liquid near the surface would slide down along the surface under the action of gravity like being along an inclined plane. Such a motion would continue until the surface of the liquid becomes horizontal.

The free surface of a liquid in a vessel is slightly bent near the walls of the container. The bending is due to the force of interaction between the liquid and the walls. We describe this surface as the meniscus of the liquid surface. The effect will be fully discussed under surface tension. Another property of liquids is the pressure, which therefore leads us to the concept of pressure in liquids.

### 3.2.1 Force of Pressure in Liquids

Pressure is the force exerted on a unit area of the surface. It has been observed that liquid exert certain forces on the surface of solids in contact with them. These forces are referred to as forces of hydrostatics pressure. If you use your finger to close a tap of water, you will feel this pressure. A diver at a large depth in the sea experiences pains in his ears, which is caused by the forces of pressure of water in his ear-drums. Thermometers used in measuring temperatures at a large sea depth must be very strong, otherwise water pressure can crush them.

It will be observed also that liquids are incompressible, volume does not change under high pressures.

The pressure in the lower part of a vessel is higher than that in the upper part. This is observed when water contained in a jar is allowed to flow out of a vessel at different points along the height of the vessel (fig. 16.1).

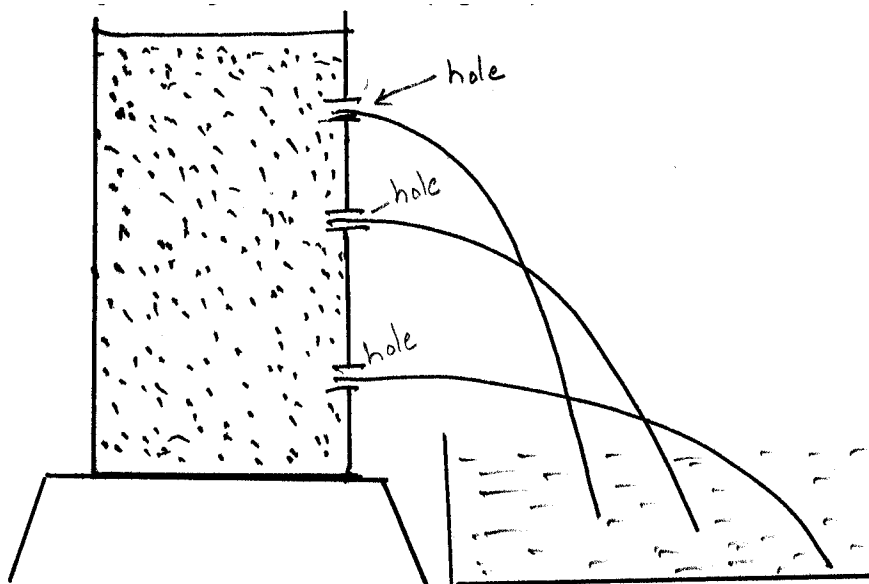


Fig. 16.1

If the holes of the vessel are sealed with thin membranes, it will be observed that the membranes bulge out with the thrust of the pressure on them as you can see in fig. 16.2.



**Fig. 16.2**

The thrust is greatest where the pressure is greatest. This further demonstrates the fact that pressure varies with the depth of a liquid. ***But now the question you may ask: what is the value of the pressure in a liquid at a given depth of it?***

In the subsequent section, you will find the answer. In this next section, we shall derive an expression for the magnitude of pressure due to the weight of liquid.

### **3.2.2 Pressure Due to the Weight of a Liquid Column**

The atoms or molecules of which a liquid is composed are attracted to the earth in accordance with Newton's law of universal gravitation. Hence, liquids collect at the bottom of the containers and the upper layers exert forces on those underneath. We shall now derive an expression for the magnitude of this pressure due to the weight of the liquid. The pressure at a point in a liquid is the force per unit area of a surface at the point in question. This force depends on the weight of the liquid column above the point.

Consider a liquid in a container as shown in fig. 16.3, we now want to find out the magnitude of the pressure at point Q exerted by a column of PQ of the liquid such that Q is at a height  $h$  from the surface of the liquid.

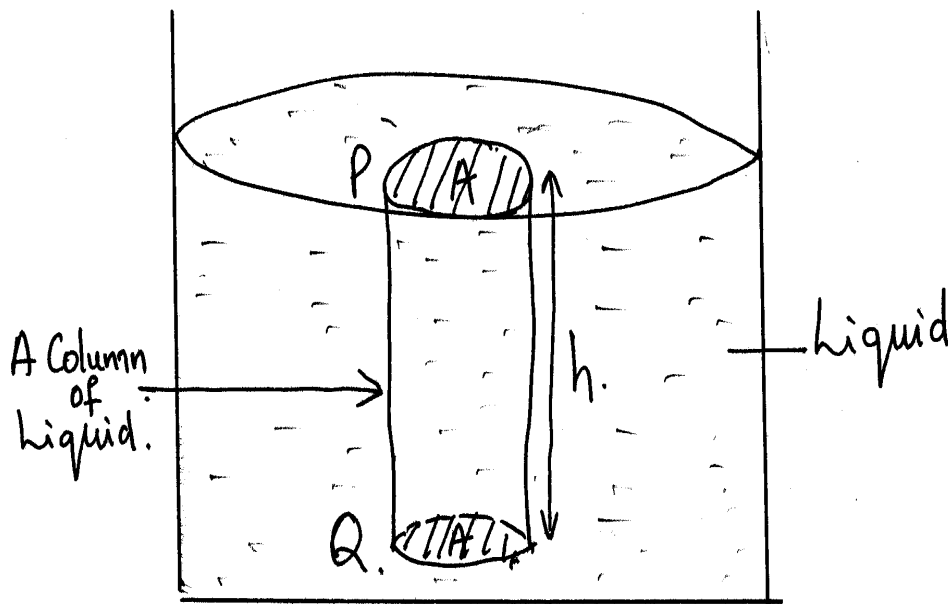


Fig. 16.3

Let the cross-sectional area of the column PQ be A.

Note that this area A is arbitrary. It could be rectangular in shape. As we proceed with this derivation it will be observed that the area A could be any shape. This will not affect the derivation of the pressure.

Let  $\rho$  be the density of liquid. Now, determine the volume of this column of the liquid.

The volume  $V = \text{area of cross-section} \times \text{height of column} = A \times h$

From the definition of density, the mass of the liquid column

$$M = \text{volume} \times \text{density} = Ah\rho g \dots\dots\dots (16.2)$$

Where, g is the acceleration due to gravity.

According to the definition of pressure,

$$\text{PRESSURE} = \frac{\text{FORCE}}{\text{AREA}} = \frac{\text{Weight of Liquid}}{\text{Area of column}}$$

$$\therefore P = \frac{W}{A} = \frac{Ah\rho g}{A} \dots\dots\dots (16.3)$$

$$P = h\rho g \dots\dots\dots (16.4)$$

Thus the hydrostatic pressure of the liquid at point Q is the product of the height (h), the density ( $\rho$ ) of the liquid and acceleration due to gravity (g). The value of pressure is independent of the area of the cross-section. The unit of pressure is still  $\text{Nm}^{-2}$  or Pascal, since the unit of force is Newton and the unit of area is meter square.

From,  $P = h\rho g$ , note that  $\rho$  is a constant,  $g$  is also a constant. Hence, the pressure  $P$  of the liquid is proportional to its height or depth.

$$P \propto h$$

This is why the pressure due to the mercury head is expressed in form of its height.

### SELF ASSESSMENT EXERCISE 2

Kerosene is supplied to a tap from a tank in which the kerosene level is 1.2m above the tap. If the density of kerosene is  $800\text{kgm}^{-3}$ . Calculate pressure of the kerosene at the tap.

### 3.2.3 Atmosphere Pressure

Just as liquids exert pressure, gases also exert pressure. The pressure due to air around us is described as atmospheric pressure. The tiny particles of gases that make up the atmosphere of the earth have weight and as a result exert pressure on all objects on earth just as we have derived the pressure of a liquid on all objects on earth. Just as we have derived the pressure of a liquid column, we can also say that the pressure due to an air column is given as

$$P = h\rho g$$

Air pressure varied therefore with altitude. The higher we go, the lower the pressure. Air pressure is highest at sea level. The value of atmospheric pressure on the surface of earth at sea level is nearly  $1013 \times 10^5\text{Pa}$ .

The air pressure – atmospheric pressure is usually denoted as  $P_0$  or  $h_0$ , where  $h_0$  is the barometric height as shown by the barometer. That is the height of mercury, which the air pressure can maintain in a tube filled with mercury. Therefore, when a diver or any object is at depth  $h$  below the sea level, the total pressure on such a diver or object is made up of

- The atmospheric pressure  $P_0$  or  $h_0$  and
- The pressure due to the liquid itself  $P_1$  or  $h_1$
- Hence, the total pressure  $P$  on the object is given as

$$P = P_0 + P_1$$

Note that  $P_0$  or  $h_0$  is always given in reference to the height of mercury, therefore the units of pressure must be same.

### SELF ASSESSMENT EXERCISE 3

Find the pressure on a diver working at the depth of 10m in the sea on a day when the barometer stands at 750mmHg.

(Density of sea water =  $1050\text{kgm}^{-3}$ ). Express your answer in (a) mmHg and (b)  $\text{Nm}^{-2}$ .

### 3.3 Transmission of Pressure in Fluids

The forces of pressure are transmitted in a liquid in all directions. The forces of pressure are exerted by a liquid not only on the bottom and on the piston but also on the vessels walls (fig. 16.4).

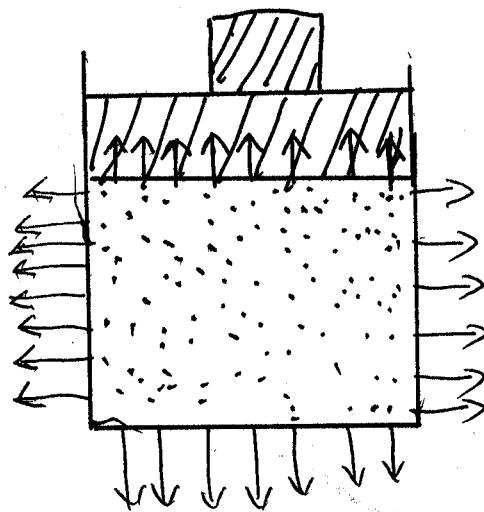


Fig. 16.4

This is why, when membranes are used to cover the holes in the wall of the vessel in fig. 16.2, there are noticeable bulges at the side of wall due to the forces of pressure exerted by water.

#### 3.3.1 Pascal's Principle

Pascal's Principle has got to do with the transmission of pressure in fluids.

**Pascal's Principle states that "Pressure applied to any point to a fluid in a closed vessel is transmitted equally to every other point in the fluid".**

Another way to express the principle is as follows:

*"The pressure exerted by surface forces is transmitted without loss to any point of a liquid".*

This is the principle used in the construction of the hydraulic press in engineering.

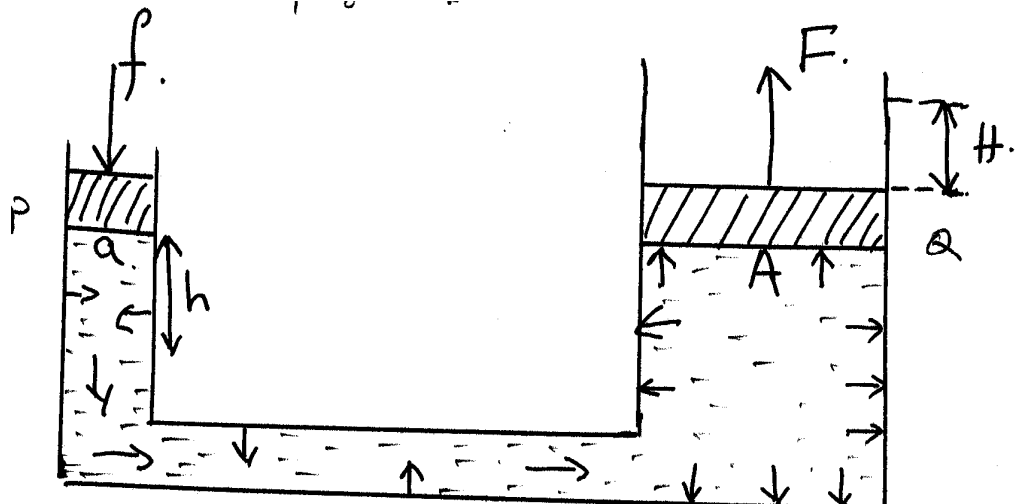
**3.3.2 Applications of Pascal’s Principle**

Pascal’s Principle is applied in the following machines,

- The hydraulic press
- The hydraulic jack
- The hydraulic brakes

The hydraulic press will be discussed here. The hydraulic press has many applications like to compress soft materials like cotton, cloth, paper, etc. into soft bales.

The press consists of two type of cylinders, P and Q connected by a horizontal tube R as shown in fig. 16.5



**Fig. 16.5**

The entire system is filled with a fluid such as water or oil. Let the applied force *f*, the effort be applied on the piston with area *a*. The pressure *P* on the liquid is,

$$P = \frac{f}{a} \dots\dots\dots (16.5)$$

According to Pascal’s Principle, the same pressure will be developed on the load of with area *A*. then,

$$P = \frac{F}{A} \dots\dots\dots (16.6)$$

Since the pressure are the same,

$$\begin{aligned} \therefore \quad \frac{f}{a} &= \frac{F}{A} \\ \therefore \quad \frac{F}{f} &= \frac{A}{a} \dots\dots\dots (17.6) \end{aligned}$$

#### SELF ASSESSMENT EXERCISE 4

Suppose the effort  $f$  is 150N. The surface are of a small piston  $a$  is  $0.01\text{m}^2$  and the surface area of the big piston  $A$  is  $0.1\text{m}^2$ . Calculate the magnitude of the load  $F$ .

The hydraulic press is a simple machine in which when work is done by the effort  $f$  by moving through distance  $h$ , while the load moves through a distance  $H$  (fig. 3.8). In theses case, the efficiency of the hydraulic press  $E$  is defined as

$$\begin{aligned} E &= \frac{\text{Work done by load (F)}}{\text{Work done by effort (f)}} \times 100\% \\ &= \frac{F \cdot H}{f \cdot h} \times 100\% \end{aligned}$$

Suppose the ratio of  $H:h = 1:12$ . What is the efficiency of the hydraulic press.

$$\begin{aligned} \text{The efficiency} &= \frac{1500\text{N} \times 1}{150\text{N} \times 12} \times 100\% \\ &= 83.3\% \end{aligned}$$

So far we have discussed, the concept of pressure, atmospheric pressure, pressure due to the weight of a liquid column. Pascal's law and its applications. But in the next section, we will learn how do we measure pressure?

### 3.4 Measuring Pressure

The medical doctor uses the instrument called sphygmomanometer (Sphyg) to measure the human blood pressure. Next time you visit the doctor ask him to show you his/her "sphyg" and then ask him/her how the "sphyg" is operated and what it is made up of.



However in the laboratories we make use of the manometer to measure pressure due to gas and the barometer to measure the atmospheric pressure.

Basically, the “sphyg”, the manometer and the barometer make use of the height of mercury column that can be held by the magnitude of the pressure in question. We shall describe the manometer and the barometer.

### 3.4.1 The Manometer

The manometer is made up of a U-tube open at both ends filled with mercury or any other liquid (fig. 16.6)

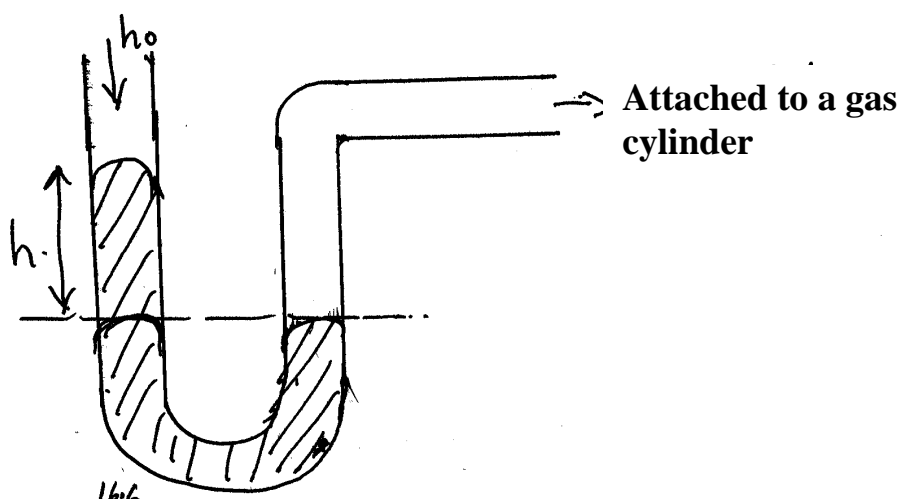
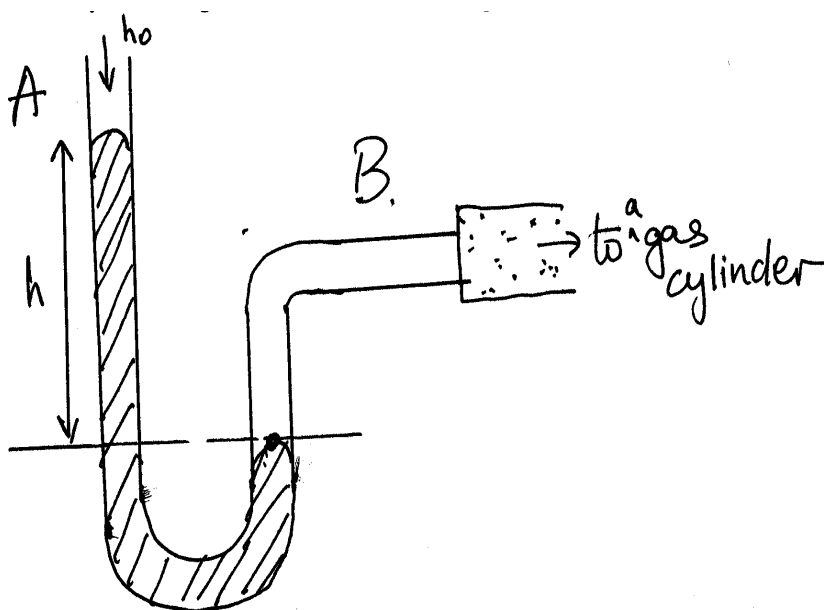


Fig. 16.6: Manometer

You will observe that the mercury reads in both arms of the U-tube are on the same level. That is atmospheric pressure.

Suppose we want to measure the pressure of the gas from a cylinder, then, we connect end B of the U-tube of the cylinder using a rubber tube as shown in fig. 16.7



**Fig. 16.7**

The mercury level rises to a height  $h$  in the A arm of the U-tube. The total pressure of the gas is then equal to that due to the mercury head  $h$  and that of the atmosphere  $h_0$ .

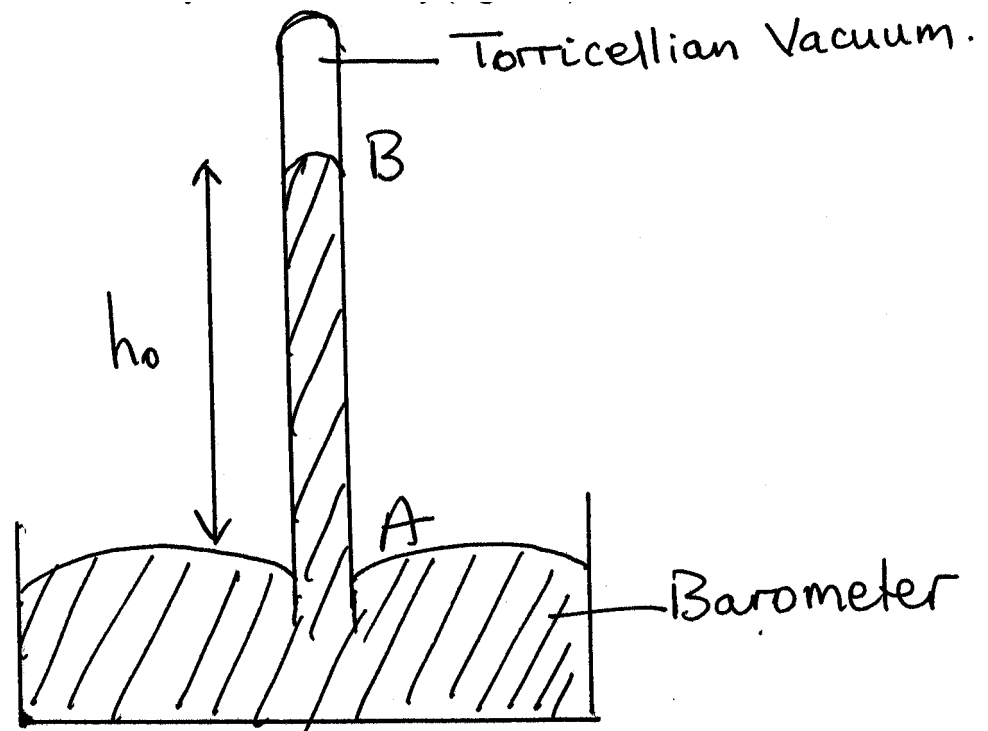
The pressure due to  $h$  is given as  $P = h\rho g$

*The question is how do we measure the atmospheric pressure itself? We use the barometer and what is a barometer? Now we will learn about barometer in the next section.*

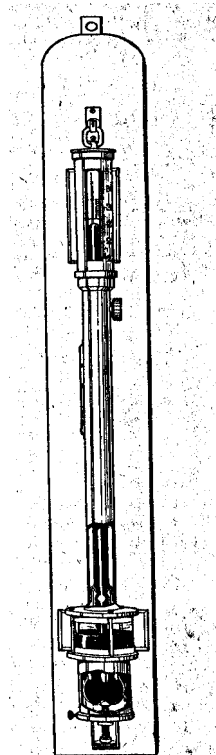
### 3.4.2 The Simple/Mercury Barometer

A mercury barometer is used to measure the atmospheric pressure. It is made up of a straight glass tube, sealed at one end of about one meter long. It is filled with mercury after it has been cleaned and dried.

The tube filled with mercury is turned several times to ensure that no air bubbles reside in the tube. When the mercury is filled properly to the end of the tube, the thumb is then placed over it. This end is then inverted into a vessel of mercury. The thumb is then removed. You will observe that mercury drops, leaving a space at the top. The space is called the Torricellian vacuum. The height AB is the column of mercury supported by the pressure of the atmosphere on the free surface of the mercury in the vessel. This is usually 76cm of mercury (fig. 16.8).



**Fig. 16.8: Simple Mercury Barometer**



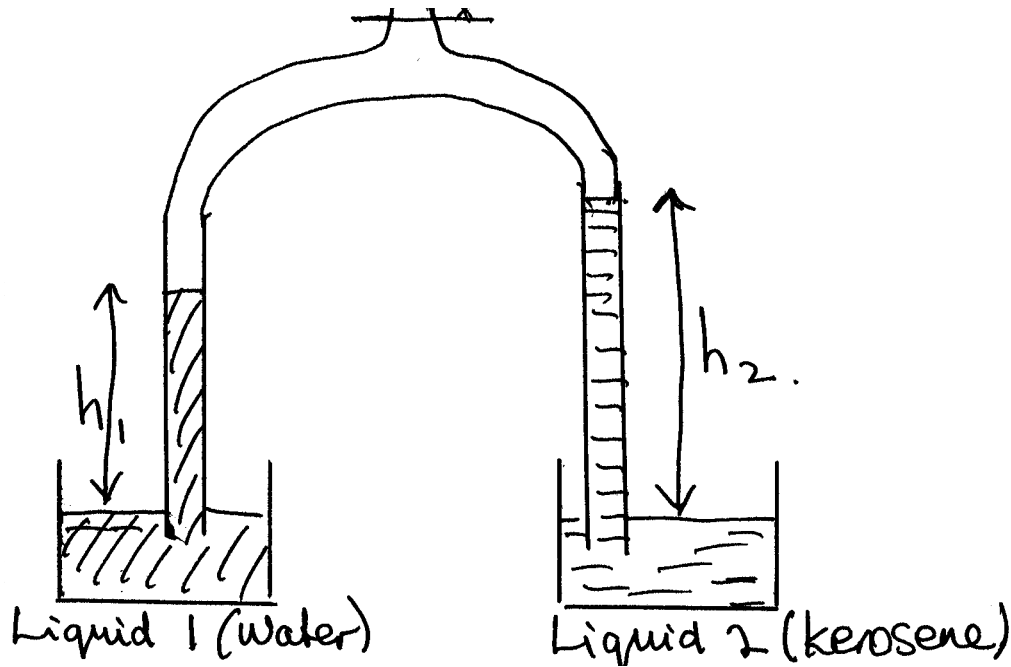
**Fig. 16.9: Fortin Barometer**

Most laboratories now have the Fortin barometers placed there to measure the atmospheric pressure. A Fortin barometer is similar in

structure with the simple barometer. It has a fixed scale from which the barometric height of the mercury column can be read easily.

### 3.6 The Hare's Apparatus

The Hare's apparatus is used to determine the relative densities of liquids through the use of pressure method. The Hare's apparatus is as shown in fig. 16.10



The pressure of the water =  $h_1\rho_1g$   
 While that of the liquid =  $h_2\rho_2g$

Since the pressures are the same we can then conclude that

$$h_1\rho_1g = h_2\rho_2g$$

$$\therefore \frac{\rho_2}{\rho_1} = \frac{h_1}{h_2} = \text{Relative density of the liquid} \dots\dots\dots (16.8)$$

### 4.0 CONCLUSION

Pressure is the force exerted by matter per unit area. Solids and fluids (liquids and gases) do exerted pressure. The unit of pressure is  $\text{Nm}^{-2}$  or Pascal.

Pressure transmitted in fluids obeys Pascal's Principle, which states that pressure applied at any point to a fluid in a closed vessel is transmitted equally to every other point in the fluid. This principle is applied in machines such as the hydraulic press, hydraulic jack and hydraulic brakes. The pressure due to a column of fluid is the product of the depth of the liquid, its density and acceleration due to gravity ( $P = h\rho g$ ). Manometer and the barometer are used in measuring pressures in the laboratory. Hare's apparatus is used to measure the relative density of a liquid by the use of pressure method.

## 5.0 SUMMARY

In this unit you have learnt that:

- The pressure on a surface is the force per unit area on that surface;
- The unit of pressure is Newton per meter square which is the Pascal;
- The pressure in fluids could be expressed as  $P = h\rho g$  – the product of the height of the liquid column, its density and acceleration due to gravity;
- Pressure can be transmitted through liquids following the Pascal's Principle;
- The hydraulic press, hydraulic jacks or brakes are based on Pascal's principles of transmission of pressure in liquids;
- Pressure can be measured using the manometer or the barometer ; and
- Relative density of a liquid can be measured using the pressure method as described in the use of Hare's apparatus.

### ANSWER TO SELF ASSESSMENT EXERCISE 1

The surface areas of the cube are the same

$$\therefore \text{Surface area of each face} = \frac{2}{100}m \times \frac{2}{100}m = 4 \times 10^{-4}m^2$$

$$\text{Weight of the cube} = 300N$$

$$\begin{aligned} \therefore \text{PRESSURE} &= \frac{\text{FORCE}}{\text{AREA}} \\ &= \frac{300N}{4 \times 10^{-4}m^2} \\ &= \frac{300}{4} \times 10^4 \frac{N}{m^2} \\ &= 7.5 \times 10^5 Pa \end{aligned}$$

## ANSWER TO SELF ASSESSMENT EXERCISE 2

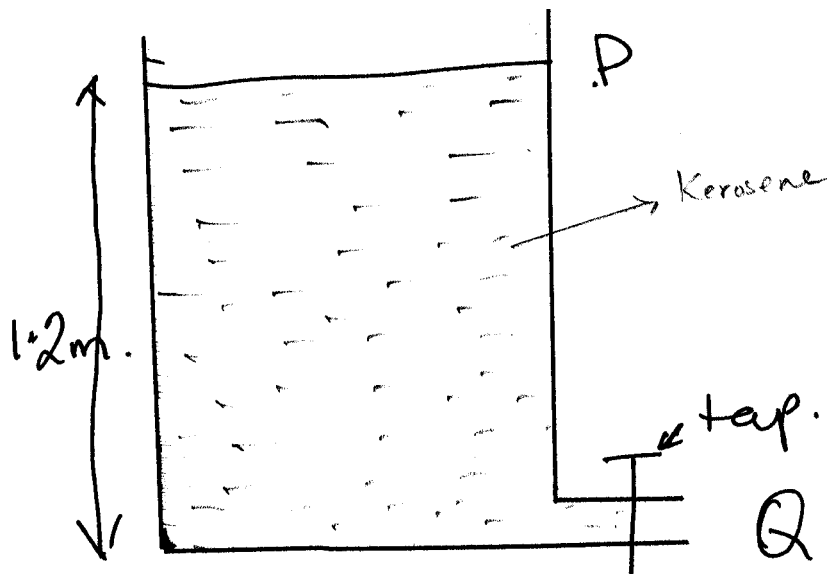


Fig. 16.11

$$\begin{aligned}
 \text{Pressure at Q} &= h\rho g \\
 &= 1.2\text{m} \times 800 \frac{\text{kg}}{\text{m}^3} \times 10.0 \frac{\text{m}}{\text{s}^2} \\
 &= 1.2\text{m} \times 800 \times 10 \frac{\text{kg}}{\text{m}^2} \cdot \frac{\text{m}}{\text{s}^2} \\
 &= 1.2\text{m} \times 800 \times 10 \frac{\text{N}}{\text{m}^2} \\
 &= 9600\text{Nm}^{-2} \\
 P &= 9600\text{Pa}
 \end{aligned}$$

## ANSWER TO SELF ASSESSMENT EXERCISE 3

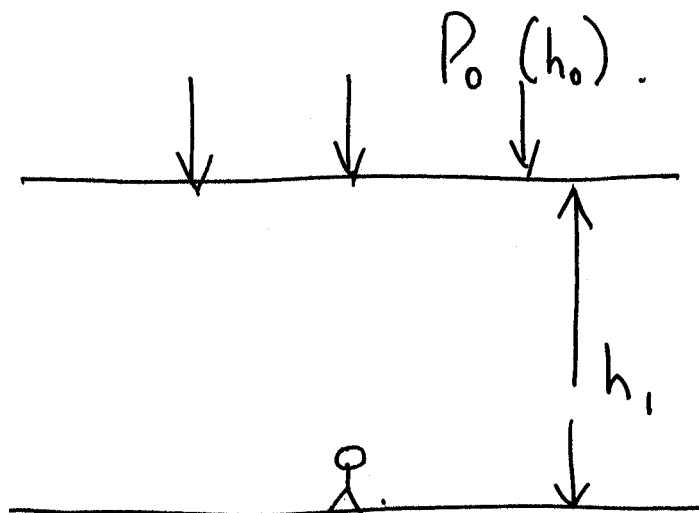


Fig. 16.12

Pressure due to the sea water

$$P_1 = h_1 \rho_1 g$$

$$P_1 \propto h_1 = 10\text{m sea water}$$

We need to convert this to that of mercury

We cannot say that total pressure is 760mm of Hg + 10m of sea water

The conversion equation is

$$h_1 \rho_1 g = h_2 \rho_2 g$$

Where,  $h_1 = 10\text{m of sea water}$

$$\rho_1 = \text{density of sea water} = 14050\text{kgm}^{-3}$$

$h_2 = \text{height of mercury}$

$$\rho_2 = \text{density of mercury} = 13600\text{kgm}^{-3} \times g$$

$$\therefore 10\text{m} \times 1050\text{kgm}^{-3} \times g = h_2 \times 13600\text{kgm}^{-3}$$

$$\therefore h_2 = \frac{10\text{m} \times 1050 \frac{\text{kg}}{\text{m}^3}}{13600 \frac{\text{kg}}{\text{m}^3}}$$

$$\begin{aligned} h_2 &= \frac{10\text{m} \times 1050}{13600} \\ &= 0.7721\text{m} \\ &= 772.1\text{mmHg} \end{aligned}$$

But pressure due to atmosphere = 750mmHg

$$\therefore \text{Total pressure} = (772.1 + 750) \text{mmHg} = 1522.1\text{mmHg}$$

(b) To express this  $\text{Nm}^{-2}$

We use  $p = h\rho g$

$$\begin{aligned} &= \frac{1522.1}{1000} \text{m} \times 13600 \frac{\text{kg}}{\text{m}^3} \times 10 \frac{\text{m}}{\text{s}^2} \\ &= 2.07 \times 10^5 \text{Nm}^{-2} \end{aligned}$$

#### ANSWER TO SELF ASSESSMENT EXERCISE 4

From,

$$\frac{F}{f} = \frac{A}{a}$$

$$\begin{aligned} \therefore F &= \frac{A}{a} \times f = \frac{0.1\text{m}^2}{0.01\text{m}^2} \times 150\text{N} \\ &= 1500\text{N} \end{aligned}$$

$$\therefore F: f = 1500\text{N}: 150\text{N} = 10:1$$

$$\text{i.e } F = 10f$$

The hydraulic press is a simple machine in which when work is done by the effort  $f$  by moving through distance  $h$ , while the load moves through a distance  $H$  (fig. 3.8). In this case, the efficiency of the hydraulic press  $E$  is defined as

## 6.0 TUTOR-MARKED ASSIGNMENT

1. A rectangular block of glass 12cm by 6cm by 2cm is placed on a horizontal surface so as to exert the least pressure on the surface. If the density of glass is  $2500\text{kgm}^{-3}$ , what will this least pressure be?
2. A bubble of air having a volume of  $0.35\text{cm}^3$  is at the bottom of a lake 51m deep. Determine its volume when it rises to the surface? (The atmospheric pressure is 750mmHg).
3. A hydraulic press where the area of the small piston is  $0.001\text{m}^2$  while the area of the large piston is  $0.1\text{m}^2$ . Calculate the weight of the load that can be lifted by the large piston when an effort of 80N is applied to the small piston.
4. Describe how you construct a simple mercury barometer.

## 7.0 REFERENCES/FURTHER READING

- Awe, O. and Okunola, O.O. (1986). *Comprehensive Certificate Physics*, Ibadan: University Press.
- Ference, M. (Jnr.), Lemon, H.B. and Stephenson, RJ (1970). *Analytical Experimental Physics*, Chicago: The University of Chicago Press.
- Feynman, R.P., Leighton, R.B. and Sands, M (1971). *The Feynman Lectures on Physics*, California: Addison-Wesley Publishing Company Limited.
- Flowers, B.H. and Mendoza, E (1970). *Properties of Matter*, London: John Wiley and Sons Limited.
- Noaks, M.A. (1963). *New Intermediate Physics*, Canada: Macmillan and company Limited.



Soars, F.W., Zemansky, M.W. and Young, H.D. (1980). *College Physics*. London: Addison-Wesley Publishing Company.

Tyler, F. (1966). *Heat and Thermodynamics*. London: Edwards Arnold Publisher Limited.

Wilkinson, J. (1983). *Essentials of Physics*, Australia: Macmillan Education Publishers.

Zemansky, M.W. (1968). *Heat and Thermodynamics*. New York: McGraw-Hill Book Company.

## UNIT 2      ELEMENTS OF HYDRODYNAMICS

### CONTENTS

- 1.0 Introduction
- 2.0 Objectives
- 3.0 Main Content
  - 3.1 Concept of Streamlines
  - 3.2 Streamlines and Velocity
  - 3.3 Pressure and Velocity
    - 3.3.1 The Change in Kinetic Energy of fluid
    - 3.3.2 The Change in Potential Energy of the Fluid
    - 3.3.3 Bernoulli's Principle
  - 3.4 Applications of Bernoulli's Principle
    - 3.4.1 At the Railway Station
    - 3.4.2 Filter pump (Venturi Pump)
    - 3.4.3 Aerofoil Lift
    - 3.4.4 Flow of Liquid from a Wide Tank
- 4.0 Conclusion
- 5.0 Summary
- 6.0 Tutor-Marked Assignment
- 7.0 References/Further Reading

### 1.0 INTRODUCTION

The past three units have been devoted to the properties of fluid at rest. In these units, you learnt about density, buoyancy and pressure due to fluids at rest. Now we focus our attention to the properties of fluids when they are in motion. Such a study is what is described as hydrodynamics. **Hydrodynamics is the study of fluids in motion. Have you ever wondered about how such a huge object like the plane can lift itself into space and carry its passengers safely to their destination/ have you ever compared the small bird's motion in space with that of the areoplane?**

The ability of both the bird and the aeroplane to fly is dependent on the knowledge of hydrodynamics especially the Bernoulli's Principle. So if you are interested in answering the above questions you will find this unit very interesting.

There was a time people had the idea that the railway engine has some magnet around it which it is capable of attracting human beings to it. Do you think this is true? With your knowledge of Bernoulli's Principle from this unit you will be able to accept or refute the idea.

Thus, in this unit we shall discuss about streamlines and the pressure and how they affect the velocity of a flowing fluid, Bernoulli's principle and its applications shall also be discussed.

## 2.0 OBJECTIVES

At the end of this unit, you should be able:

- explain the term streamlines
- relate streamlines with the velocity of a fluid in motion
- define the work done per unit volume on a fluid in terms of the pressure difference at two positions
- relate the work done per unit volume with the kinetic energy per unit volume
- state Bernoulli's Principle of fluids in motion
- apply Bernoulli's Principle in nature.

## 3.0 MAIN CONTENT

### 3.1 Concept of Streamlines

The knowledge of the laws governing fluid flow is very important in the distribution of water, gas and oil in pipelines and for efficient transmission of energy in hydraulic machines.

The rate of flow of a fluid is measured by the volume of the fluid that passes through a cross-section per unit time.

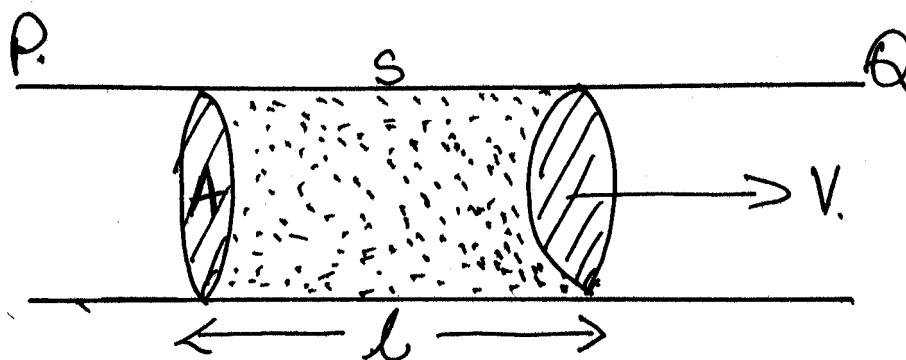


Fig. 17.1

Consider a pipe PQ with some liquid flowing through it (see fig. 17.1). Consider a section S of cross-sectional area A and length (l) moving with an average velocity V. The volume of the liquid V moving per second is given as:

$$\frac{V}{t} = \frac{Al}{t} \dots\dots\dots (17.1)$$

Since, volume = area x length

But its average velocity =  $\frac{\text{length}}{\text{time}}$

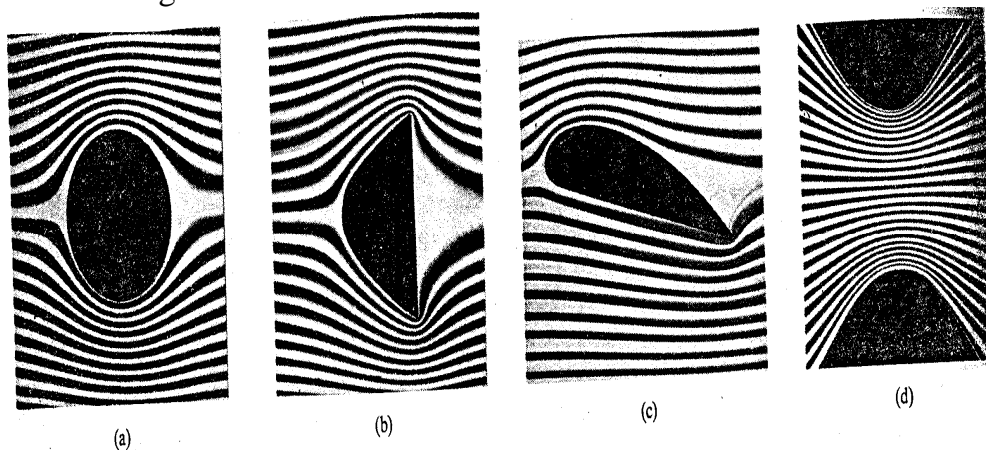
∴ length (l) = velocity (v) x time(t)

$$\therefore \frac{V}{t} = \frac{Al}{t} = \frac{A v t}{t} = Av$$

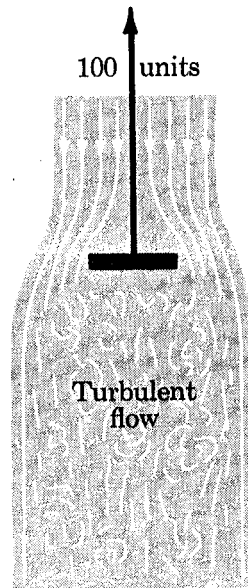
That is the volume per time is equal to the area times the average velocity of the fluid. When the fluid is at rest, the pressure is the same at all points at the same elevation of the container. But once in motion, the pressure is no longer the same. There is a fall in pressure as the fluid flows. Any detailed description of fluids in motion is somewhat complicated. However, we shall talk about some elements in the study of hydrodynamics such as streamlines. But first it is vital to know about a streamline.

The flow of fluids can be described as being a steady flow or a stationary flow and turbulent.

When it is a steady flow we have streamlines as shown in fig. 17.2. The absence of streamlines makes the flow turbulent. The turbulent flow is shown in fig. 17.3.

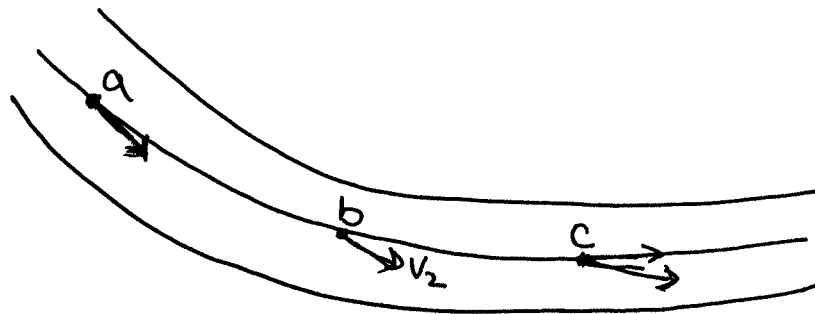


**Fig. 17.2: Streamline Flow around Obstacles of Various Shapes**



**Fig. 17.3: Turbulent Flow**

Consider a fluid flowing through a pipe as in fig. 17.4



**Fig. 17.4**

If at position a, a particle of the fluid has a velocity  $v_1$ , at b, its velocity is  $v_2$  and at c, its velocity is  $v_3$ .

If after some time, the velocity of whatever fluid particle happens to be at a is still  $v_1$ , that at b is  $v_2$  and that at c is  $v_3$ , then the motion is said to be steady or stationary.

Now, the path followed by a fluid particle in a steady flow as it travels the length of the pipe is what is described as a streamline. Consequently the flow of the fluid of the pipe will be made up of streamlines (fig. 17.5).

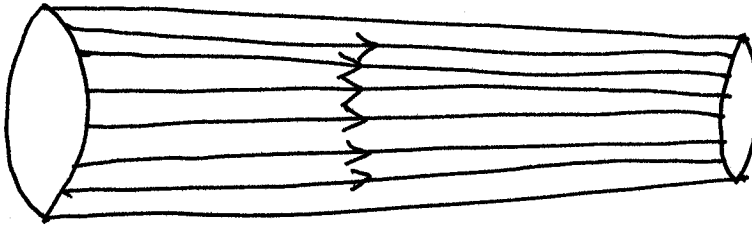


Fig. 17.5: Streamlines

### SELF ASSESSMENT EXERCISE 1

What does it mean by a steady flow in hydrodynamics? With the aid of diagrams explain what is meant by streamlines.

### 3.2 Streamlines and Velocity

In this section, we want to examine the streamline flow of a fluid and the variation of its velocities as the fluid moves from a large cross-sectional area to a smaller cross-sectional area. In other words, how do the streamlines behave when there is constriction in the pipe?

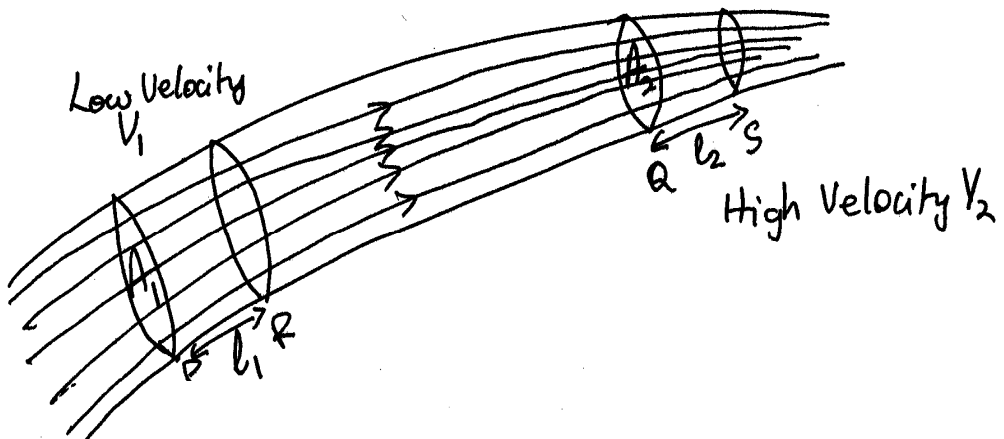


Fig. 17.6

Consider a pipe XY as shown in fig. 3.6 such that the end of X is wider than that of Y. Consider the bulk of water flowing through from X to Y. Consider the bulk of water flowing through the wider passage PR to a narrower passage QS as shown in fig. 17.6

Volume of water per second through PR  $\frac{V}{t} = A_1 v_1$

While the volume of water per second through QS  $\frac{V}{t} = A_2 v_2$

Because water is incompressible the volume of water moving per second through PR must be the same through QS

$$\therefore A_1 v_1 = A_2 v_2 \dots\dots\dots (17.2)$$

Since  $A_1$  is greater than  $A_2$ , for the equation to balance, then  $v_1$  is less  $v_2$ . That is, velocity ( $v_1$ ) between P and R is low while that between Q and S ( $v_2$ ) is high. It is observed that the water flows slowly at the wider passage while it flows faster through the narrow openings or constrictions. In simple words, the larger is the area of cross-section, smaller will be the velocity of liquid flow and vice versa.

That is, changes in pressure does not cause in fluid density at various parts. For steady flow therefore, the volume of the fluid per second must be constant at all points.

The velocity of the fluid does not change at a given point, as time elapses, but it may be different at different places. When the flow is steady, the paths actually followed by the moving particles of the fluid are called streamlines. The streamlines of the flow represent the directions of the velocities of the particles of the fluid.

A flow is uniform or laminar. Once more, it should be emphasized that it is assumed that the liquid is incompressible.

If the water moves from PQ to RS the volume of the liquid between P and R is equal to the volume between Q and S.

$$\therefore A_1 \ell_1 = A_2 \ell_2 \dots\dots\dots (17.3)$$

where,  $\ell_1 = PR$  and  $\ell_2 = QS$

On rearranging the terms, we get

$$\therefore \frac{A_1}{A_2} = \frac{\ell_1}{\ell_2} \dots\dots\dots (17.4)$$

Since  $A_1$  is greater than  $A_2$ , therefore

Diving both side by  $t$   $\ell_1 > \ell_2$

$$\therefore \frac{\ell_2}{t} > \frac{\ell_1}{t}$$

$$\therefore v_2 > v_1$$

Since velocity is displacement per time.

Consequently the velocity of the liquid at the narrow part (Y) of the tube (constriction) where the streamlines are closer together than that at the wider part X where the streamlines are further apart.

You can see an example of this in our everyday life. A slow running tap can be made to run fast by applying a finger over the tap of narrow its exit i.e. cause a constriction.

This increase in velocity implies the presence of acceleration. Of this force to be caused by the fluid surrounding a particular element of the fluid the presence must be different in different regions.

If the pressure were to be the same everywhere, the net force on any fluid element would be zero. So, when the cross-section of a flow tube varies, the pressure must vary along the tube even when there is no difference in elevation.

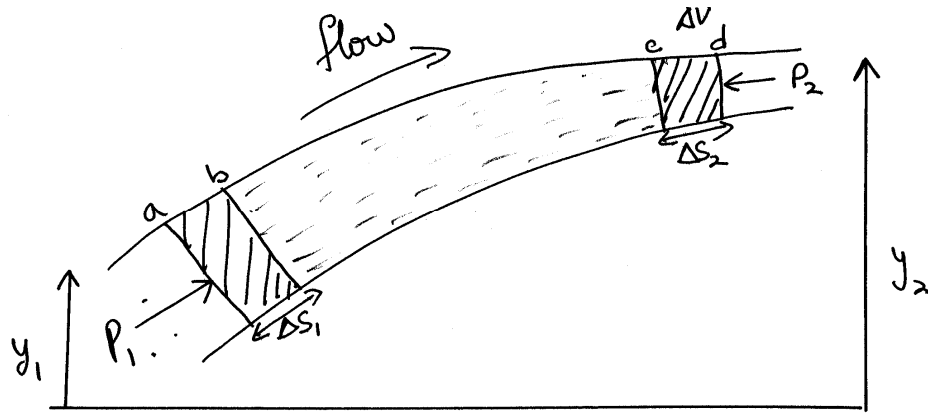
## **SELF ASSESSMENT EXERCISE 2**

Given a pipe AB such that the end A is wider than end B. Show that when water flows through the pipe the velocity of the water at A is less than that velocity at the end B. State your assumptions.

### **3.3 Pressure and Velocity**

Pressure and velocity form another set of elements of hydrodynamics. It was the scientist Daniel Bernoulli (1740) who observed and obtained the relationship between pressure and velocity at different parts of a moving incompressible fluid. Bernoulli's equation is a general expression that relates the pressure difference between two points in a flow tube to both velocity changes and elevation changes. In discussing Bernoulli's equation it is assumed that viscosity (fluid friction) is negligibly small, then there is no frictional force to overcome.





**Fig. 17.7**

Consider a fluid at some initial time  $t$  lying between two cross-sections  $a$  and  $c$ . At a time interval  $\Delta t$ , the fluid moves from  $a$  to  $b$  through a distance of  $\Delta s_1$  as shown in fig. 17.7.

$$\therefore \Delta s_1 = v_1 \Delta t \dots\dots\dots (17.5)$$

Where,  $v_1$  is the speed at one end of the tube.

Similarly, at the same time interval  $\Delta t$ , the fluid moves from  $c$  to  $d$  through a distance of  $\Delta s_2$ .

$$\Delta s_2 = v_2 \Delta t \dots\dots\dots (17.6)$$

- Where,  $v_2$  is the velocity of the fluid at the other end of the tube. Let  $A_1$  be the cross-sectional area at  $a$  and  $A_2$  is the cross-sectional area at  $c$ .

$$\text{Change in volume of the fluid} = A_1 \Delta s_1 = A_2 \Delta s_2 \dots\dots\dots (17.7)$$

Now, we will determine the work done during this time interval  $\Delta t$  by using the relation,

$$\frac{\text{FORCE}(F)}{\text{AREA}(A)} = \text{PRESSURE (P)}$$

We can rewritten the above expression as you know that

$$F = PA \dots\dots\dots (17.8)$$

$$\therefore \text{Work done} = \text{force} \times \text{distance}$$

But the fore at  $a = P_1 A_1$  Similarly, the force at  $c = P_2 A_2$

Where  $P_1$  and  $P_2$  are the pressures at the two ends of the flow tube.

$$\text{Work done at end a} = F_1 \Delta s_1 = P_1 A_1 \Delta s_1 \dots\dots\dots (17.9)$$

$$\text{Similarly, work done at end c} = F_2 \Delta s_2 = P_2 A_2 \Delta s_2 \dots\dots\dots (17.10)$$

Using the Eqs. (17.9) and (17.10), the

$$= P_1 A_1 \Delta s_1 - P_2 A_2 \Delta s_2$$

But as you know from section 3.2 or from Eq. (17.7) that

$$A_1 \Delta s_1 = A_2 \Delta s_2 = \text{change in volume}$$

$$\therefore \text{net work done} = (P_1 - P_2) \times \text{change in volume}$$

$$\therefore P_1 - P_2 = \frac{\text{NETWORK DONE}}{\text{CHANGE IN VOLUME}}$$

$$\text{Change In Pressure} = \frac{\text{Network Done}}{\text{Change in Volume}} \dots\dots\dots (17.11)$$

### 3.3.1 The Change in Kinetic Energy of Kind

We are still considering fig. 17.7 for this section.

At the initial stage, the initial kinetic energy of the fluid ( $KE_1$ ) is given as

$$\begin{aligned} KE_1 &= \frac{1}{2} \times \text{mass of fluid} \times (\text{velocity})^2 \\ &= \frac{1}{2} m_1 v_1^2 \dots\dots\dots (17.12) \end{aligned}$$

From the definition of density, the mass can be expressed as

$$m_1 = \text{density} \times \text{volume} = P A_1 \Delta s_1$$

Therefore, the expression for kinetic energy is as

$$\therefore KE_1 = \frac{1}{2} P (A_1 \Delta s_1) \times v_1^2 \dots\dots\dots (17.13)$$

Where, the symbols  $P$  = density of fluid  
 $v_1$  = velocity of fluid at ab  
 $A_1$  = area  
 $\Delta s_1$  = displacement

At the end of the time interval the final kinetic energy is where is given as

$$\begin{aligned}
 KE_2 &= \frac{1}{2} m_2 v_2^2 = \frac{1}{2} P (A_2 \Delta s_2) \times v_2^2 \\
 KE_2 &= \frac{1}{2} P (A_2 \Delta s_2) \times v_2^2 \dots\dots\dots (17.14)
 \end{aligned}$$

But  $A_2 \Delta s_2 =$  change in volume. These expressions of kinetic energies can be interpreted in terms of change in volume as

$$KE_1 = \frac{1}{2} P \times \text{change in volume} \times v_1^2 \dots\dots\dots (17.15)$$

$$\text{and } KE_2 = \frac{1}{2} P \times \text{change in volume} \times v_2^2 \dots\dots\dots (17.16)$$

The net change in kinetic energy

$$\begin{aligned}
 \Delta KE &= KE_2 - KE_1 \\
 &= \frac{1}{2} P \times \text{change in volume} \times (v_2^2 - v_1^2) \dots\dots\dots (17.17)
 \end{aligned}$$

$$\therefore \frac{\text{Change in KE}}{\text{Change in volume}} = \frac{1}{2} P (v_2^2 - v_1^2) \dots\dots\dots (17.18)$$

**3.3.2 The Change in Potential Energy of the Fluid**

To determine the change in potential energy of the fluid, refer to fig. 17.7. The initial potential energy of the fluid at a, at height  $y_1$  is given as  $PE_1$

$$\begin{aligned}
 PE_1 &= M_1 g y_1 \\
 \text{where, } M_1 &= P A_1 \Delta s_1 \\
 \therefore PE_1 &= P A_1 \Delta s_1 y_1 g \\
 PE_1 &= P y_1 \times (\text{change in volume}) \times g \dots\dots\dots (17.19)
 \end{aligned}$$

Similarly, at the other end of the time interval  $\Delta t$ , the potential energy at d, height  $y_2$  is given as  $PE_2$  where,

$$\begin{aligned}
 PE_2 &= M_2 g y_2 \\
 \text{where, } M_2 &= P A_2 \Delta s_2 \\
 \therefore PE_2 &= P A_2 \Delta s_2 y_2 g \\
 PE_2 &= P y_2 \times (\text{change in volume}) \times g \dots\dots\dots (17.20)
 \end{aligned}$$

The change in potential energy  $\Delta U$  is given as

$$\Delta U = P g (y_2 - y_1) \times \text{change in volume}$$

$$\frac{\text{Change in PE}}{\text{Change in volume}} = P g (y_2 - y_1) \dots\dots\dots (17.21)$$

Since the work done by the pressure difference per unit volume of a fluid flowing along a pipe is equal to the kinetic energy per unit volume plus the gain in potential energy per unit volume, we can state that:

$$\frac{W}{\Delta V} = \frac{\Delta KE}{\Delta V} + \frac{\Delta U}{\Delta V} \dots\dots\dots (17.22)$$

where,  $\Delta V$  – change in volume of fluid

The principle of conservation of energy may also be used to arrive at this conclusion.

Consequently,

$$P_1 - P_1 = \frac{1}{2} P (v_2^2 - v_1^2) + P g (y_2 - y_1) \dots\dots\dots (17.23)$$

On rearranging the terms in Eq. (17.23), we get

$$\therefore P_1 - P_1 = \frac{1}{2} P v_2^2 - P v_1^2 + P g y_2 - P g y_1$$

$$\therefore P_1 + \frac{1}{2} P v_1^2 + P g y_1 = P_2 + \frac{1}{2} P v_2^2 + P g y_2$$

Generally, we can write that

$$P + \frac{1}{2} P v^2 + P g y = \text{CONSTANT} \dots\dots\dots (17.24)$$

Consequently, for streamline motion of an incompressible non-viscous fluid,

**“The sum of the pressure at any point plus the kinetic energy per unit volume plus the potential energy per unit volume is always a constant”.**

The above statement is what describes Bernoulli’s principle.

### 3.3.3 Bernoulli’s Principle

In the last section (3.3.2) we arrived at the Eq. (17.24) that

$$P + \frac{1}{2} P v^2 + P g y = \text{CONSTANT}$$

This is what we refer to as Bernoulli's equation from which we derived the Bernoulli's principle.

**Bernoulli's principle states that: In a streamline flow of an ideal fluid, the sum of the pressure energy per unit volume of the kinetic energy per unit volume are potential energy per unit volume is always constant at all cross-section of the liquid.**

Dividing the Bernoulli's equation (17.24) by  $P_g$  we would obtain this expression,

$$\frac{P}{P_g} + \frac{v^2}{2g} + y = \text{CONSTANT} \dots\dots\dots (17.25)$$

Each of the above terms in the equation has the dimensions of length. Can you check this? Try to do this before you proceed further. When we were discussing pressure, we talked about pressure head  $h$  in liquids, fluids generally.

- $\frac{P}{P_g}$  represents the pressure head
- $\frac{v^2}{2g}$  represents the velocity head
- $y$  represents the velocity head

Remember that Bernoulli's principle is correct rigorously for incompressible, non-viscous liquids; it is often applied to ordinary liquids with sufficient accuracy for engineering proposes.

Bernoulli's principle shows that at some points in a moving fluid where the potential energy change is small or zero, **as in the flow through horizontal pipe, the pressure is low where the velocity is high.** Conversely, **the pressure is high where the velocity is low.** **This principle has wide applications in life.**

### SELF ASSESSMENT EXERCISE 3

The area of cross-section  $A_1$  of X is  $4\text{cm}^2$ , the area of Y is  $1\text{cm}^2$  and the water flows past each section in laminar flow at the rate of  $400\text{cm}^3$ . Calculate the pressure difference and the pressure head. Consider fig. 17.8 below.

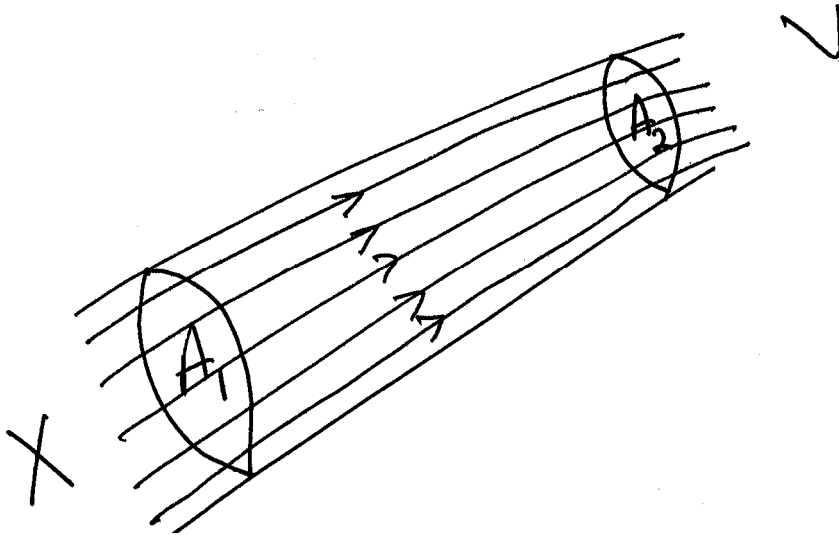


Fig. 17.8

### 3.4 Applications of Bernoulli's Principle

After studying about the Bernoulli's principle in detail, now in this section we shall try to examine the various applications of the Bernoulli's principle in terms of:

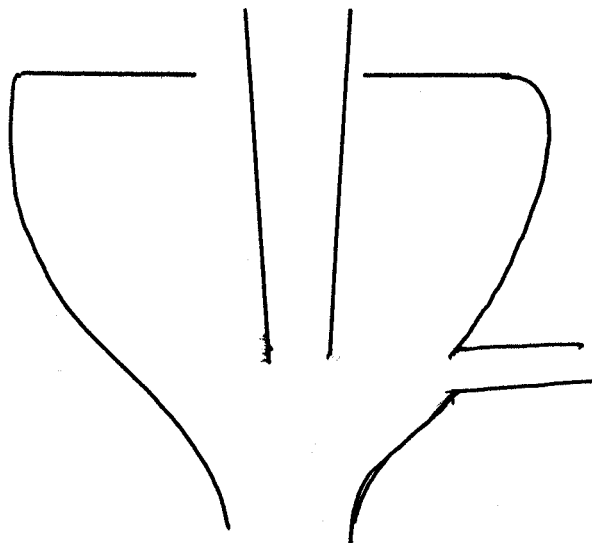
- The suction effect of a person at the railway station;
- The venture (filter) pump sometimes called suction pump;
- Aerofoil lift in areoplanes; and
- Flow of liquids from wide tanks.

#### 3.4.1 At the Railway Station

A person standing close to the platform at a railway station experiences a suction effect when a fast train passes by.

The fast moving air between the person and the train produces decrease in pressure and the excess air pressure on the other side of the person pushes him or her towards the train.

### 3.4.2 Filter Pump (Venturi Pump)

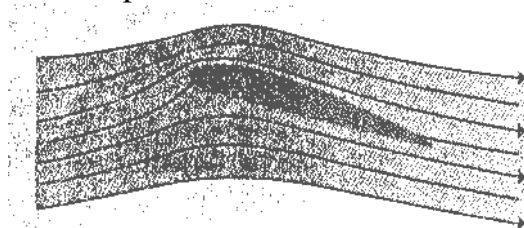


**Fig 17.8**

The filter pump is used in most laboratories for fast effective filtration of precipitates in solutions. The pump has a narrow section in the middle so that a jet of water from the tap flows fast here see figure 17.8. This causes a drop in pressure near it and air therefore flows in from the side tube to which a vessel is connected. The air and water together are expelled through the bottom of the filter pump.

### 3.4.3 Aerofoil Lift

The curved shape of an aerofoil or the wings of the areoplanes creates a fast flow of over its top surface than the lower surface (fig. 17.9).



**Fig. 17.9: Flow Lines around an Airfoil**

This is shown by the closeness of the streamlines above the aerofoil compared with those below. From Bernoulli's principle, the pressure of the air below is greater than that above. This produces the lift on the aerofoil.

### 3.4.4 Flow of Liquid from a Wide Tank

Here we want to consider the flow of water a wide tank as shown in fig.17.10

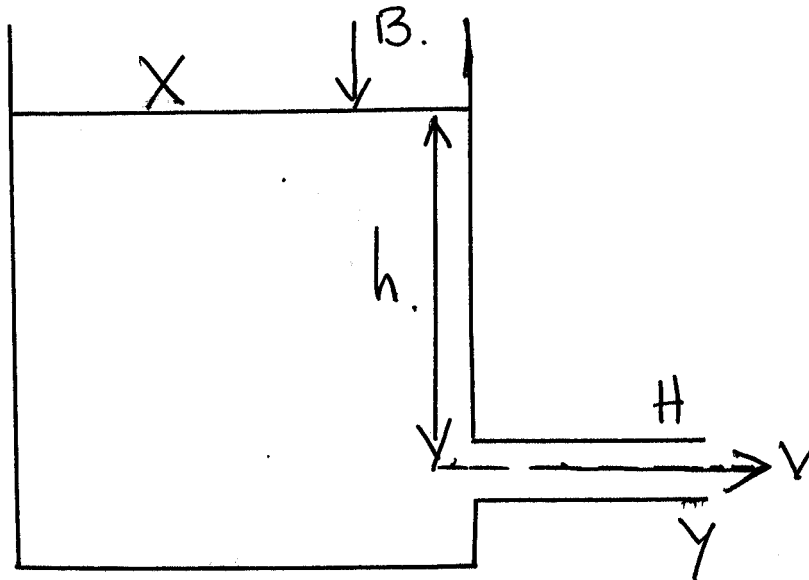


Fig. 17.10

The liquid flows out of the tank through a hole  $H$  at the bottom of the wide tank. We are making the following assumptions,

- The viscosity is negligible
- Streamline flow at a small distance from the hole (an approximation)

We shall now apply Bernoulli's principle. At the top of the tank  $X$ , the pressure is atmospheric ( $B$ ). The height  $h$ , the water pressure head from  $X$  to the hole  $H$ . The kinetic energy of the flow is negligible if the tank is wide so that the level falls slowly.

At the bottom  $Y$ , near  $H$ , the pressure is also atmospheric ( $B$ ). The height above  $H$  is zero. The kinetic energy of flow is  $\frac{1}{2}pv^2$  where  $p$  is density of the liquid and  $v$  is the velocity of emergency of the liquid.

From Bernoulli's principle,

$$\begin{aligned}
 B + phg &= B + \frac{1}{2}pv^2 \\
 \therefore phg &= \frac{1}{2}pv^2 \\
 \therefore &= 2gh \\
 \therefore v &= \sqrt{2gh} \dots\dots\dots (17.26)
 \end{aligned}$$

Thus the velocity of the emerging liquid is the same as that which would be obtained if it fell through a height  $h$ .



This is Evangelista Torricelli's theorem (1641)

$$v = \sqrt{2gh}$$

In practice,  $v$  is less than  $v = \sqrt{2gh}$  because of the viscous forces and the lack of streamline flow.

#### 4.0 CONCLUSION

Streamline are some elements of hydrodynamics in fluids as they flow in pipes or over obstacles. When fluids flow through pipes that are of different diameters there are changes in the streamlines and the velocities of the fluid at different points. Where the diameter is large the streamlines are spaced and the velocity is low. But when the diameter is small that is, where there is constriction, the streamlines are close to each other and the velocity of the fluid is increased. The Bernoulli's principle is concerned with the pressure difference in the flow of fluid in association with the kinetic energy per unit volume and the potential energy per unit volume of the flow of the fluid. The principle is similar to the conservation of energy. Bernoulli's principle has been used to explain some natural phenomena.

#### 5.0 SUMMARY

In this unit, you learnt about the following:

- Streamline and how they affect the velocity of flow of a liquid;
- The velocity of the fluid is increased where there is a constriction in the streamlines;
- The velocity of the fluid is decreased where they seem to diverge;
- Bernoulli's principle which states that of streamline motion of an incompressible non-viscous fluid, **the sum of the pressure energy per unit volume, kinetic energy per unit volume and the potential energy per unit volume is always constant at all cross-section of liquid.**

$$P + \frac{1}{2} \rho v^2 + \rho gy = \text{CONSTANT}$$

- Bernoulli's principle could be used to explain certain phenomena in life such as:
  - (a) The attraction between an object and a moving train
  - (b) The filter pump
  - (c) The aerofoil lift
  - (d) The flow of liquids from a sprout at the bottom of a tank.

**ANSWER TO SELF ASSESSMENT EXERCISE 1**

In steady flow, the path followed by a fluid particle is what is described as streamline. Consequently, the flow of the fluid in the pipe will be made up of streamlines.

Note: For detail, you can refer to the text.

**ANSWER TO SELF ASSESSMENT EXERCISE 2**

SEE TEXT - Refer to the section 3.2 of the text.

**ANSWER TO SELF ASSESSMENT EXERCISE 3**

At X, speed  $v_1$  of water =  $\frac{\text{Volume}}{\text{second}} \times \frac{1}{\text{area}}$

From,  $\frac{\text{Volume}}{\text{second}} = \text{area} \times \text{speed}$

where, volume per second =  $400\text{cm}^3\text{s}^{-1}$  and area =  $4\text{cm}^2$

$$\begin{aligned} \therefore v_1 &= 400 \frac{\text{cm}^3}{\text{s}} \times \frac{1}{4\text{cm}^2} \\ &= 100\text{cm/s} = 1\text{ms}^{-1} \end{aligned}$$

Similarly, at Y, speed  $v_2$  of water =  $\frac{\text{Volume}}{\text{second}} \times \frac{1}{\text{area}}$

$$\begin{aligned} \therefore v_2 &= 400 \frac{\text{cm}^3}{\text{s}} \times \frac{1}{1\text{cm}^2} \\ &= 400\text{cm/s} = 4\text{ms}^{-1} \end{aligned}$$

From Bernoulli's principle,

$$P_1 - P_2 = \frac{1}{2} \rho (v_2^2 - v_1^2) + \rho g (y_2 - y_1)$$

Assuming there is no change in potential energy and density of water is  $1000\text{kgm}^{-3}$ .

$$\begin{aligned} \therefore P_1 - P_2 &= \text{Pressure difference} \\ &= \frac{1}{2} \rho (v_2^2 - v_1^2) \end{aligned}$$

$$\begin{aligned}
 &= \frac{1}{2} \times 1000 \frac{\text{kg}}{\text{m}^3} \times (4^2 - 1^2) \frac{\text{m}}{\text{s}^2} \\
 &= \frac{1}{2} \times 1000 \times (16 - 1) \frac{\text{N}}{\text{m}^2} \\
 &= \frac{1}{2} \times 1000 \times 16 \frac{\text{N}}{\text{m}^2}
 \end{aligned}$$

$$\text{Pressure difference} = 7.5 \times 10^3 \text{Nm}^{-2}$$

From  $P = h\rho g$

$$\therefore h = \frac{P}{\rho g} = \frac{7.5 \times 10^3}{1000 \times 10} \text{m} = 0.75 \text{m}$$

Pressure head = 0.75m of water.

## 6.0 TUTOR-MARKED ASSIGNMENT

1. A lawn sprinkler has 20 holes each of cross-sectional area  $2.0 \times 10^{-2} \text{cm}^2$  and is in connection to a hosepipe of cross-sectional area  $2.4 \text{cm}^2$ . If the speed of the water in the hosepipe is  $1.5 \text{ms}^{-1}$  estimate the speed of the water as it emerges from the holes.
2. A pipeline 0.2m in diameter, flowing full of water has a constriction of diameter 0.1m. If the velocity in the 0.2m portion is 2.0m/s find the velocity of the water in the constriction and the discharge rate in cubic metres per second.
3. Water enters a house through a pipe 2.0m in inside diameter at an absolute pressure of  $4 \times 10^5 \text{Pa}$ . The pipe leading to the second-floor bathroom 5m above is 1.0m in diameter. When the flow velocity at the inlet pipe is 4m/s, find the flow velocity and pressure in the bathroom.

## 7.0 REFERENCES/FURTHER READING

- Awe, O. and Okunola, O. O. (1986). *Comprehensive Certificate Physics*, Ibadan: University Press.
- Ference, M. (Jnr.), Lemon, H.B. and Stephenson, R. J. (1970). *Analytical Experimental Physics*, Chicago: The University of Chicago Press.
- Feynman, R. P., Leighton, R. B. and Sands, M. (1971). *The Feynman Lectures on Physics*, California: Addison – Wesley Publishing Company Limited.
- Flowers, B. H. and Mendoza, E. (1970). *Properties of Matter*, London: John Wiley and Sons Limited.
- Noaks, M. A. (1963). *New Intermediate Physics*, Canada: Macmillan and company Limited.
- Soars, F. W., Zemansky, M.W. and Young, H. D. (1980). *College Physics Addison – London: Wesley Publishing Company*.
- Tyler, F. (1966). *Heat and Thermodynamics*. London: Edwards Arnold Publisher Limited.
- Wilkinson, J. (1983). *Essentials of Physics*, Australia: Macmillan Education Publishers.
- Zemansky, M.W. (1968). *Heat and Thermodynamics*. New York: McGraw-Hill Book Company.

## UNIT 3 VISCOSITY OF FLUIDS

### CONTENTS

- 1.0 Introduction
- 2.0 Objectives
- 3.0 Main Content
  - 3.1 Concept of Viscosity
  - 3.2 Velocity Gradient in Moving Fluids
  - 3.3 Coefficient of Viscosity  $\eta$ 
    - 3.3.1 Variation of  $\eta$  with Temperature
  - 3.4 Poiseuille's Formula
    - 3.4.1 Measurement of  $\eta$  by Capillary Flow Method
  - 3.5 Stokes' Law and Terminal Velocity
    - 3.5.1 Measuring  $\eta$  by Falling Sphere
- 4.0 Conclusion
- 5.0 Summary
- 6.0 Tutor-Marked Assignment
- 7.0 References/Further Reading

### 1.0 INTRODUCTION

Suppose you are given three identical bottles containing water, engine oil and honey each. If you are then asked to transfer them into other containers, how would you compare the time it will take to empty the liquids?

You would observe that it takes the most time to empty the bottle of honey while that of water takes the least. What explanation can we provide for this observation? The explanation that readily comes to mind is that the rate of flow in each liquid. Each liquid flows with some difficulties. The difficulty to flow by a liquid is what is being referred to as the viscosity of a liquid or fluids in general. Viscosity therefore deals with friction in the flow of fluids. Viscosity is a property of fluids in motion. Sometimes, it is called fluid friction.

In this unit, we shall again examine the concept of viscosity as it affects fluids. We will also discuss about the Poiseuille's formula which helps us to determine Stoke's law and the concept of terminal velocity are also given in this unit.

## 2.0 OBJECTIVES

At the end of this unit, you should be able to:

- explain the concept of viscosity as applied to fluids
- define the coefficient of viscosity of fluids
- explain the rate of flow of liquids through pipes
- state Stoke's law
- explain the concept of terminal velocity.

## 3.0 MAIN CONTENT

### 3.1 Concept of Viscosity

Viscosity is the frictional force in fluids. Generally, viscosity in a liquid in a liquid is an attribute to the effect of the cohesive forces of the molecules relatively close together in a liquid. When liquids flow through pipes they have frictional force between their layers. The same thing happens when gases move or when objects move through air. However while the molecules of a liquid are very close to each other, those of gases are too far apart for their cohesion to be effective.

The viscosity of fluids affects the volume of the fluid flowing per second as the fluid flows in a pipe. Viscosity also affects the lubrication of moving parts in machines as in car engines. It is not easy to realize that when a liquid flows along a pipe, there are layers of the fluid moving with different velocities. The molecules seem to be moving fastest at the centre along the axis of the pipe. Whereas the velocity decreases as one move towards the wall of the pipe, the velocity tends to zero. The variation of such velocity is shown in fig. 18.1.

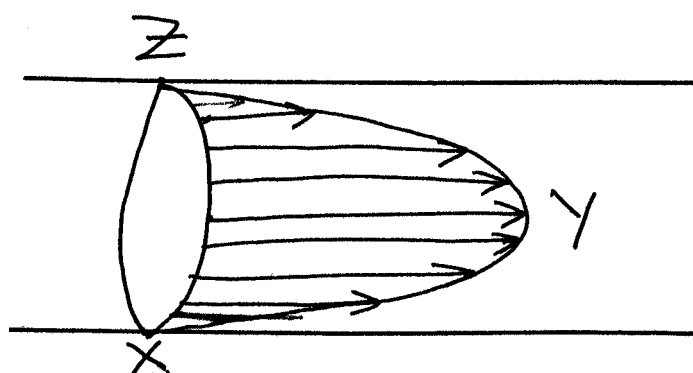


Fig. 18.1

The length of each line segment is proportional to the magnitude of the velocity. So you will observe that at Y the line segment is the longest so the velocity of the fluid is the maximum while at X and Z the line

segments are the smallest thus, the velocity of the liquid tends to zero there.

### 3.2 Velocity Gradient in Moving Fluids

Let us consider two adjoining layers of a liquid P and Q moving in a pipe, such that the two layers are  $r$  cm apart (fig. 18.2).

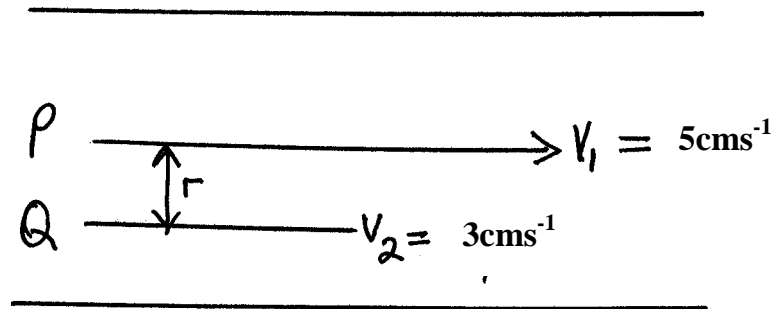


Fig. 18.2

If the velocity of the layer P is  $V_1 = 5\text{cm s}^{-1}$  and that of layer Q is  $V_2 = 3\text{cm s}^{-1}$  and they are  $r = 4\text{cm}$  apart, we shall define their average velocity gradient as

$$\text{Average velocity gradient} = \frac{V_1 - V_2}{r} = \frac{(5 - 3) \frac{\text{cm}}{\text{s}}}{4\text{cm}} = 2 \frac{\text{cm}}{\text{s}} \frac{1}{4\text{cm}} = 0.5\text{s}^{-1}$$

The average velocity gradient  $G$ , is therefore defined as the rate of change of velocity of the moving layers of the fluid per the change in distance between the moving layers

$$\therefore \text{average velocity gradient} = \frac{\Delta V}{\Delta r} = G$$

From calculus point of view, the limit of  $G$  as the change in  $r$  tends to zero is defined as

$$\text{Limit } G = \frac{dV}{dr} \dots\dots\dots (18.1)$$

$$\Delta \rightarrow 0$$

#### SELF ASSESSMENT EXERCISE 1

Explain the meaning of average velocity gradient as it affects the viscosity of a fluid in a pipe.

### 3.3 Coefficient of Viscosity $\eta$

As you have learnt about coefficient of friction in mechanics, here you will study the coefficient of viscosity of fluids. It is a property of fluids when they are in motion. You will recall, the idea about steady flow or non-turbulent flow of a fluid is also described as being uniform, orderly flow or laminar flow. Newton stated that under the condition of steady flow, the frictional force (F) between two layers moving fluid is proportional to:

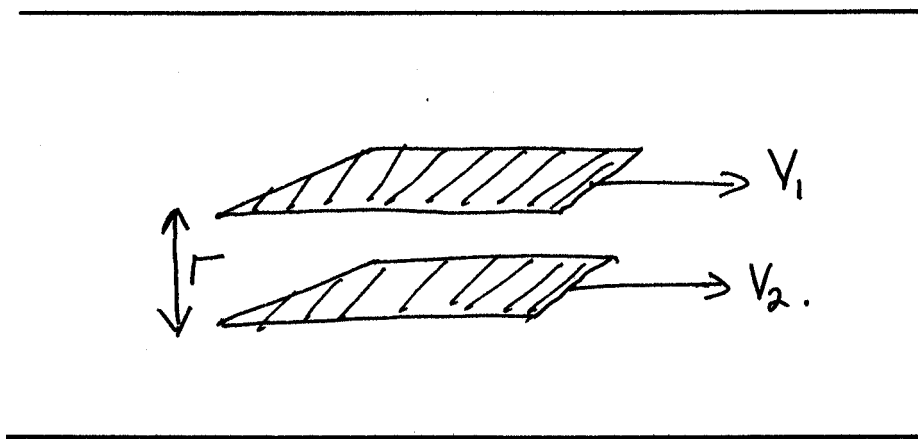
- its velocity gradient G and
- the area (A) parallel to the fluid flow of the liquid under consideration

Hence,  $F \propto AG$  ..... (18.2)

$\therefore F = \eta AG$  (where,  $\eta = \text{eta}$ , a Greek letter)

This direction of the force (F) is opposite to the direction of velocity. If  $A = 1, G = 1$ , then  $\eta = F$ .

Here  $\eta$  is a constant known as the coefficient of viscosity of the fluid.  **$\eta$  is defined as the frictional force required to maintain a unit velocity gradient between two layers each of unit area.** (See fig. 18.3).



**Fig. 18.3**

What do you think would be the unit and dimensions of  $\eta$  the coefficient of viscosity?

Let us discuss about them now. You remember that in friction between two surfaces, the coefficient of friction has no unit. Let us now derive the unit of the coefficient of viscosity in fluids. The unit of force (F) is



N(Newton) and the Unit of area (A) is m<sup>2</sup> (meter square). In section 3.2, you noted that the unit of velocity gradient (G) is s<sup>-1</sup>. Then, the

$$\therefore \text{unit of } \eta \text{ is } \frac{\text{N}}{\text{m}^2\text{s}^{-1}} = \text{Nm}^{-2}\text{s}.$$

$$\text{The dimensions of force (F)} = \frac{\text{ML}}{\text{T}^2} \text{ for N is unit of force}$$

$$\text{The dimensions of Area (A)} = \text{L}^2 \text{ for m}^2 \text{ is unit of area}$$

The dimensions of velocity gradient (G) = T<sup>-1</sup> for s<sup>-1</sup> is the unit of velocity gradient.

$$\therefore \text{The dimensions of } \eta = \frac{\text{ML}}{\text{T}^2} \times \frac{1}{\text{L}^2} \div \frac{1}{\text{T}} = \text{ML}^{-1}\text{T}^{-1}$$

It can be noted that  $\eta$  is also expressed in terms of stress.

$$\begin{aligned} \eta &= \frac{\text{Tangential Stress}}{\text{velocity Gradient}} \\ &= \frac{\text{Force per unit Area}}{\text{Velocity Gradient}} \\ &= \frac{\frac{\text{F}}{\text{A}}}{\frac{\Delta V}{\Delta r}} \dots\dots\dots (18.3) \end{aligned}$$

In practice, Poise (pronounced as puaz) is adopted for the unit of  $\eta$  after the name of the scientist Poiseuille (pronounced as puasoy0. The S.I. unit of  $\eta$  is Pa s (Pascal-series or decapoise. 1 decapoise = 1Nm<sup>-2</sup> = 10 poise.

**SELF ASSESSMENT EXERCISE 2**

Determine the frictional force (F) due to a fluid if it has an area of 2 x 10<sup>-3</sup>m<sup>2</sup> in a region of velocity gradient 0.5s<sup>-1</sup> and whose coefficient of viscosity  $\eta$  is 1Nm<sup>-2</sup>s.

**3.3.1 Variation  $\eta$  of with Temperature**

The viscosity of motor oil is 2 poise at 20°C. The viscosity of water is 1 x 10<sup>-3</sup> poise at 10°C. Viscosity decreases with increase in temperature; however, the values of most of motor oils are such that they are independent of temperature.

### 3.4 Poiseuille’s Formula

Poiseuille’s formula helps us to determine the coefficient of viscosity of a liquid by observing the rate of flow of the liquid. It is an expression that relates volume of liquid flowing through a pipe per second ( $V/t$ ), the coefficient of viscosity ( $\eta$  poises), the radius of the pipe ( $r$ ) and the pressure gradient ( $\frac{P}{L}$ ).

The formula was derived by dimensional analysis

$$\frac{V}{t} = \frac{\pi Pr^4}{8 \eta L} \dots\dots\dots (18.4)$$

The value  $\frac{\pi}{8}$  calculated experimentally.

- Where,
- $p$  = difference in pressure between the ends of the pipe
  - $r$  = radius of the pipe
  - $L$  = length of the pipe
  - $\eta$  = coefficient of viscosity

#### 3.4.1 Measurement of $\eta$ by Capillary Flow Method

The apparatus used for this method is as shown in fig. 18.4. It consists of large reservoir below which is connected to a capillary tube of length  $l$ .

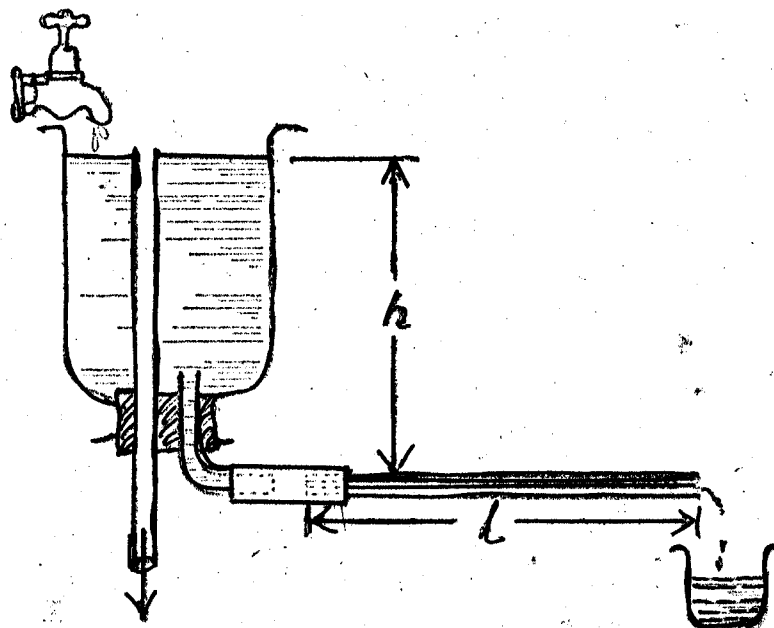


Fig. 18.4

The capillary tube is arranged horizontally to be at height  $h$  below the free surface of the liquid in the reservoir. The liquid is fed into the reservoir faster than the way the liquid flows out of the capillary tube. This is to ensure that the pressure head  $h$  is kept constant. The volume of the liquid flowing through the capillary tube in a given time is collected and measure.  $V/t$  is determined with the knowledge of volume ( $V$ ) and time ( $t$ ). The pressure difference ( $P$ ) across the ends of the tube is given as  $h\rho g$  where:  $h$  is the height of the liquid,  $\rho$  is the density of the liquid, and  $g$  is acceleration due to gravity. Hence the pressure gradient  $P/L$  is determined by suing the formula:

$$\text{Pressure gradient } \frac{P}{L} = \frac{h\rho g}{L}$$

Once using  $P/L$  is known, then by using Poiseuille formula, can be determined easily.

$$\eta = \frac{\pi^4}{8V} \frac{P}{L} \dots\dots\dots (18.5)$$

So far, we have learnt about viscosity, coefficient of viscosity, Poiseuille’s formula and also about the method of measurement of by capillary flow method. Boy now we will learn about Stoke’s law and terminal velocity in the next section.

### 3.5 Stokes’ Law and Terminal Velocity

Under this section, we want to describe the motion of an object that moved through a fluid under gravitational attraction. The example which comes to mind is a spherical ball moving in a tall cylinder of oil. Let us discuss the motion of a spherical ball in a specified oil to explain the concept of terminal velocity before applying it for the Stoke’s law.

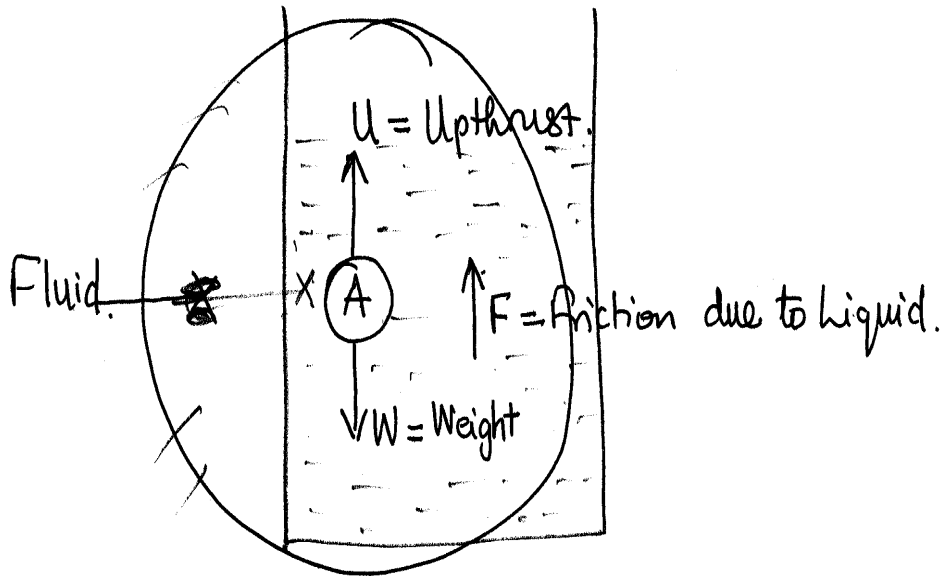


Fig. 18.5

Consider an object A in a liquid X. The object will fall in the liquid under its weight (W). as it moves, it also has an upthrust (U) and frictional force (F) due to the liquid (fig. 18.5). By applying Newton's second law of motion

$$W - U - F = ma \dots\dots\dots (18.6)$$

If we now have a tall jar filled with engine oil as shown in fig. 18.6, and we drop the sphere on its surface X it will be observed that its initial velocity will be zero and the frictional force will be small because the velocity is small or zero at the surface.

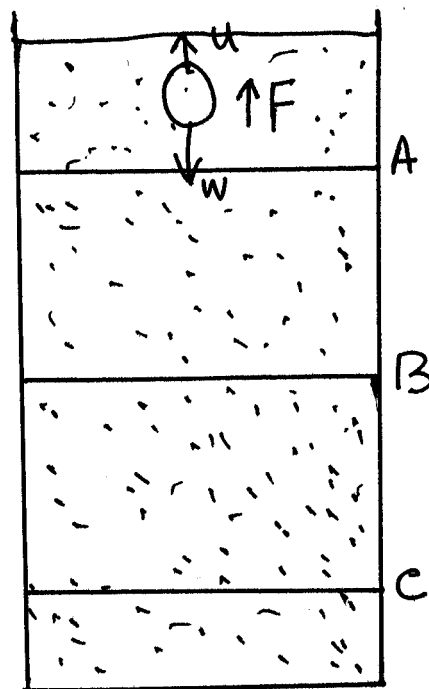


Fig. 18.6

Thus at this stage, since  $F$  approaches zero then by Newton's second law,

$$W - U = ma \dots\dots\dots (18.7)$$

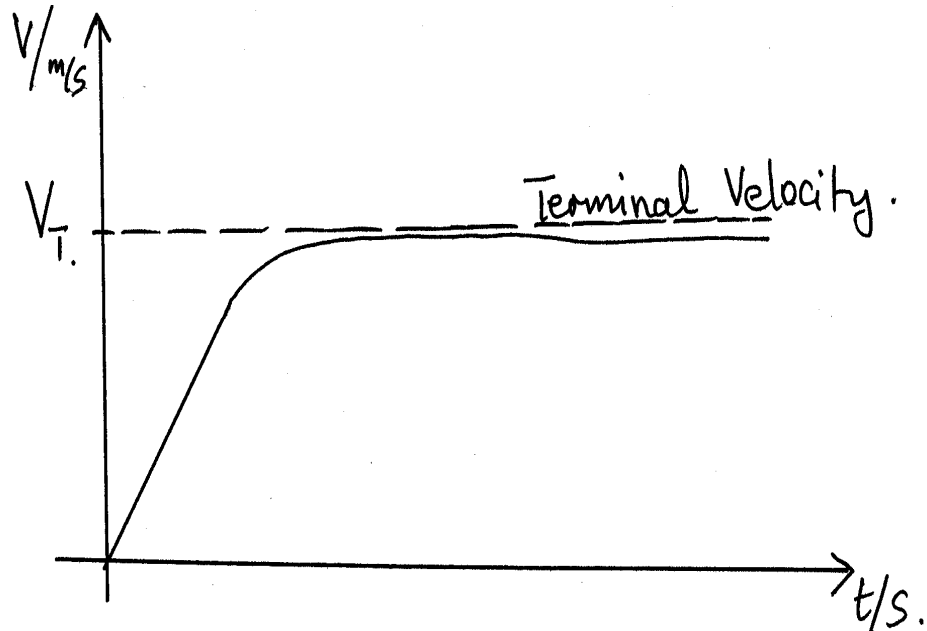


Fig. 18.7

Now, as the sphere goes further down the liquid, the velocity  $V$  increases and so the frictional force  $9f_0$  due to the liquid increases. Thus the net force becomes less. A time is reached when this net is then attained by the sphere which is called the terminal velocity. So in simple words, we can define terminal velocity is the maximum velocity acquired by the body while falling forcibly in a viscous medium. It is this terminal velocity that is applied in Stoke's law. Now we, will learn that what is Stoke's law.

When a sphere of radius  $r$  moves through a viscous fluid of coefficient of viscosity  $\eta$  with a velocity  $v$ , then the frictional force  $F$  acting on the sphere is given by

$$F = 6\pi\eta rV \dots\dots\dots (18.8)$$

The Stoke's law.

Let us go back to the motion of the sphere in the large jar filled with engine oil. When the ball is at the surface we said the unbalanced force is

$$W - U = ma \dots\dots\dots (18.9)$$

Here  $f$  is zero or very small since the velocity is zero or very small. But as the ball passes through points A, B and c we would expect the ball to have attained its terminal velocity.

$\therefore W - U - F = 0$  since the net force has been reduced to zero

$$\therefore F = W - U \dots\dots\dots (18.10)$$

But from Stoke’s law, we know that

$$F = 6\pi\eta rV_T \dots\dots\dots (18.11)$$

Where  $V_r$  is the terminal velocity acquired by the ball. Therefore the above equation expression becomes:

$$\therefore 6\pi\eta rV_T = W - U \dots\dots\dots (18.12)$$

Where  $W = mg = \rho V_s g$

Where,  $\rho =$  density of sphere

$$V_s = \text{volume of sphere} = \frac{4}{3}\pi r^3$$

$$\therefore W = \frac{4}{3}\pi r^3 \rho g \dots\dots\dots (18.13)$$

$$\begin{aligned} \therefore \text{and } U &= \text{upthrust} \\ &= \text{volume of liquid displaced} \times \text{density of liquid} \times \text{acceleration due to gravity.} \\ &= V_1 \times \rho' \times g \end{aligned}$$

Where,  $V_1 =$  volume of liquid displaced  
 $=$  volume of sphere  
 $= \frac{4}{3}\pi r^3$

$$\therefore U = \frac{4}{3}\pi r^3 \rho' g \dots\dots\dots (18.14)$$

Substituting these, we get the expression

$$\therefore 6\pi\eta rV_T = \frac{4}{3}\pi r^3 \rho g - \frac{4}{3}\pi r^3 \rho' g \dots\dots\dots (18.15)$$

On rearranging the terms,

$$\therefore 6\pi\eta rV_T = \frac{4}{3}\pi r^3 \rho' g (\rho - \rho')$$

$$\therefore V_T = \frac{4}{3} \frac{\pi r^3 g}{6 \pi \eta r} (\rho - \rho')$$

We get,

$$V_T = \frac{2}{9} \frac{r^2}{\eta} g (\rho - \rho') \dots\dots\dots (18.16)$$

So with the knowledge of  $r$ ,  $\eta$ ,  $g$ ,  $\rho$  and  $\rho'$ , one can determine the terminal velocity. However we can also define the coefficient of viscosity by rewriting the expression as

$$\eta = \frac{2}{9} \frac{r^2}{V_T} g (\rho - \rho') \dots\dots\dots (18.17)$$

Thus with the knowledge of  $r$ ,  $V_T$ ,  $g$ ,  $\rho$  and  $\rho'$  we can determine the coefficient of viscosity of the oil.

***But now the question is: how do we determine the terminal velocity  $V_T$  experimentally in order to determine  $\eta$  with the knowledge of other parameters (factors) such as  $r$ ,  $g$ ,  $\rho$  and  $\rho'$ ?***

This question will be answered under experimental determination of  $\eta$  with the falling sphere in section 3.5.1.

**SELF ASSESSMENT EXERCISE 3**

Show that Stoke’s law is  $F =$  frictional force in a fluid is dimensionally correct.

It is also important to note that

- The value of  $V$  must be small
- The motion must take place in a large expanse of fluid
- There is no slipping between the fluid and the sphere

Now if the sphere is moving along the axis of a vessel of radius  $R$  there is a small correction to Stoke’s law given as

$$F = 6\pi\eta rV (1 + a \frac{r}{R})$$

Where  $a$  is a numerical coefficient (about 2.4) usually determined experimentally.

### 3.5.1 Measuring $\eta$ by Falling Sphere

This is a good method used to determine the coefficient of viscosity of a liquid through the determination of terminal velocity.

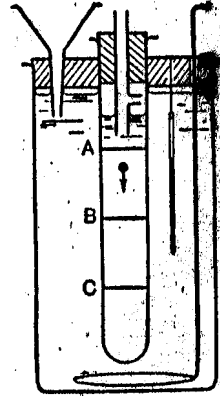


Fig. 18.8

The liquid is put in the tube which is set vertically (fig. 18.8). We use a sphere of 2mm in diameter of the tube is 2cm. The error is negligible even when in theory the diameter of the tube is expected to be large compared with the diameter of the sphere. Hence the correction factor may be ignored. The density of the sphere  $\rho$  is determined using Archimedes' principle. The density of the liquid ( $\rho'$ ) is also determined using the specific gravity bottle i.e. using the relationship

$$\rho' = \rho' r \rho_w$$

Where,  $\rho'$  is density of the liquid,  $\rho' r$  is relative density of liquid, and  $\rho'_w$  is density of water

$$\text{But, } = \rho'_r \quad \frac{\rho'}{\rho_w} = \frac{\text{Mass of Liquid}}{\text{Mass of Equal Volume of Water}}$$

The terminal velocity  $V_T$  is determined by noting the times taken by the sphere to move through AB and BC at  $t_1$  and  $t_2$  respectively. If AB is made to be equal to BC, therefore at terminal velocity  $t_1$  should be equal to  $t_2$  when observed. If not then the experiment has failed because terminal velocity has been attained.

If  $t_1 = t_2$  then terminal velocity has been attained

$$\therefore V_T = \frac{AB + BC}{t_1 + t_2}$$



The micrometer screw gauge is used to determine the radius of the sphere. The value  $\eta$  of can then is determined by using the relation.

$$\eta \frac{2r^2 g (\rho - \rho')}{9V} \text{ poise}$$

#### 4.0 CONCLUSION

The friction in fluids is called viscosity. The coefficient of viscosity is the factor that is used in describing the ability of a fluid to flow. The coefficient of viscosity of a fluid decreases as the temperature increases.

The coefficient of viscosity is defined as the ratio of tangential stress is velocity gradient

$$\eta = \frac{\text{Tangential Stress}}{\text{Velocity Gradient}}$$

Where tangential stress is the tangential force per unit surface area of the layer of the moving fluid and the velocity gradient is the rate of change of the velocities of two surface layers per the distance between them.

Two methods can be used to determine the coefficient of viscosity of a fluid, the capillary flow method from Poiseuille's formula and the falling of sphere method in a fluid which uses the Stoke's law.

#### 5.0 SUMMARY

In this unit, you have learnt the following:

- the resistance offered by a moving fluid is called viscosity;
- the Newtonian fluids frictional force  $F$  is proportional to the velocity gradient  $G$  and the area parallel to the flow of the liquid i.e.  $F = \eta AG$  where,  $\eta$  is constant and defined as the coefficient of a fluid;
- thus  $\eta$  is defined as

$$\eta = \frac{F/A}{G} = \frac{\text{Tangential Stress}}{\text{Velocity Gradient}}$$

- velocity gradient is defined as the rate of change in velocity of fluid layers per the distance between the layers of fluid;
- the viscosity of every fluid decreases as the temperature rises;
- Poiseuille's formula is given as  $\frac{V}{t} = \frac{\pi}{8} \frac{pr^4}{\eta L}$  which describes the relationship between the rate of flow of a fluid with coefficient of viscosity  $\eta$ , the radius of the pipe ( $r$ ) through which the fluid and the pressure gradient  $P/L$  of the flowing fluid;

- the Stoke's law related the frictional force, the weight of the object and the upthrust it experiences as it falls through fluids when it has attained

$$F = W - U$$

A terminal velocity:

- the terminal velocity is the velocity acquired by a falling object in a fluid when the net force of the frictional force  $F$ , its weight  $W$  and upthrust  $U$  is zero

$$W - U - F = 0$$

### ANSWER TO SELF ASSESSMENT EXERCISE 1

Velocity gradient is the rate of change of velocity of the moving layers of fluid per the change in distance between the moving layers.

For more refer to section 3.2.

### ANSWER TO SELF ASSESSMENT EXERCISE 2

$$\begin{aligned} F &= \eta AG \\ &= 1\text{Ns/m}^2 \times 2 \times 10^{-3}\text{m}^2 \times 0.5\text{s}^{-1} \\ &= 10^{-3}\text{N} \end{aligned}$$

The viscosity of every fluid decreases as the temperature rises, and the change with temperature is very considerable. In Table 3.1 below, values of  $\eta$  for various liquids are given:

**Table 18.1: Coefficient of Viscosity of Liquids**

LIQUID	$\eta$ (POISE)	TEMPERATURE
WATER	$1.79 \times 10^{-2}$	0°C
WATER	$1.0 \times 10^{-3}$	10°C
WATER	$6.6 \times 10^{-3}$	40°C
GLYCERINE	46	0°C
GLYCERINE	3.5	30°C
PITCH	$5.1 \times 10^{11}$	0°C
PITCH	$1.19 \times 10^{-2}$	100°C
ENGINE OIL	2.0	20°C

**ANSWER TO SELF- ASSESSMENT EXERCISE 3**

$$\begin{aligned}
 \text{Dimension for } \eta &= \text{ML}^{-1}\text{T}^{-1} \\
 \text{Dimension for } r &= \text{L} \\
 \text{Dimension for } V &= \text{LT}^{-1} \\
 \therefore \eta r V &= \text{ML}^{-1}\text{T}^{-1} \times \text{L} \times \text{LT}^{-1} \\
 &= \text{MLT}^2
 \end{aligned}$$

$$\text{But the dimensions of force (F)} = \text{MLT}^2$$

So, Stoke's law is dimensionally correct.

Note that  $6\pi$  has no dimensions.

**6.0 TUTOR-MARKED ASSIGNMENT**

1. A small oil drop falls in air with a terminal velocity of  $2 \times 10^{-2}$  m/s. The density of the oil is  $900 \text{ kg/m}^3$ , the coefficient of viscosity of air is  $2 \times 10^{-5} \text{ Nsm}^{-2}$  and  $g = 10 \text{ m/s}^2$ . Determine the radius of the drop. (Neglect the upthrust in air)
2. A small sphere of radius 2.0mm and density  $8.0 \times 10^3 \text{ kg/m}^3$  is released from rest at the surface of a long column of a viscous liquid of density  $1.3 \times 10^3 \text{ kgm}^{-3}$ . The viscous force  $F$  opposing the motion is proportional to the velocity  $V$  in m/s of the sphere and is given by the formula  $F = 0.057V$ . Calculate the terminal velocity of the sphere?

**7.0 REFERENCES/FURTHER READING**

- Awe, O. and Okunola, O. O. (1986). *Comprehensive Certificate Physics*, Ibadan: University Press.
- Ference, M. (Jnr.), Lemon, H.B. and Stephenson, R. J. (1970). *Analytical Experimental Physics*, Chicago: The University of Chicago Press.
- Feynman, R. P., Leighton, R. B. and Sands, M. (1971). *The Feynman Lectures on Physics*, California: Addison – Wesley Publishing Company Limited.
- Flowers, B. H. and Mendoza, E. (1970). *Properties of Matter*, London: John Wiley and Sons Limited.
- Noaks, M. A. (1963). *New Intermediate Physics*, Canada: Macmillan and company Limited.

Soars, F. W., Zemansky, M.W. and Young, H. D. (1980). *College Physics Addison* – London: Wesley Publishing Company.

Tyler, F. (1966). *Heat and Thermodynamics*. London: Edwards Arnold Publisher Limited.

Wilkinson, J. (1983). *Essentials of Physics*, Australia: Macmillan Education Publishers.

Zemansky, M.W. (1968). *Heat and Thermodynamics*. New York: McGraw-Hill Book Company.

## UNIT 4 SURFACE TENSION

### CONTENTS

- 1.0 Introduction
- 2.0 Objectives
- 3.0 Main Content
  - 3.1 Concept of Surface Tension
    - 3.1.1 Molecular Explanation of Surface Tension
  - 3.2 Coefficient of Surface Tension
  - 3.3 Force of Cohesion and Force of Adhesion
    - 3.3.1 Angle of Contact
  - 3.4 Excess Pressure in Bubbles and Curved Liquid Surfaces
    - 3.4.1 Excess Pressure on curved Liquid Surfaces
    - 3.4.2 Excess Pressure in Soap Bubbles
  - 3.5 Capillarity: The Rise and Fall of Liquids in Capillary Tubes
  - 3.6 Measuring Surface Tension
    - 3.6.1 Capillary Rise Method
  - 3.7 Variation of Surface Tension with Temperature
  - 3.8 Surface Tension and Surface Energy
- 4.0 Conclusion
- 5.0 Summary
- 6.0 Tutor-Marked Assignment
- 7.0 References/Further Reading

### 1.0 INTRODUCTION

Surface tension is another property of fluids that we have to examine in this unit after the treatment of viscosity.

You would have observed that when water is dripping very slowly from a partially closed tap, the water comes out in form of spherical drops and not as a continuous stream but as a succession of drops. Why do they do so?

It has also been observed that a clean needle if placed carefully on a water surface makes a small depression on the surface and stays at rest there without sinking, despite the fact that its density is greater than that of water. When a capillary tube is dipped in water, it has also been observed that the water level in the tube rises whereas when a similar tube is dipped in mercury, the mercury level is depressed. Some water insects have also been observed to be able to walk, as it were, on the surface of water. All these observations and common phenomena are regarded as a consequence of surface tension.

The formation of soap bubbles could also be explained through the existence of surface tension. Furthermore, most plants draw their water from the soil by capillary rise of water through the hair like secondary roots.

The study of surface tension is very important as it cuts across the various fields in science. In this unit, we shall study the concepts of surface tension. You will also studied the applications of surface tension. The phenomenon of capillary is also discussed in details here.

## 2.0 OBJECTIVES

At the end of this unit, you should be able to:

- identify situations where the concept of surface tension in fluids is illustrated
- explain the concept of surface tension using molecular ideas
- define the coefficient of surface tension
- distinguished between adhesive and cohesive forces
- explain the meaning of angle of contact
- state the excess pressure in bubbles and curved liquid surfaces in relation to the surface tension and radius of the bubble or the meniscus
- state the relationship between
  - The height to which a liquid rises in a capillary tube and surface tension.
  - The depth to which a liquid falls in a capillary tube and surface tension.
- determine the surface tension of a liquid by capillary rise or any other method
- use Jaeger's method to show variation of surface tension with temperature
- define surface tension in terms of surface energy
- solve problems on the surface tension phenomenon.

## 3.0 MAIN CONTENT

### 3.1 Concept of Surface Tension

Molecules at the surface of water and other liquids have more energy than those in the bulk volume of the liquid. This observation is what makes the surface acts like a film or skin covering the liquid. For example, a light insect called the water boatman can move across water

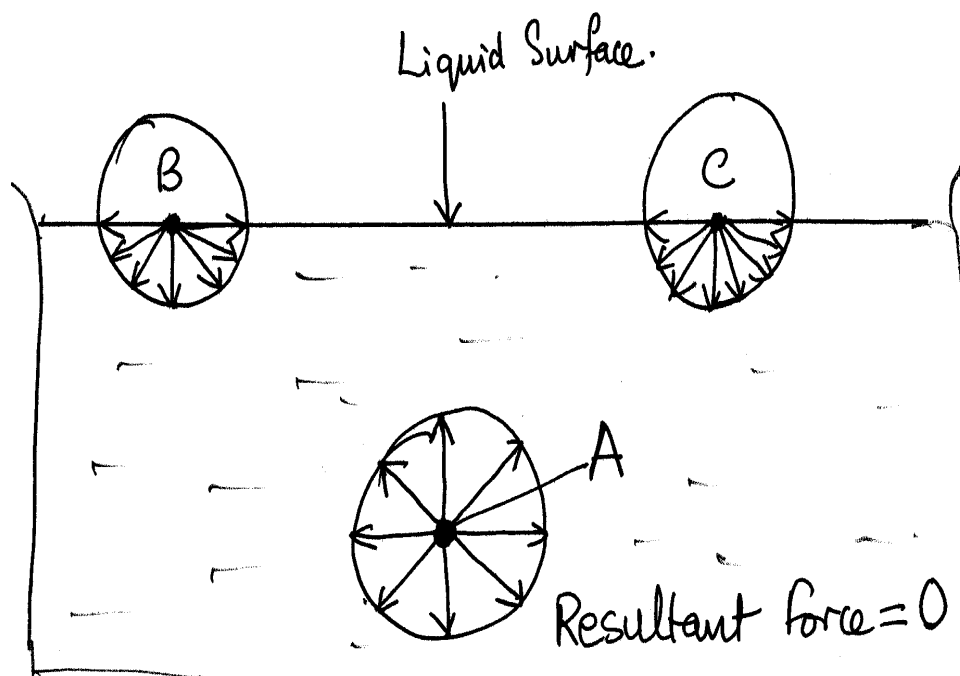
without falling through. Mosquito larva can cling to understand of the surface of water in a swamp. A light steel needle also can be floated on the surface of water. All the above observations are due to the surface tension of water.

### SELF ASSESSMENT EXERCISE 1

What is surface tension? Give some examples of where surface tension could be identified.

#### 3.1.1 Molecular Explanation of Surface Tension

In this section we shall explain how the molecules in a liquid surface have more energy than those inside the liquid.



**Fig. 19.1: Surface Tension**

Consider three molecules A, B and C such that molecules B and C are at the same surface of the liquid while molecule A is below the surface liquid. It will be observed that molecule A will be attracted equally round by neighbouring molecules inside the sphere of molecular attraction as shown in (fig. 19.1). Now look at the two other molecules B and C on the surface of the liquid. These molecules on the surface of a liquid however are attracted by its neighbouring molecules to the sides and downwards but not upward. The resultant of such molecular attractions thus tends to pull the surface molecules into liquid. It is this tendency to pull the surface molecules into the liquid that causes the

surface to become as small as possible. The surface behaves, as if it were, tightened into an elastic film.

A molecule, which reaches the surface of the liquid, does work in overcoming this force of attraction so it has a greater energy than those molecules in the bulk of the liquid. Consequently, the surface has energy. At equilibrium, the surface will have a minimum energy. This means that the number of molecules in the surface is a minimum. So the area of the surface of a given volume of liquid is a minimum.

A sphere is the volume of a liquid whose surface area is minimum. This is why raindrops are spherical.

Small mercury drops on glass form small spheres but large drops are flattened on the top owing to gravitational force, which lowered the centre of gravity as much as possible. (See fig. 19.2).



**Fig. 19.2: Drops of Mercury**

Leads shots are manufactured by spraying molten lead from the top of a tower. The liquid forms spheres as they fall due to surface tension.

### 3.2 Coefficient of Surface Tension

Surface tension is a property of a liquid. The magnitude of a surface tension across/perpendicular to a unit length is known as the coefficient of surface tension. Surface tension varies with purity of the liquid and temperature. The coefficient of surface tension  $\gamma$  is defined as the force per unit length in the surface acting perpendicular to one side of a line in the surface.

$$\gamma = \left[ \frac{\text{Force}}{\text{Lenght}} \right]$$

Surface tension is independent of the surface area. The unit of  $\gamma$  is  $\text{Nm}^{-1}$ . The dimension of surface tension is  $\text{MT}^{-2}$ .

$\Gamma$  varies with the temperature of the liquid. At  $20^\circ\text{C}$ ,  $\gamma$  is the value of  $7.2 \times 10^{-2}\text{Nm}^{-1}$  for water, whereas at the same temperature, its value is  $4.5 \times 10^{-1}\text{Nm}^{-1}$  for mercury.



The surface tension  $\gamma$ , of liquid decrease with temperatures, molecules have higher kinetic energy. They are thus, relatively further apart from neighbouring molecules. This therefore reduces the inward force hence the work done against force is less. Molecules in the surface now have less energy that at lower temperatures. That is, the surface tension is less at high temperatures than at lower temperature.

If  $\gamma = \frac{T}{l}$   
 $\therefore T = \gamma l \dots\dots\dots (19.1)$

For a rectangular slide with edge touching water surface as shown in fig. 19.3:

$T = \gamma (2a + 2b) \dots\dots\dots (19.2)$

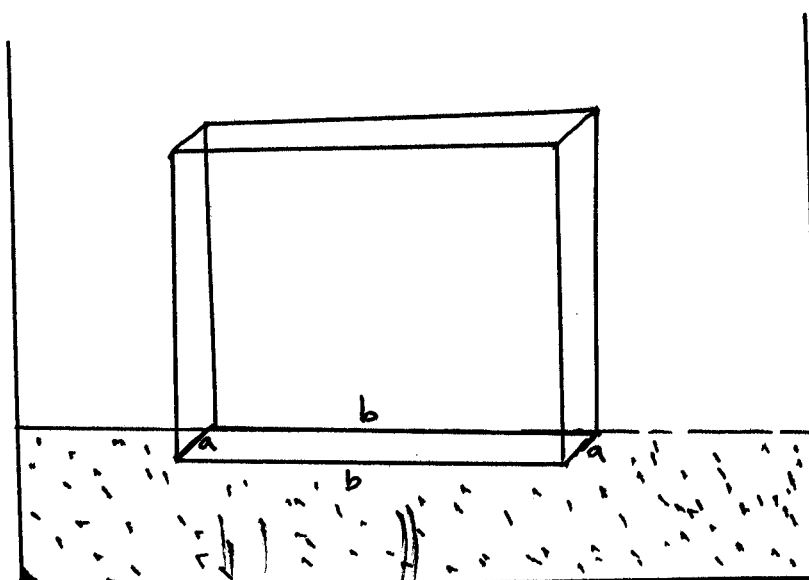


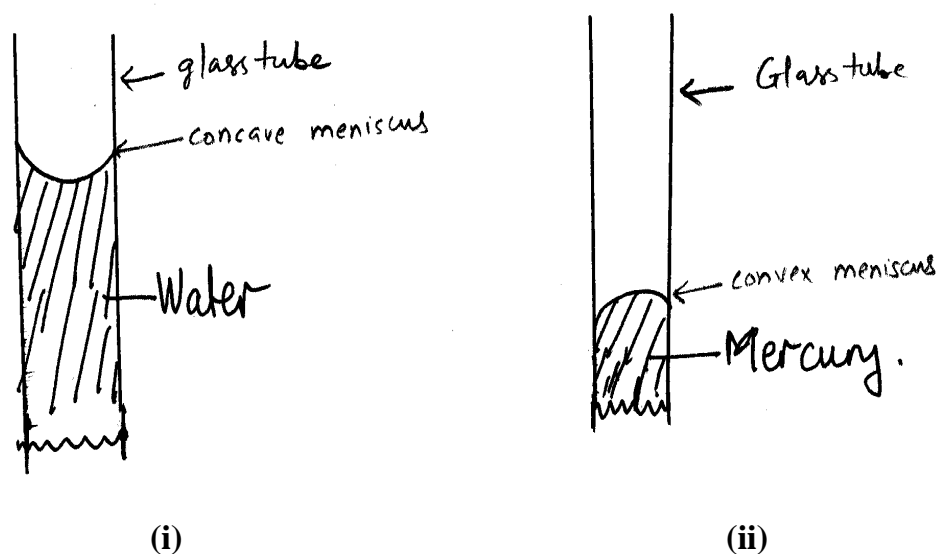
Fig. 19.3

### 3.3 Force of Cohesion and Force of Adhesion

Molecular forces between like molecules are called forces of cohesion. For example two water molecules have cohesion forces between them. The molecular forces between unlike molecules are called forces of adhesion. For example, the force between molecules of water and those of the glass vessel will constitutes adhesive forces.

Water wets are clings to clean glass because the adhesive forces between glass and water molecules are greater than the cohesive forces of water. Conversely, mercury does not wet clean glass but shrinks away from it because the adhesive forces between mercury and glass molecules a re less than the cohesive forces of mercury.

How can you explain the situations where by the meniscus of water in a glass and the meniscus of mercury in the same glass as shown in fig. 19.4 (i) & (ii)?



**Fig. 19.4**

Fig. 19.4 (i) shows water in a glass tube which produces a meniscus (concave meniscus). It curves upwards. Whereas, fig. 19.4 (ii) shows mercury in glass which produces a meniscus (convex meniscus) that curves downwards. These two types of surfaces can be explained through the concepts of adhesive and cohesive forces between the molecules of the liquid and the container.

In fig. 19.4 (i) the adhesive forces between the water molecules and the glass molecules are greater than the cohesive force between the water molecules. On contrary, in fig. 19.4(ii), the adhesive forces between the mercury molecules and the glass molecules are less than the cohesive forces between the mercury molecules.

### 3.3.1 Angle of Contact

The angle of contact is another property used to show the different kinds of meniscus (concave and convex) we obtain when a liquid is contained in a tube. Angle of contact ( $\theta$ ) between a liquid and a solid is defined as the angle measured through the liquid between the tangent to the liquid surface where it touches the solid surface and the solid surface itself.

For example the angle of contact for pure water in contact with clean glass taken as is zero  $\theta = 0$  (See fig. 19.5)

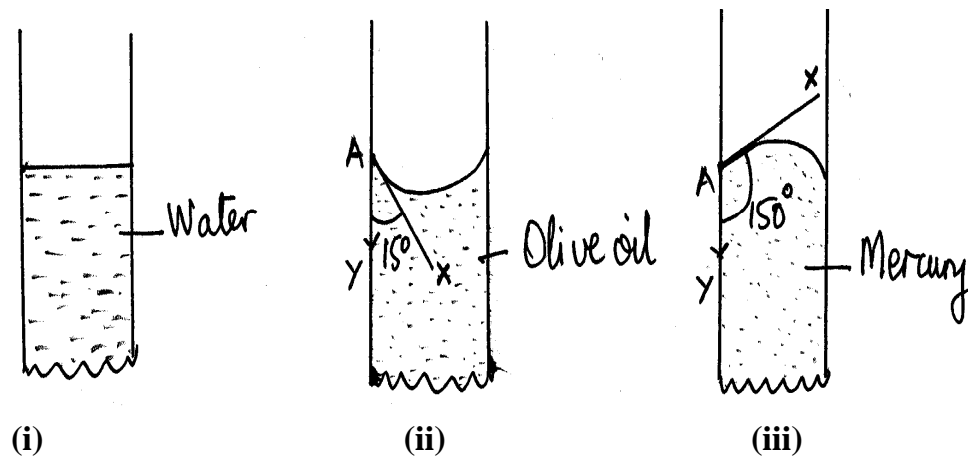


Fig. 19.5

The angle of contact for olive oil is  $15^\circ$  (fig. 19.5 (ii)), and the angle of contact for mercury is  $150^\circ$ . It is to be noted that liquids that make obtuse angles ( $\theta > 90^\circ$ ) of contact with glass or any other solid surface do not wet the surfaces (i.e. mercury and glass). However, liquids with acute angles ( $\theta < 90^\circ$ ) of contact wet the surface (i.e. water and glass).

In manufacture of raincoats, garment fibers are treated chemically so that the acute angle made by water with the fiber is changed to an obtuse angle, thus the water then forms drops, which can be shaken off from the raincoat.

### 3.4 Excess Pressure in Bubbles and Curved Liquid Surfaces

The curvature of a liquid or a bubble formed in a liquid is related to the surface tension of the liquid. In this section, we would relate surface tension with the excess pressure that exists in the formation of bubbles in liquids or in air and curved liquid surfaces.

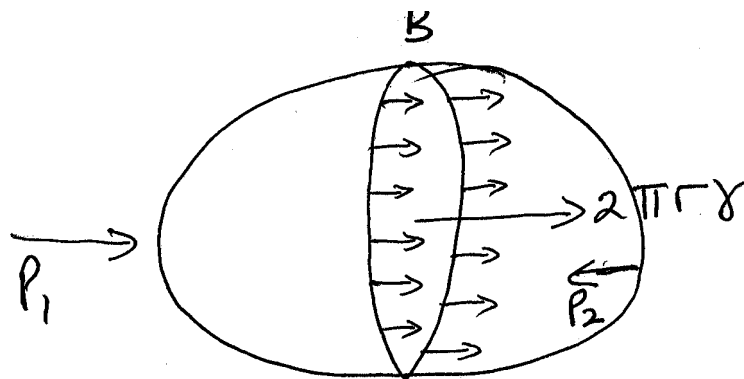


Fig. 19.6: Excess Pressure in a Bubble

Consider a bubble formed inside a liquid as shown in fig. 19.6.

We shall consider the equilibrium of one half of B of the bubble.  
 The total force due to the surface tension =  $2\pi r\gamma$  where  $2\pi r$  is the circumference around which  $\gamma$  the surface tension acts.

The force due to the Pressure  $P_1$  is given by  $P_1\pi r^2$ .  
 The total force from left to right =  $\gamma 2\pi r + P_1\pi r^2$  ..... (19.2)  
 The force from right to left =  $P_2\pi r^2$  ..... (19.3)  
 Since the bubble is at equilibrium

$$\therefore P_2\pi r^2 = \gamma 2\pi r + P_1\pi r^2 \text{ ..... (19.4)}$$

On rearranging the terms,

$$(P_2 - P_1) \pi r^2 = 2\pi r\gamma$$

$$\therefore (P_2 - P_1) = \frac{2\pi r\gamma}{\pi r^2}$$

We get

$$(P_2 - P_1) = \frac{2\gamma}{r}$$

$$\therefore \text{Excess Pressure } P = (P_2 - P_1) = \frac{2\gamma}{r} = \text{ ..... (19.5)}$$

### 3.4.1 Excess Pressure on Curved Liquid Surfaces

When capillary tubes are dipped in liquids, we have curved surfaces otherwise known as meniscus as shown in (fig. 19.7).

For a curved surface or meniscus where  $r$  is the radius of curvature and  $\gamma$  is the surface tension.

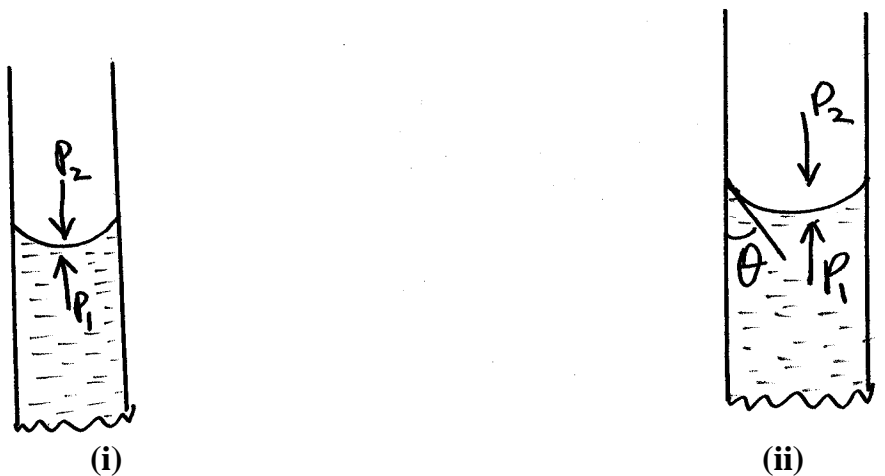


Fig. 19.7: Excess Pressure in Liquids in Capillary Tube

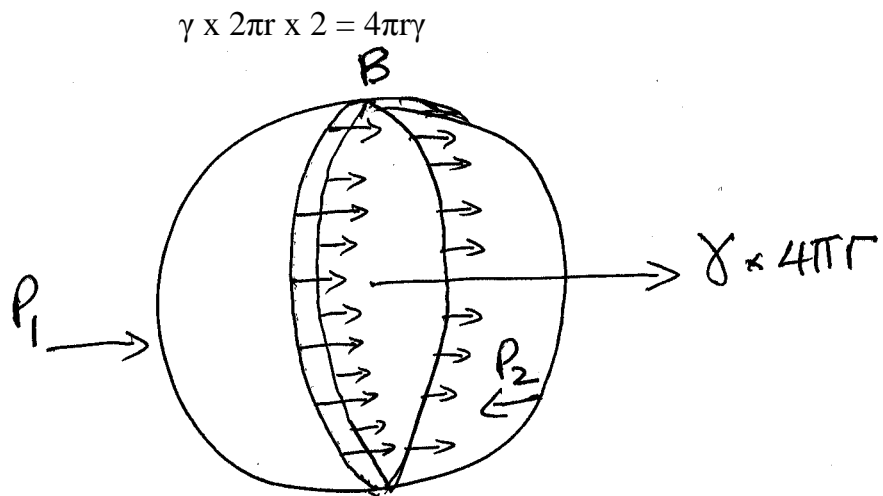
The excess pressure is also expressed as  $P = \frac{2\gamma}{r}$  ..... (19.6)

If the angle of contact is  $\theta$  then the excess pressure is given as

$$P = \frac{2\gamma \cos \theta}{r} \dots\dots\dots (19.7)$$

**3.4.2 Excess Pressure in Soap Bubbles**

A soap bubble has two liquid surfaces in contact with air. One is inside the bubble while the other is outside the bubble. The force of one half B of the bubble due to the surface tension is thus:



**Fig. 19.8: Excess Pressure in a Soap Bubble**

Force due to Pressure $P_1$	=	$P_1\pi r^2$
Force due to surface tension	=	$4\pi r\gamma$
$\therefore$ Total force from left to right	=	$P_1\pi r^2 + 4\pi r\gamma$ ..... (19.8)
Total force due to Pressure $P_2$	=	$P_2\pi r^2$ ..... (19.9)

At equilibrium, therefore, we can write

$$P_2\pi r^2 = 4\pi r\gamma + P_1\pi r^2 \dots\dots\dots (19.10)$$

$$\therefore P_2\pi r^2 - P_1\pi r^2 = 4\pi r\gamma$$

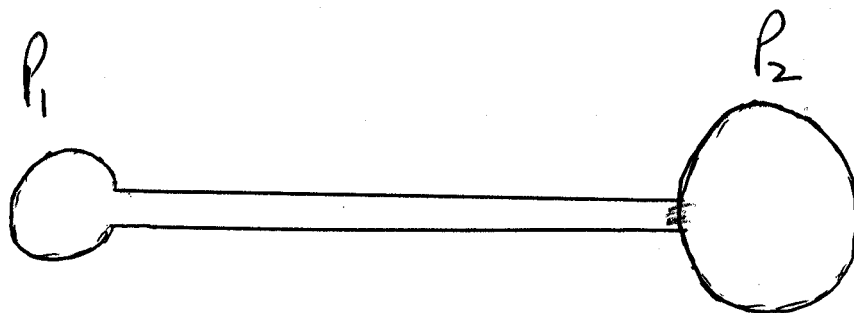
$$\therefore (P_2 - P_1)\pi r^2 = 4\pi r\gamma$$

On rearranging, we obtain the expression for excess pressure as

$$\therefore (P_2 - P_1) = \frac{4\pi r\gamma}{\pi r^2}$$

$$\therefore \text{Excess Pressure } P = (P_2 - P_1) = \frac{4\gamma}{r} = \dots\dots\dots (19.11)$$

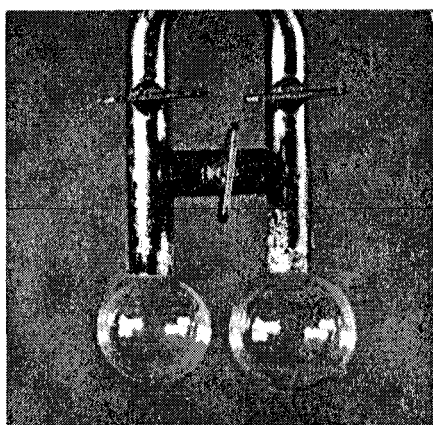
From the above expressions on excess pressure, it will be observed that the excess pressure ( $P$ ) is inversely proportional to the radius of the bubble or the curved surface. A smaller soap bubble has a greater pressure inside it than a larger bubble. This is demonstrated when such bubbles are formed on the ends of a tube. The smaller decreases in size while the larger grows slightly due to airflow (Fig. 19.9).



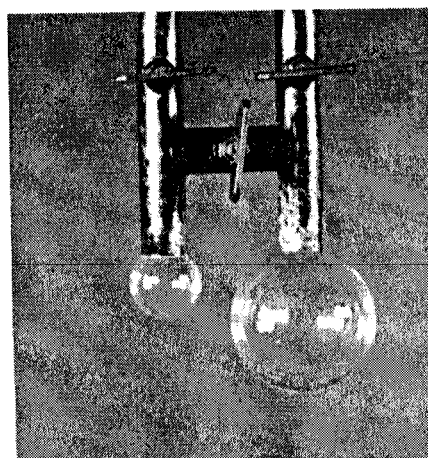
**Fig. 19.9**

When the air flow ceases, the air pressure inside has equalized. Thus the radius of the film to which the small bubble collapse is equal to the radius of large bubble on the other side. Fig. 19.10 shows two soap bubbles of unequal size blown on the ends of a tube. Communication between them is being prevented by a closed tap in the middle. If the tap is opened, the smaller bubble is observed to collapse gradually and the size of the larger bubble increases.

The explanation for this observation is that the pressure  $P_1$  in the smaller bubble is greater than  $P_2$ , the pressure in the large bubble. Consequently, air flows from  $P_1$  to  $P_2$ .



(a)



(b)

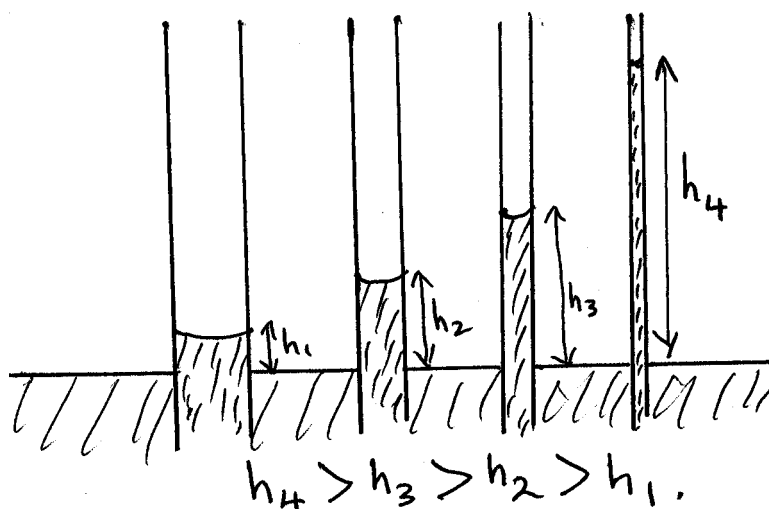
**Fig. 19.10**

## SELF ASSESSMENT EXERCISE 2

Given that the coefficient of surface tension  $\gamma$  for soap bubble is  $25 \times 10^{-3} \text{ Nm}^{-1}$ , if its radius is 0.5cm. Calculate the excess pressure in a soap bubble.

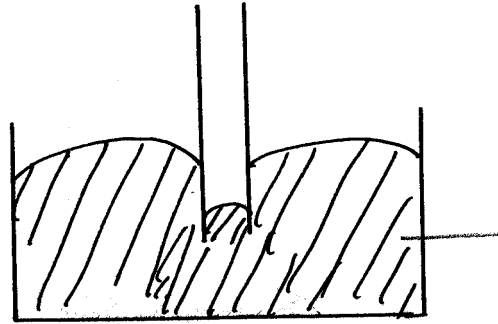
### 3.5 Capillarity: The Rise and Fall of Liquids in Capillary Tubes

You would have observed that when different types of tubes (of varying diameter) are dipped in water, the water rises differently in such tubes. The height is greatest with tubes with smallest diameter. Such tubes are called capillary tubes. In other words, a tube with a fine and uniform bore throughout its length is called a capillary tube as shown in fig. 19.11.



**Fig. 19.11: Capillary Rise in Tubes**

The behaviour of liquids in capillary tubes can be associated with surface tension of liquids. For example, water rises in capillary tubes. In case of mercury, the level of the liquid falls (fig. 19.12) as will be discussed later in this section.



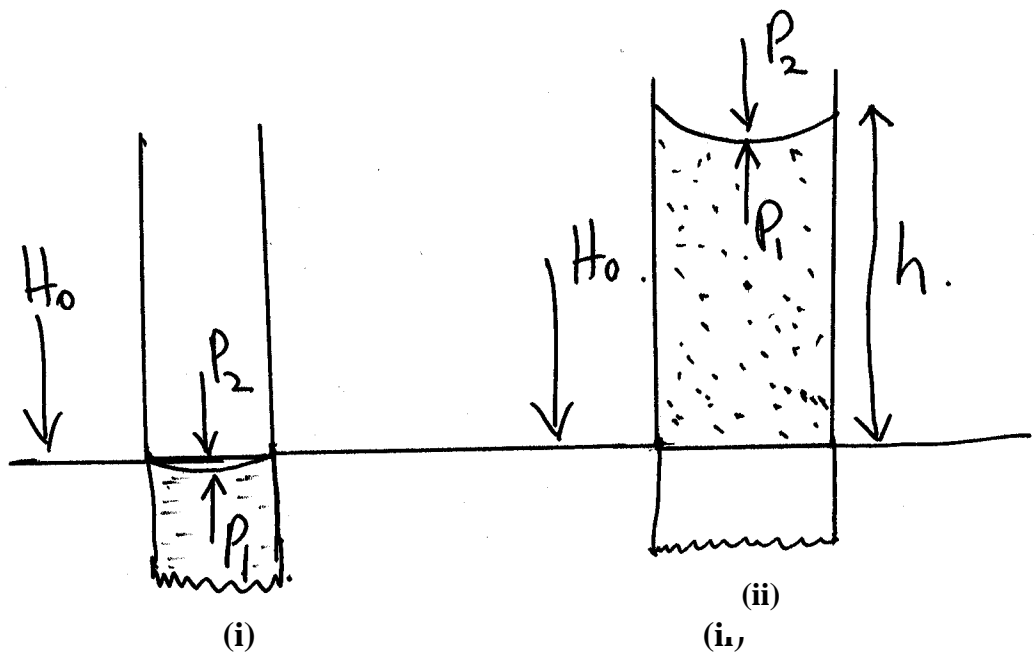
**Fig. 19.12 Mercury in Capillary Tube**

With our previous knowledge of angle of contact  $\theta$ , and excess pressure on one side of a curved liquid surface, we can deduce that some liquids will rise in a capillary tube whereas some will be depressed, that is, will fall.

The excess pressure formula

$$P_2 - P_1 = \frac{2\gamma}{r}$$

For a bubble in water also applies to the excess pressure across a curved liquid surface of radius  $r$  which is spherical in shape. We shall therefore apply the relationship to the meniscus of water in a clean glass capillary tube when the angle of contact is zero.



**Fig. 19.13: Capillary Rise of Liquid**

Fig. 19.3 (i) shows the meniscus when the capillary tube is first placed inside water with zero angle of contact. The meniscus curves upwards with radius  $r$  equal to that of the capillary tube. The pressure  $P_2$  above



the meniscus is greater than the pressure  $P_1$  just below by  $\frac{2\gamma}{r}$ . But  $P_2 = H$ , where  $H$  is the atmospheric pressure and  $P_1 = H$ , since the level of water is the same inside and outside the tube.

This, obviously, is impossible thus the meniscus in fig. 19.13 is therefore unstable. In order to  $P_2$  make greater than  $P_1$  by  $\frac{2\gamma}{r}$ , the water will rise to a height  $h$ , above the outside as shown in fig. 19.13 (ii).

Here the pressure above the meniscus is still  $H$  but the pressure is now  $H - hpg$  from the hydrostatic pressure where  $p$  is the density of the liquid.

$$\text{Hence, } P_2 - P_1 = H - (H - hpg) = \frac{2\gamma}{r}$$

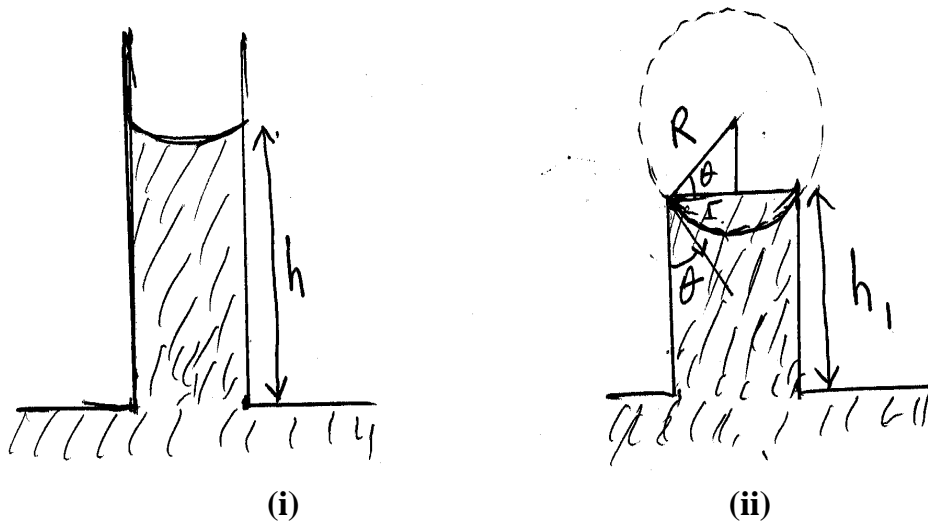
$$\therefore P_2 - P_1 = hpg = \frac{2\gamma}{r}$$

$$\therefore hpg = \frac{2\gamma}{r} \dots\dots\dots (19.12)$$

Suppose the liquid has angle of contact  $\theta$  the liquid then rises to a height  $h$  given by

$$hpg = \frac{2\gamma}{r} \cos \theta \dots\dots\dots (19.13)$$

This is obtained from the fact that the vertical component of  $\gamma$  is  $\gamma \cos \theta$



**Fig. 19.14: Rise of Liquid in a Capillary Tube**

Fig. 19.14 (ii) shows what happens when the capillary tube in fig. 19.14

(i) is pushed down into water so that the height  $h_1$  of the tube above the water outside is less than  $h$ . Note that the liquid does not overflow. The meniscus at the top of the tube now forms a surface of radius  $R$  bigger than  $r$  of the capillary tube and makes an acute angle of contact  $\theta$  with the glass.

$$\text{Excess pressure} = h_1 \rho g = \frac{2\gamma}{R}$$

$$\text{From fig. 19.14 (i) Excess pressure} = h \rho g = \frac{2\gamma}{r}$$

$$\therefore \frac{h_1}{h} = \frac{2\gamma}{r} = \cos \theta \dots\dots\dots (19.14)$$

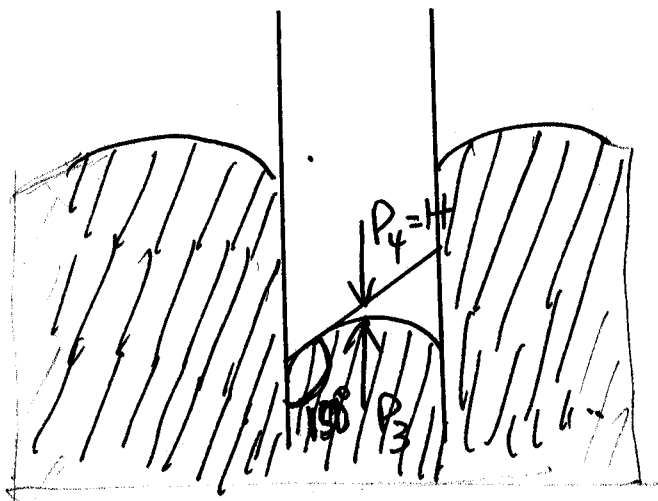
From geometrical point of view, it can be shown that

$$\cos \theta = \frac{r}{R}$$

Thus, the angle of contact can be determined.

**SELF ASSESSMENT EXERCISE 3**

Given that  $h_1 = 4\text{cm}$  and  $h = 8\text{cm}$ . Determine the angle of contact of the liquid (as shown in fig. 19.14)?



**Fig. 19.15: Fall of Liquid in a Capillary Tube**

Fig. 19.15 shows what happens when a glass tube is dipped into mercury which has an obtuse angle of contact  $150^\circ$  with the glass. In this case the equilibrium is obtained when the mercury falls to a depth of  $h$  below the outside level. Pressure  $P_3$  below the curve is greater than  $P_4$  or  $H$ , the atmospheric pressure above.

$$P_3 - P_4 = \text{Excess Pressure} = \frac{2\gamma \cos 30}{r}$$

Since  $\cos(180^\circ - 150^\circ) = \cos(30^\circ)$

If  $P_3 = H + hpg$   
and  $P_4 = H$

$$\therefore P_3 - P_4 = (H + hpg) - H = \frac{2\gamma \cos 30}{r}$$

$$\therefore P_3 - P_4 = hpg = \frac{2\gamma \cos 30}{r}$$

$$\therefore hpg = \frac{2\gamma \cos 30}{r}$$

#### SELF ASSESSMENT EXERCISE 4

A vertical glass capillary tube of radius  $2 \times 10^{-4} \text{ m}$  is placed inside clean water in a beaker

- Calculate the height that the water will rise. The tube is now pushed down until its top is 4cm above the water level outside.
- Describe what happens to the water inside the tube (surface tension of water =  $7.2 \times 10^{-2} \text{ Nm}^{-1}$  assume  $g = 10 \text{ ms}^{-2}$ ).

### 3.6 Measuring Surface Tension

So far you have learnt about surface tension and the capillary tubes. In the next section, you will learn about measuring of surface tension.

From what we have discussed so far on surface tension, is it possible to measure the surface tension of water experimentally?

Surface tension of water may be determined by two methods:

- By capillary rise
- By microscopic slide

But here, we will discuss only about the capillary rise method.

### 3.6.1 Capillary Rise Method

#### Theoretical Background

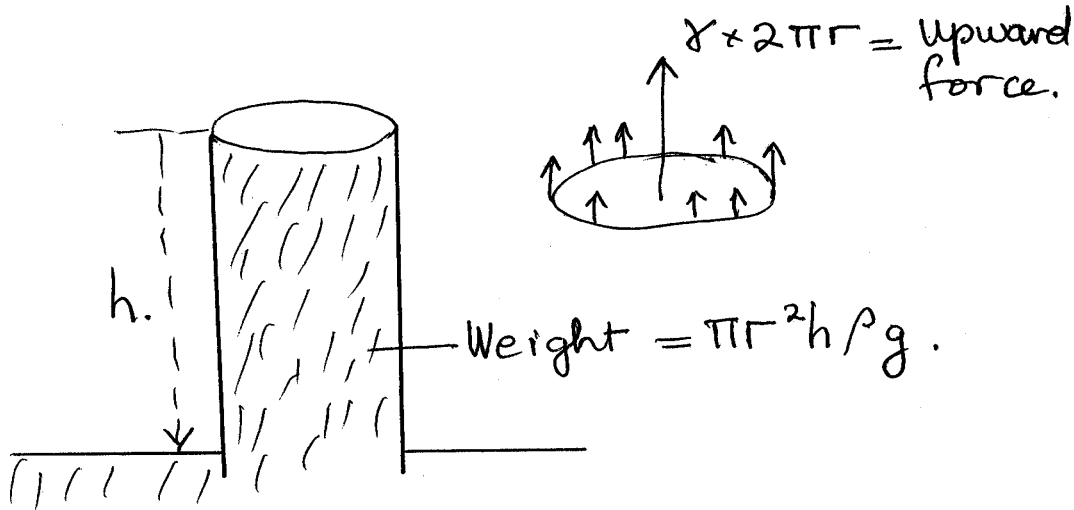


Fig. 19.16

Let  $\gamma$  be the surface tension of the liquid and it is defined as force per unit length. Thus the total upward force in the capillary tube due to the surface tension is given as  $2\pi r\gamma$ . This force is balanced by the weight of the liquid of the column  $h$  above the outside level of the liquid.

The volume of the liquid =  $\pi r^2 h$

The mass of the liquid = volume x density =  $\pi r^2 h \times \rho$

$\therefore$  The weight of the liquid =  $\pi r^2 h \rho g = mg$

Since the upward force balanced the weight, the downward force

$\therefore 2\pi r\gamma = \pi r^2 h \rho g$

$\therefore \gamma = \frac{\pi r^2 h \rho g}{2\pi r}$

$\gamma = \frac{\pi r^2 h \rho g}{2\pi r} \dots\dots\dots (19.15)$

thus if  $r$ ,  $h$ ,  $\rho$  and  $g$  are known  $\gamma$  can be determined.

Thus in the use of capillary rise of water in measuring surface tension, the following assumptions are made:

- The angle of contact are made.
- The small amount of liquid above the bottom of the meniscus is negligible as shown in fig. 19.17

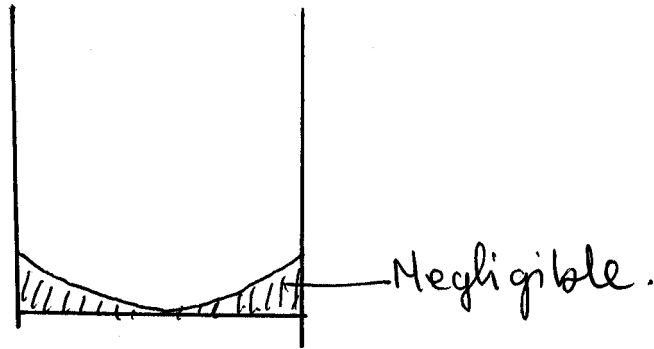


Fig. 19.17

### Precautions

- A clean glass capillary tube is used such that the angle of contact is zero.
- Pure water or clean water free of impurities is used.

### Required

- Clean water
- Clean capillary tube.
- A traveling microscope with a vernier scale to measure  $h$ . Where  $h$  is the top of the meniscus level of water in the beaker.

A pin P is made to touch the surface of the water (fig. 19.18).

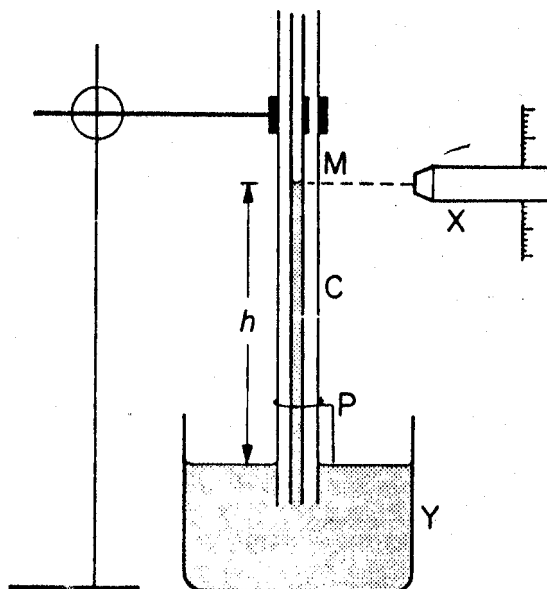


Fig. 19.18

- the radius  $r$  of the tube is measured by cutting the tube and using the traveling microscope to measure the diameter.

Where  $r = D/2$

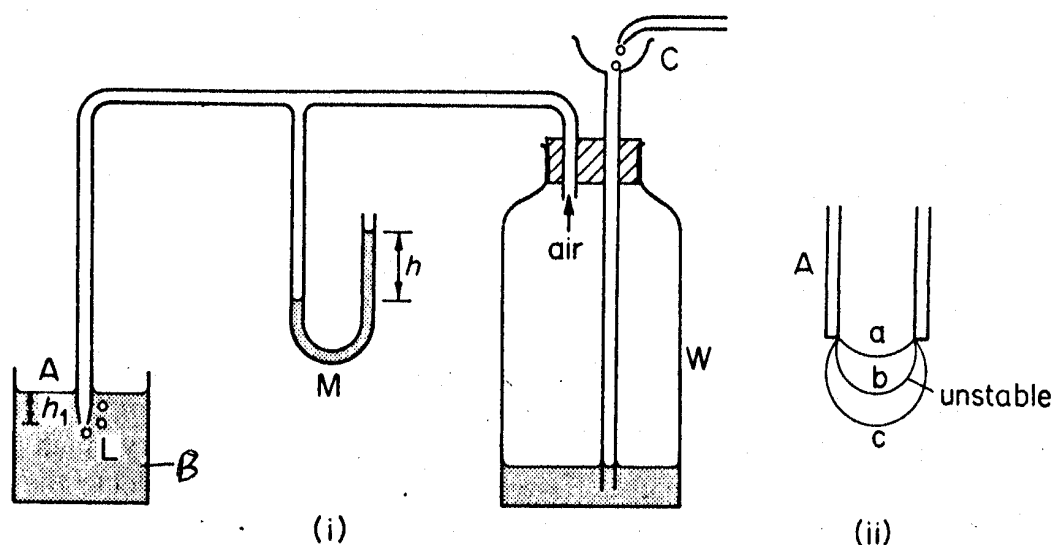
Having determined  $r$ ,  $h$  and using the values of  $\rho$  (density of liquid) and  $g$  (acceleration due to gravity), then the surface tension  $\gamma$  can be obtained.

### 3.7 Variation of Surface Tension with Temperature

#### Jaeger's Method

The rise in a capillary tube is not suitable for measuring the variation of surface tension of water with temperature. This is because the water in the beaker can be varied in temperature but the water in the capillary tube will not be at the same temperature.

Thus, Jaeger used excess pressure in a bubble formed inside water to measure how the surface tension  $\gamma$  for water varies with temperature.



**Fig. 19.19: Jaeger's Apparatus**

From fig. 19.19 a bubble is formed slowly at the end of the tube A dipped into a beaker of water B by air from a vessel W. an oil manometer M is used to measure the pressure inside the bubble as it grows, by forming a bubble inside a liquid, and measuring the excess pressure, Jaeger found how the surface tension of a liquid varied with temperature.

$$\text{Excess pressure} = h\rho g - h_1\rho_1 g = \frac{2\gamma}{r}$$

$$\therefore \gamma = \frac{rg}{2} (h\rho - h_1\rho_1)$$

Thus  $\gamma$  can be determined from the values of  $r$ ,  $g$ ,  $h$ ,  $h_1$ ,  $\rho$  and  $\rho_1$

From fig. 19.19 (i), a capillary tube A is connected to a vessel W containing a funnel C, so that air is driven slowly through A when water enters W through C. Capillary tube A is placed inside a beaker containing liquid L. When air is passed through it at a slow rate, a bubble forms a slowly at the end of A.

Fig. 19.19 (ii) shows the bubble at three possible stages of growth. The radius grows from a to b. The pressure is larger at a since the radius is smaller when it grows to c, the radius of c is greater than b. Hence it cannot contain the increasing pressure.

The downward force of the bubble due to the pressure, in fact, would be greater than the upward force due to the surface tension. Hence the bubble becomes unstable and breaks away from A when its radius is the same as A.

Thus as the bubble grows, the pressure in it grows to maximum and then breaks away. This maximum pressure is observed from a manometer  $M$  containing a light oil of density  $\rho$ . A series of observations are taken as several bubbles grow.

$$\text{Maximum pressure inside bubble} = H + h\rho g$$

Where,  $h$  = maximum difference in levels in manometer  $M$

$H$  = atmospheric pressure

$$\text{Pressure outside the bubble} = H + h_1\rho_1 g$$

Where,  $h_1$  = depth of orifice of A below the level of liquid L

$\rho_1$  = density of liquid L

$$\text{Excess pressure} = (H + h\rho g) - (H + h_1\rho_1 g) = h\rho g - h_1\rho_1 g = \frac{2\gamma}{r}$$

$$\therefore \frac{2\gamma}{r} = g(h\rho + h_1\rho_1 g)$$

$$\therefore \frac{2\gamma}{r} = \frac{rg}{2} (h\rho - h_1\rho_1 g) \dots\dots\dots (19.16)$$

By adding warm liquid to the vessel containing L. the variation of the surface tension with temperature can be determined.

In conclusion, it can be established that the surface tension of the liquid decreases as the temperature increases. There has been no satisfactory formula to relate surface tension with temperature. An explanation about this observation is that the decrease in surface tension with temperature may be attributed to greater separation of molecules at higher temperatures. Force of attraction is thus reduced; hence, the surface tension is reduced.

### 3.8 Surface Tension and Surface Energy

So far we have defined surface tension of a liquid as a force per unit length where force are present in a system, there may also be energy.

For example, energy exists in gravitational fields. The problem we wish to look into in this section is to see if we can define surface tension in terms of surface energy. We shall now consider the surface energy of a liquid and its relationship to its surface tension  $\gamma$ .

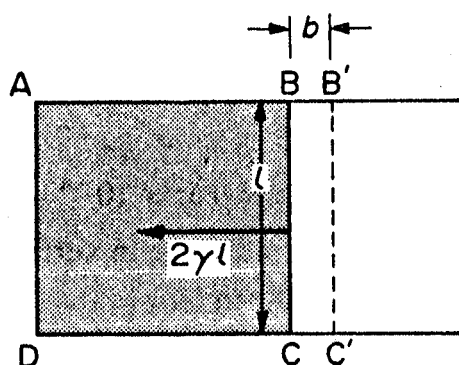


Fig. 19.20: Surface Tension & Surface Energy

Consider a film liquid stretched across a horizontal frame ABCD (fig. 19.20). Since  $\gamma$  is the force per unit length the force on the rod BC of length  $l = \gamma \times 2l$ .

The length is  $2l$  because there are two soap film surfaces in contact with air. Suppose the rod is now moved through a distance  $b$  from BC to B'C' against the surface tension forces, so that the surface area of the film increases. The temperature of the film then usually decreases in which case the surface tension alters. If the surface area increases under isothermal condition (isothermal means constant temperature) however, the surface tension is constant we can then say that if  $\gamma$  is the surface tension at that temperature:



$$\begin{aligned} \text{Work done in enlarging the surface area (W)} &= \text{force} \times \text{distance} \\ &= 2 \gamma \ell \times b \\ &= \gamma \times 2 \ell b \end{aligned}$$

But  $2 \ell b$  is the total increase in the surface area.

$$\begin{aligned} \therefore \frac{\text{Work done in enlarging the area}}{a} &= \gamma \\ \frac{W}{2 \ell b} &= \gamma \\ \frac{W}{A} &= \gamma \dots\dots\dots (19.17) \end{aligned}$$

Thus  $\gamma$  is defined as the work done in increasing the surface area by unit amount provided there is no temperature change of the surface as the change is made. That is the change is isothermal.

This is also called the free surface energy because the mechanical work done can be released when the surface contracts. Thus ***“ $\gamma$  can be defined as the work done per unit area in increasing the surface area of a liquid under isothermal conditions”***.

If the film temperature fell while the area was increased heat would flow into the film. The increase in total energy of the area would then be greater than  $\gamma$ .

### SELF ASSESSMENT EXERCISE 5

A soap bubble of radius 3cm is blown under isothermal conditions from

- (a) A soap film of very small area and
- (b) A bubble of radius 2cm. Determine the work in each case (surface tension of a soap solution =  $3.0 \times 10^{-2} \text{Nm}^{-1}$ ).

### 4.0 CONCLUSION

The surface tension is a property of a liquid. It is a surface phenomenon of liquids, which explain why their surfaces act as skin, a boundary made up of surface molecules having a resultant force towards the bulk of the liquid. The surface tension explains then formation and shapes of the meniscus of a liquid inside a tube. It has been used to explain why some liquids wet and do not wet glass through the concepts of adhesive and cohesive forces of liquids and that of the glass in which the liquids

are placed. Furthermore, surface tension explains the rise and fall of liquids in capillary tubes and the formation of bubbles in liquids and in air. The coefficient of surface tension is defined as the force per unit length. The surface tension of a liquid decreases with temperature. The surface tension of a liquid is also defined in terms of the work done in extending the surface area of a liquid.

Finally, a method to determine the  $\gamma$  of a liquid has been described.

## 5.0 SUMMARY

In this unit you have learnt the following:

- Surface tension is a surface phenomenon in liquids;
- The coefficient of surface tension  $\gamma$  is defined as the force per unit length acting normally on one side of a line on the surface;
- The angle of contact for clean water and clean glass is zero;
- Adhesive force between glass and water molecules is greater than the cohesive force between water molecules;
- The angle of contact is obtuse for mercury and glass;
- The excess pressure  $\rho$  for curved liquid surface

$$\rho = \frac{2\gamma \cos \theta}{r}$$

- The excess pressure for bubble in water  $\rho = \frac{2\gamma}{r}$
- With connected soap bubbles air passes from the small radius as the large bubble;
- When water rises to the top of a short capillary tube it does not overflow but forms a meniscus at the top which has an acute angle of contact;
- Surface energy is defined in terms of the coefficient of surface tension  $\gamma$ ;
- Surface energy is the work done in increasing the surface area by unit amount under constant temperature (isothermal) condition.

## ANSWER TO SELF ASSESSMENT EXERCISE 1

Refer to Text.

**ANSWER TO SELF ASSESSMENT EXERCISE 2**

$$\text{Excess pressure } P = \frac{4\gamma}{r}$$

$$P = \frac{4 \times 25 \times 10^{-3} \text{ Nm}^{-1}}{0.5 \times 10^{-2} \text{ m}} = 20 \text{ Nm}^{-2}$$

$$\text{The excess Pressure} = 20 \text{ Nm}^{-2}$$

**ANSWER TO SELF ASSESSMENT EXERCISE 3**

$$\cos \theta = \frac{r}{R} = \frac{h_1}{h}$$

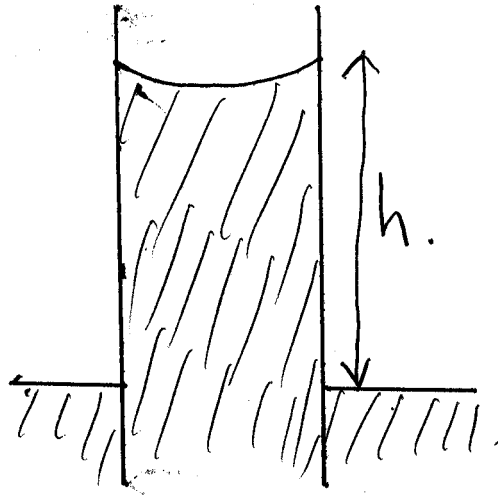
$$\therefore \cos \theta = \frac{4}{8} = 0.5$$

$$\therefore \cos^{-1} 0.5 = 60^\circ$$

The angle of contact of liquid is  $60^\circ$ .

**ANSWER TO SELF ASSESSMENT EXERCISE 4**

(a)



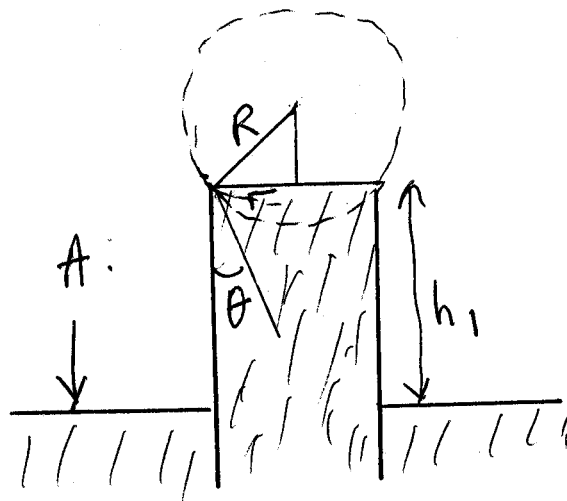
**Fig. 19.21**

$$\text{As you know } \frac{2\gamma}{r\rho g} = h$$

Now substituting the values, we get

$$\begin{aligned}
 &= \frac{2 \times 7.2 \times 10^{-2} \frac{\text{N}}{\text{m}}}{2 \times 10^{-4} \text{m} \times 1000 \frac{\text{kg}}{\text{m}^3} \times 10 \frac{\text{m}}{\text{s}^2}} \\
 &= \frac{2 \times 7.2 \times 10^{-2}}{2 \times 10^{-4} \times 1000 \times 10} \text{m} \\
 &= 7.2 \times 10^{-2} \text{m} \\
 h &= 7.2 \text{cm}
 \end{aligned}$$

- (b) When the tube is pushed down so that its top is 4cm above the water level outside the water does not overflow. It remains at the top with an acute angle of contact  $\theta$  and a new radius of curvature  $R$ .



**Fig. 19.22**

In this case, the excess pressure above the curved liquid is

$$\begin{aligned}
 \frac{2\gamma}{R} &= H - (H - h_1 \rho g) \\
 \therefore \frac{2\gamma}{R} &= h_1 \rho g
 \end{aligned}$$

$$\text{But, } \frac{2\gamma}{r} = h \rho g$$

$$\text{Where, } r = 2 \times 10^{-4} \text{m}$$

$$h = 7.2 \text{cm}$$

$$\therefore \frac{r}{R} = \frac{h_1}{h} = \frac{4}{7.2} = \cos\theta$$

$$\therefore \cos\theta = \frac{4}{7.2} = 0.5556$$

$$\therefore \theta = \cos^{-1}0.5556$$

$$\therefore \theta = 56^\circ$$

$$\frac{2 \times 10^{-4}}{R} = \frac{4}{7.2}$$

$$\therefore R = \frac{7.2 \times 10^{-4} \times 2}{4} = 3.6 \times 10^{-4} \text{m}$$

### ANSWER TO SELF ASSESSMENT EXERCISE 5

The gain in surface tension = The gain in surface tension =  $\gamma$  x increase in surface area

(a) The area of a sphere =  $4\pi r^2$

Since the soap bubble has two surfaces with air

$$\begin{aligned} \text{Increase in surface energy} &= \gamma \times 4\pi r^2 \times 2 \\ &= 3 \times 10^{-2} \text{N/m} \times 8\pi \times 9 \times 10^{-6} \text{J} \\ &= 3 \times 8\pi \times 9 \times 10^{-6} \text{J} \\ &= 68.58 \times 10^{-6} \text{J} \\ &= 6.79 \times 10^{-4} \text{J} \end{aligned}$$

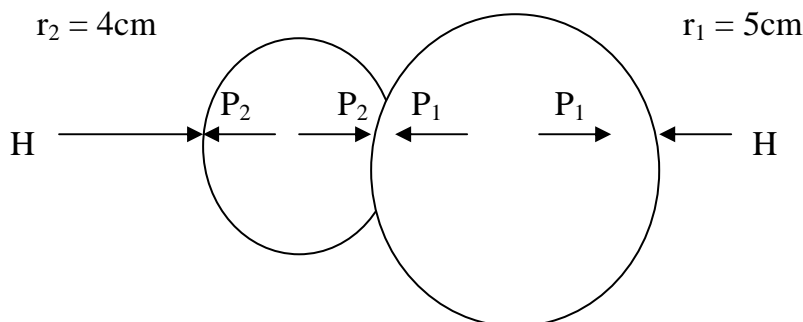
Work done =  $6.79 \times 10^{-4} \text{J}$

(b) In this case energy increase =  $\gamma \times 8\pi(r_1^2 - r_2^2)$

$$\begin{aligned} &= 3 \times 10^{-2} \frac{4}{7.2} 8\pi(r_3^2 - r_2^2) \times 10^{-4} \text{m}^2 \\ &= 10^{-4} \text{J} \\ &= \text{Work Done} \end{aligned}$$

## 6.0 TUTOR-MARKED ASSIGNMENT

1.



**Fig. 19.1**

In fig. 1.1 above are two connected soap bubbles of radii 4cm and 5cm respectively, which have a soap film of radius  $r$  between them. Calculate the radius of  $r$ .

2. In the experiment to determine the coefficient of surface tension  $\gamma$  for water, using the capillary rise of water, the following values were obtained:

$$r = 0.2\text{mm}, h = 6.6\text{cm}, g = 9.8\text{m/s}^2, \rho = 1000\text{kg/m}^3$$

Calculate the coefficient of surface tension.

3. In the experiment of determining the coefficient of surface tension using the microscope slide method, mass of slide was found to be 0.88g,  $a = 6.0\text{cm}$ ,  $b = 0.2\text{cm}$ ,  $g = 9.8\text{m/s}^2$ . what value of  $\gamma$  do these data give?

## 7.0 REFERENCES/FURTHER READING

Awe, O. and Okunola, O. O. (1986). *Comprehensive Certificate Physics*, Ibadan: University Press.

Ference, M. (Jnr.), Lemon, H.B. and Stephenson, R. J. (1970). *Analytical Experimental Physics*, Chicago: The University of Chicago Press.

Feynman, R. P., Leighton, R. B. and Sands, M. (1971). *The Feynman Lectures on Physics*, California: Addison – Wesley Publishing Company Limited.

Flowers, B. H. and Mendoza, E. (1970). *Properties of Matter*, London: John Wiley and Sons Limited.

Noaks, M. A. (1963). *New Intermediate Physics*, Canada: Macmillan and company Limited.

Soars, F. W., Zemansky, M.W. and Young, H. D. (1980). *College Physics Addison* – London: Wesley Publishing Company.

Tyler, F. (1966). *Heat and Thermodynamics*. London: Edwards Arnold Publisher Limited.

Wilkinson, J. (1983). *Essentials of Physics*, Australia: Macmillan Education Publishers.

Zemansky, M.W. (1968). *Heat and Thermodynamics*. New York: McGraw-Hill Book Company.

## UNIT 5 OTHER PROPERTIES OF GASES

### CONTENTS

- 1.0 Introduction
- 2.0 Objectives
- 3.0 Main Content
  - 3.1 Dalton's Law of Partial Pressure
    - 3.1.1 Definition of Dalton's Law
    - 3.1.2 Proof of Dalton's Law
  - 3.2 Graham's Law of Diffusion of Gases
    - 3.2.1 Graham's Law
  - 3.3 Avogadro's Law
- 4.0 Conclusion
- 5.0 Summary
- 6.0 Tutor-Marked Assignment
- 7.0 References/Further Reading

### 1.0 INTRODUCTION

We have discussed so far Boyle's law, Charles's Law and the pressure law in understanding the behaviour of gases. There are other laws that also describe the behaviour of gases. These are the Dalton's law of partial pressure, Graham's law of diffusion of gases and Avogadro's law. These laws are equally important in the study of both physics and chemistry. This unit has therefore been focused to discuss these other laws that show the characteristics behaviour of gases.

### 2.0 OBJECTIVES

At the end of this unit, you should be able to:

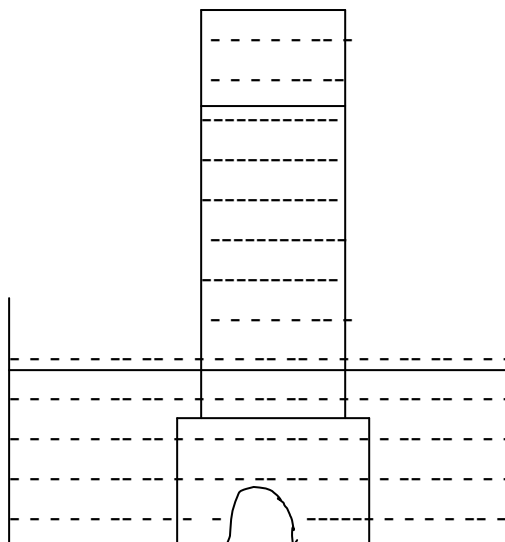
- state Dalton's law of partial pressure
- state Graham's law of diffusion of gases
- state Avogadro's laws
- solve problems based on these laws.

### 3.0 MAIN CONTENT

#### 3.1 Dalton's Law of Partial Pressure

A closed vessel may contain a mixture of gases. For example when a gas is being prepared and collected over water, as shown in fig. 20.1, the space in the gas jar will contain not only the gas being collected but also some water vapour.





**Fig: 20.1**

A closed vessel with some water inside it may also contain a mixture of air and saturated water vapour. That is, there is an equilibrium between the vapour phase and the liquid phase.

Dalton's law of partial pressure describes the pressures of the two gases in a container.

Thus, in the study of chemistry, when a gas is being prepared and collected over water, there is a situation whereby the gas exerts its own pressure while the saturated water vapour pressure also plays a part.

### 3.1.1 Definition of Dalton's Law

Dalton's law of partial pressure states that;

“In a mixture of gases, the total pressure is the sum of the pressures of the parts or individual gases each gas occupying the volume of the mixture e provided the gases do not reach chemically with one another”.

When we have a mixture of air and water vapour, we usually apply the gas laws to the air. We do not apply the laws to water vapour. This is because the mass of water vapour may alter through the condensation as it occurs when the temperature falls. We therefore cannot apply the gas laws where there are changes in pressure and temperature.

### 3.1.2 Proof of Dalton’s Law

Consider a volume V containing

- $n_1$  molecules of gas each of mass  $m_1$ , mean square velocity  $\overline{c_1^2}$ , and exerting a pressure of  $P_1$ .
- $n_2$  molecules of another gas each of mass  $m_2$ , mean square velocity of  $\overline{c_2^2}$  and exerting a pressure  $P_2$ .
- $n_3$  molecules of yet another gas of mass  $m_3$ , with a mean square velocity  $\overline{c_3^2}$  exerting a pressure of  $P_3$ .

Let the whole mass be at the same temperature. Each gas will expand and fill up the whole volume of the container. Each gas will therefore occupy a volume V and will exert its own pressure.

From Kinetic theory of gases, we then obtain the following expressions for the gases:

- $P_1V = \frac{1}{3} n_1 m_1 \overline{c_1^2} = \frac{2}{3} n_1 \left( \frac{1}{2} m_1 \overline{c_1^2} \right) \dots\dots\dots (20.1)$

- $P_2V = \frac{1}{3} n_2 m_2 \overline{c_2^2} = \frac{2}{3} n_2 \left( \frac{1}{2} m_2 \overline{c_2^2} \right) \dots\dots\dots (20.2)$

- $P_3V = \frac{1}{3} n_3 m_3 \overline{c_3^2} = \frac{2}{3} n_3 \left( \frac{1}{2} m_3 \overline{c_3^2} \right) \dots\dots\dots (20.3)$

Since the gases are at the same temperature, the average kinetic energy of the molecules of each kind of gas will therefore be the same.

That is,

$$\frac{1}{2} m_1 \overline{c_1^2} = \frac{1}{2} m_2 \overline{c_2^2} = \frac{1}{2} m_3 \overline{c_3^2} = \overline{KE} = m \overline{c^2} \dots\dots\dots (20.4)$$

the average kinetic energy of the gas molecules. Adding the equations (20.1), (20.2), and (20.3) we then obtain

$$\therefore (P_1 + P_2 + P_3)V = \frac{1}{2} (n_1 + n_2 + n_3) \frac{1}{2} m \overline{c^2} \dots\dots\dots (20.5)$$

But  $n_1 + n_2 + n_3$  is the total number of molecules n, and the total pressure  $P_T$  can be expressed as,

$$P_T V = \frac{3}{2} n \frac{1}{2} m \overline{c^2} = \frac{1}{3} n m \overline{c^2} \dots\dots\dots (20.6)$$

$$\therefore (P_1 + P_2 + P_3)V = \frac{1}{3}(n_1+n_2+n_3)m\overline{c^2} = P_T V = \frac{1}{3}nm\overline{c^2} \dots\dots\dots (20.7)$$

$$\therefore P_T = P_1 + P_2 + P_3 \dots\dots\dots (20.8)$$

Thus the total pressure due to a mixture of gases or vapours, which do not interact in any way, is equal to the sum of their partial pressure. This is the Dalton’s law of partial pressure.

### 3.2 Graham’s Law of Diffusion of Gases

We have observed that gases are always in random motion. They move from region of high concentration to region of low concentration until a state of equilibrium is reached.

Gases also been observed to move or pass through porous membranes or pots. The movement from region of higher concentration to low region of concentration is what is described as diffusion.

Graham established the law that governs the diffusion of gases as they pass through porous membranes or porous pots.

#### 3.2.1 Graham’s Law

Graham’s law of diffusion of gases states that “*the rates of diffusion of gases through a porous membrane or pot under given conditions are inversely proportional to the square roots of their densities*”.

From Kinetic theory of gases, we know that

$$PV = \frac{1}{3}nm\overline{c^2} \dots\dots\dots (20.9)$$

On rearranging this expression, we get

$$\therefore \overline{c^2} = \frac{3PV}{nm} \dots\dots\dots (20.10)$$

Where,  $\overline{c^2}$  = mean square velocity of gas

P = pressure of the gas

V = volume of the gas

n = number of molecules

m = mass of each molecule

$\therefore nm = M =$  total mass of gas

Or in another form, it can be written as

$$\therefore \overline{c^2} = 3P \times \frac{V}{nm} = 3P \times \frac{V}{M} \dots\dots\dots (20.11)$$

But we know that

$$\frac{\text{mass}}{\text{volume}} = \text{density of gas}$$

$$\therefore \frac{M}{V} = \rho$$

Therefore,

$$\therefore \frac{M}{V} = \frac{1}{\rho} \dots\dots\dots (20.12)$$

Substituting Eq. (20.12) in the Eq. (20.11), we get

$$\text{Hence, } \overline{c^2} = \frac{3P}{\rho}$$

$$\therefore \overline{c} = \text{the average velocity of gas} = \sqrt{\frac{3P}{\rho}} \dots\dots\dots (20.13)$$

$$\therefore \overline{c} \propto \sqrt{\frac{1}{\rho}}$$

$$\overline{c} \propto \sqrt{\frac{1}{\rho}} \dots\dots\dots (20.14)$$

Thus if we have two gases at the same pressure P, and their densities (P<sub>1</sub> and P<sub>2</sub> and average mean square velocities  $\overline{c_1^2}$  and  $\overline{c_2^2}$  respectively, then

$$\sqrt{\overline{c_1^2}} = \sqrt{\frac{3P}{\rho_1}} \text{ and}$$

$$\sqrt{\overline{c_2^2}} = \sqrt{\frac{3P}{\rho_2}}$$

On dividing these Eqs. We obtain

$$\therefore \frac{\sqrt{\overline{c_1^2}}}{\sqrt{\overline{c_2^2}}} = \sqrt{\frac{3P}{\rho_1}} \div \sqrt{\frac{3P}{\rho_2}}$$

$$\begin{aligned}
 &= \sqrt{\frac{3P}{\rho_1}} \times \sqrt{\frac{\rho_2}{3P}} \\
 \therefore \frac{c_1}{c_2} &= \sqrt{\frac{\rho_2}{\rho_1}} \dots\dots\dots (20.15)
 \end{aligned}$$

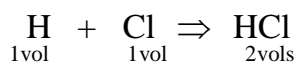
### SELF ASSESSMENT EXERCISE

100cm<sup>3</sup> of a gas A diffuses in 12 seconds and 100cm<sup>3</sup> of a gas B diffused in 40 seconds. Calculate the rates of diffusion of two gases.

### 3.3 Avogadro's Law

Avogadro's law has been very useful in chemistry. For example, it enables chemists to deduce the fact that some gases such as oxygen, hydrogen and chlorine are diatomic. Chemists were able to use the volumes of reacting gases to deduce the number of molecules involved in the chemical reaction.

For example experiments have shown that one volume of hydrogen will react with one volume of chlorine to produce two volumes of hydrogen chloride.



With Avogadro's law we can say that,

1 molecule of Hydrogen will react with 1 molecule of Chlorine to produces 2 molecules of Hydrogen Chloride. To produce 2 molecules of HCl implies that 1 molecule of Hydrogen will be H<sub>2</sub> while one molecule of Chlorine will be Cl<sub>2</sub>. That is, both Hydrogen and Chlorine are diatomic.

Avogadro's law states that,

“Equal volumes of all gases under the same conditions such as temperature and pressure contain equal numbers of molecules”

Let us consider two equal volumes V of two gases at the same pressure and same temperature. Same temperature means that  $\frac{1}{2} m \overline{c^2}$ , the average molecular kinetic energy is the same in both cases.

Suppose there are  $n_1$  molecules of mass  $m_1$  of one gas and  $n_2$  molecules of mass  $m_2$  in the other. Let their mean square velocities be  $\overline{c_1^2}$  and  $\overline{c_2^2}$ . From kinetic theory of gases, we can write

$$PV = \frac{1}{3} n_1 m_1 \overline{c_1^2} \text{ for the first gas ..... (20.16)}$$

$$\text{and } \frac{1}{3} n_2 m_2 \overline{c_2^2} \text{ for the second gas ..... (20.17)}$$

Since P and V are the same for both gases then

$$\frac{1}{3} n_1 m_1 \overline{c_1^2} = \frac{1}{3} n_2 m_2 \overline{c_2^2} \text{ ..... (20.18)}$$

Multiply and divide both sides of the Eq. (20.18), by 2 then we will obtain

$$\begin{aligned} \frac{2}{3} \frac{1}{2} n_1 m_1 \overline{c_1^2} &= \frac{2}{3} \frac{1}{2} n_2 m_2 \overline{c_2^2} \\ \therefore \frac{1}{2} n_1 m_1 \overline{c_1^2} &= \frac{1}{2} n_2 m_2 \overline{c_2^2} \\ \therefore n_1 \times \frac{1}{2} m_1 \overline{c_1^2} &= n_2 \times \frac{1}{2} m_2 \overline{c_2^2} \text{ ..... (20.19)} \end{aligned}$$

But  $\frac{1}{2} m_1 \overline{c_1^2} = \frac{1}{2} m_2 \overline{c_2^2}$  energy of the molecules since the temperature of the gases is the same.

$$\therefore n_1 = n_2 \text{ ..... (20.20)}$$

Here, the two gases contain the same number of molecules.

#### 4.0 CONCLUSION

In this unit we have learnt Dalton’s law partial pressure of two or more gases, Graham’s law of diffusion of gases through porous membranes or pots and Avogadro’s law of combining volumes of gases, as they affect the behaviour of gases. We have also been able to validate or prove these laws by using the molecular kinetic theory of gases.

## 5.0 SUMMARY

In this unit you have learnt

- The Dalton's law of partial pressure which enables us to determine the pressure of gases contained in a given volume.
- For Dalton's law
 
$$P_{\text{TOTAL}} = P_1 + P_2 + P_3 + \dots\dots\dots$$
- The Graham's law of diffusion of gases states that the rate of diffusion of a gas is inversely proportional to the relative density of the gas or its relative molecular mass.
- Avogadro's law of combining gases, which states that equal volume of gases under the same conditions such as pressure and temperature, contain equal numbers of molecules.

### ANSWER TO SELF ASSESSMENT EXERCISE

$$\begin{aligned} \text{Rate of diffusion of A} &= \frac{V}{t} \\ &= \frac{100\text{cm}^3}{12\text{s}} \\ &= 8.3 \frac{\text{cm}^3}{\text{s}} \end{aligned}$$

$$\begin{aligned} \text{Rate of diffusion of B} &= \frac{V}{t} \\ &= \frac{100\text{cm}^3}{40\text{s}} \\ &= 2.5 \frac{\text{cm}^3}{\text{s}} \end{aligned}$$

## 6.0 TUTOR-MARKED ASSIGNMENT

1. A closed vessel contains a mixture of air and water vapour at  $27^\circ\text{C}$  and the total pressure is  $1.06 \times 10^5\text{Pa}$ . At this temperature the water is just saturated. If the temperature is raised to  $87^\circ\text{C}$  calculate the air pressure and the water vapour pressure.

(S.V.P. of water at  $27^\circ\text{C} = 0.04 \times 10^5\text{Pa}$ , S.V.P. of water at  $17^\circ\text{C} = 0.02 \times 10^5\text{Pa}$ ).

2. As in question 1, if the temperature is now lowered to  $17^\circ\text{C}$ . What is now the total pressure of the systems?

(S.V.P. of water at  $27^{\circ}\text{C} = 0.04 \times 10^5\text{Pa}$ , S.V.P. of water at  $17^{\circ}\text{C} = 0.02 \times 10^5\text{Pa}$ ).

3. Oxygen diffused at the rate of  $4\text{cm}^3\text{s}^{-1}$ . Calculate the rate of diffusion of methane under the same condition.

## 7.0 REFERENCES/FURTHER READING

Awe, O. and Okunola, O. O. (1986). *Comprehensive Certificate Physics*, Ibadan: University Press.

Ference, M. (Jnr.), Lemon, H.B. and Stephenson, R. J. (1970). *Analytical Experimental Physics*, Chicago: The University of Chicago Press.

Feynman, R. P., Leighton, R. B. and Sands, M. (1971). *The Feynman Lectures on Physics*, California: Addison – Wesley Publishing Company Limited.

Flowers, B. H. and Mendoza, E. (1970). *Properties of Matter*, London: John Wiley and Sons Limited.

Noaks, M. A. (1963). *New Intermediate Physics*, Canada: Macmillan and company Limited.

Soars, F. W., Zemansky, M.W. and Young, H. D. (1980). *College Physics Addison – London: Wesley Publishing Company*.

Tyler, F. (1966). *Heat and Thermodynamics*. London: Edwards Arnold Publisher Limited.

Wilkinson, J. (1983). *Essentials of Physics*, Australia: Macmillan Education Publishers.

Zemansky, M.W. (1968). *Heat and Thermodynamics*. New York: McGraw-Hill Book Company.