



NATIONAL OPEN UNIVERSITY OF NIGERIA

SCHOOL OF SCIENCE AND TECHNOLOGY

COURSE CODE: AGR 205

**COURSE TITLE:
INTRODUCTION TO AGRO-CLIMATOLOGY**



**COURSE
GUIDE**

**AGR 205
INTRODUCTION TO AGRO-CLIMATOLOGY**

Course Team S. D. Musa Course (Developer/Writer) - Kogi State
University, Anyigba
Dr. T. E. Ologunorisa (Course Editor)
Professor A. Adebajo (Programme Leader) –
NOUN
Dr. N. E. Mundi (Course Coordinator) – NOUN

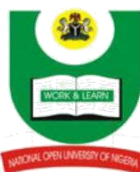

NATIONAL OPEN UNIVERSITY OF NIGERIA

National Open University of Nigeria
Headquarters
14/16 Ahmadu Bello Way
Victoria Island, Lagos

Abuja Office
5 Dar es Salaam Street
Off Aminu Kano Crescent
Wuse II, Abuja

e-mail: centralinfo@nou.edu.ng

URL: www.nou.edu.ng

Published by
National Open University of Nigeria

Printed 2008

Reprinted 2014

ISBN: 978-058-233-9

All Rights Reserved

CONTENTS	PAGE
Introduction.....	iv
What You will Learn in this Course	iv
Course Aim.....	v
Course Objectives.....	v
Working through this Course.....	vi
Course Material.....	vi
Study Units.....	vi
Text Books and References.....	viii
Assessment.....	viii
Tutor-Marked Assignment.....	ix
Final Examination and Grading.....	ix
Summary.....	ix

INTRODUCTION

The study of climatology is fundamentally concerned with the weather and climate of any given area. Essentially, environmental scientists are interested in the processes which take place in the atmosphere because the processes affect the various components of the environment. Climatology has made enormous contributions towards ensuring that we have a good understanding and control of these processes.

The weather of a place refers to the atmospheric condition at a given point in time. Climate on the other hand is the synthesis of the weather of a place over a period of about 35 years. Climatology refers to the scientific study of climate. It is closely related to meteorology which is the science of the physical, chemical and dynamic state of the atmosphere. However, meteorology deals with the study of the weather while climatology is concerned with the climate.

This course as it is conceived here has to do with the understanding of the knowledge of certain aspects of climatology which are relevant to agricultural practices. Essentially, we are talking of agro climatology as implying the use of climatological data in ensuring the practical and effective management of agriculture.

WHAT YOU WILL LEARN IN THIS COURSE

This course carries two credit units.

This course guide tells you briefly what to expect from reading this course material. The study of agro climatology may be described as the cross breeding of two disciplines, climatology and agriculture. The living components of the environment (particularly plants and livestock) respond in different ways to the atmospheric situations. It is these interactions between the atmospheric environment and the plants and livestock that constitute the major concern of agro climatology.

As mentioned earlier, climatology deals with the scientific study of climate that is the pattern of behaviours of the atmosphere over a long period of time. In terms of approach the study can be subdivided into regional climatology which is the description of climates over selected areas of the earth; synoptic climatology which relates the prevailing atmospheric condition to weather and climate; physical climatology which emphasises global energy and water balance regimes of the earth and the atmosphere amongst others.

Weather and climate being the focal point of climatology, the various components like rainfall, temperature, humidity, sunshine, wind amongst others will be examined. The controlling factors, altitude,

latitude, temperature, etc of the different elements together with dynamics of the earth's atmosphere will also be discussed.

Radiation, the incoming and outgoing solar energy, determines the temperature of the various places on earth. Atmospheric moisture is the level of wetness of the atmospheric air; it determines the humidity of the air. The differential heating of the earth's surface results in the spatial temperature variation of pressure which eventually determines the direction of movement of the wind.

The processes of rainfall starts with an uplift expansion of warm air until it reaches saturation point. It reaches the climax when condensation of water vapour results in precipitation.

The temperature, daylight, radiation, rainfall and evapotranspiration will vary with season. The fluctuations are attributable to change in atmospheric conditions with season.

Measurement of the various elements of climate is done using specialised equipment like the thermometer, rain gauges, wind vanes, anemometers, sunshine recorders among others. These equipment are kept in various positions in a standard meteorological station (where they are monitored for the various data) and are properly maintained.

The tropics have relatively higher temperatures than other parts of the world. The warm climates have peculiar implications for agriculture particularly as it affects crops, livestock, irrigation, pests and diseases.

COURSE AIM

The course aims to provide a good understanding of the climatic systems for a better management of agriculture.

COURSE OBJECTIVES

After going through this course, you should be able to:

- Explain the nature and scope of climatology
- Explain the elements and factors of weather and climate
- Explain the dynamics of the atmosphere
- Appreciate the dynamics of pressure and wind systems.
- Appreciate the seasonal variations in the different factors of the climate
- Identify the equipment used to measure the various elements of climate and state how to maintain them

Expressly state the relationship between climate and agriculture.

WORKING THROUGH THIS COURSE

This course has been carefully put together bearing in mind the fact that it is an introductory course. However, efforts have been made to ensure adequate explanation of the concepts and issues treated in the work. Diagrams and tables have been used where necessary to enhance your understanding. You are advised to spend good time to study the work and ensure that you attend tutorial sessions where you can ask questions and compare your knowledge with that of your classmates.

COURSE MATERIALS

You will be provided with the following materials:

A Course guide

Study Units.

In addition, the course comes with a list of recommended text books which are not compulsory for you to acquire or read, but are essential to give you more insight into the various topics discussed.

STUDY UNITS

The course is divided into 15 units. The following are the study units contained in this course:

Module 1

- Unit 1 The Principles, Aims and Scope
- Unit 2 Elements of Climate and Weather I
- Unit 3 Elements of Climate and Weather II
- Unit 4 Dynamics of Earth's Atmosphere
- Unit 5 Radiation and Heating of the Atmospheric System

Module 2

- Unit 1 Atmospheric Moisture
- Unit 2 The Dynamics of Pressure and Wind Systems
- Unit 3 Condensation and the Precipitation Process
- Unit 4 Seasonal Variations in Temperature Daylight, Radiation
- Unit 5 Seasonal Variation in Rainfall and Evaporation

Module 3

Unit 1	Equipment and Maintenance of a Standard Meteorological Station
Unit 2	Measurement of Air Pressure, Wind Speed, Wind Direction, Radiation and Sunshine Duration
Unit 3	Measurement of Evaporation and Evapotranspiration and the Maintenance of a Standard Meteorological Station
Unit 4	Climate and Agriculture in the Tropics I
Unit 5	Climate and Agriculture in the Tropics II

Module 1

In unit one you will be taken through the definition of weather and climate and the activities of man's influence on these two phenomena. You will also be taken through the meaning of climatology and how it differs from meteorology. In the next two units, you will be taken through the elements of weather and climate and their control factors. Temperature and solar radiation are focused in unit two while forms of precipitation and distribution of pressure and winds are discussed in unit three.

The dynamics of the earth's atmosphere constitute the major focus of unit four. You will be taken through the peculiarities of the atmospheric circulation systems including the general circulation and others.

The general principles involved in radiation and heating of the atmospheric system form the theme of unit five. You will be taken through the form and nature of solar radiation and how the atmosphere is heated up by terrestrial radiation.

Module 2

In unit one, you will be taken through the source of the moisture in the atmosphere. Also you will be introduced to the knowledge of the amount and distribution of atmospheric moisture. Unit two will introduce you to the dynamics of pressure and wind systems. You will also learn about the various belts of permanently low and high pressure and the global wind system.

The processes of condensation and precipitation will be introduced to you in unit three. You will also be taken through the formation and types of precipitation.

In unit four, you will be introduced to the seasonal variations in radiation, daylight and temperature. Again you will learn about the

factors responsible for these variations, particularly from one latitude to the other.

Unit five again introduces you to seasonal variations as they affect evaporation and rainfall. You will also learn about the major factors controlling the climate of West Africa which is the Inter Tropical Discontinuity (ITD)

Module 3

In unit one, you will learn about the categories of weather stations and the measurement of elements like rainfall, air temperature and humidity. You will be exposed to the instruments and procedures of measuring air pressure, wind speed, wind direction, radiation and sunshine duration in unit two.

In unit three, you will learn about evapotranspiration. Also you will be taken through how to maintain a standard meteorological station.

Unit four introduces you to the general effects of radiation, photo periodism, water and humidity on the growth of crops.

Unit five introduces you to the effects of temperature on crop growth. You will further learn about the relationship between agriculture and irrigation on one hand and agriculture and pests and diseases on the other. Finally, you will learn about the relationships between climate and livestock.

TEXT BOOKS AND REFERENCES

The following textbooks are recommended for further reading

Ayoade, J.O. (2004). *Introduction to Climatology for the Tropics*.
Ibadan: Spectrum Books Limited.

Ayoade, J.O. (2002). *Introduction to Agro Climatology*. Ibadan: Vantage Publishers.

Donald Ahren C. (1994). *Meteorology Today. An Introduction to Weather, Climate and the Environment* (5th ed). U.S.A: West Publishing Company.

Ojo, O. et al (2001) .*Fundamentals of Physical and Dynamic Climatology*
Lagos: SEDEC Publishers.

ASSESSMENT

There are two components of assessment for this course. They are the Tutor-Marked Assignment (TMA), and the end of course examination.

TUTOR-MARKED ASSIGNMENT

The TMA is the continuous assessment component of your course. It accounts for 30% of the total score. The TMAs will be given to you by your facilitator and you will return it after you have done the assignment.

FINAL EXAMINATION AND GRADING

This examination concludes the assessment for the course. It constitutes 70% of the whole course. You will be informed of the time for the examination.

SUMMARY

This course intends to provide you with the knowledge of weather and climate as it affects agricultural production. By the end of this course you will be able to answer the following questions.

- What is weather and climate and how do they affect the activities of man?
- Discuss the nature and scope of climatology.
- Discuss the radiation balance of the earth's atmospheric system.
- Describe and explain the general circulation of the atmosphere.
- Discuss the main theories of raindrop formation.
- Discuss the global distribution of pressure and wind.
- Describe the mode of formation of the convective, cyclonic and orographic precipitation.
- Comment about the importance of Inter Tropical Discontinuity.
- Describe the features of a standard meteorological station.
- Discuss the important steps to be adopted in the maintenance of meteorological stations.
- Explain the influence of solar radiation on crop growth and development.
- Explain the influences of temperature on crop production.

We wish you success in this course and hope that you will have a better understanding of the agro climatic phenomena in your environment.

Best of luck.



CONTENTS		PAGE
Module 1.....		1
Unit 1	The Principles, Aims and Scope.....	1
Unit 2	Elements of Climate and Weather I	6
Unit 3	Elements of Climate and Weather II.....	13
Unit 4	Dynamics of Earth’s Atmosphere.....	19
Unit 5	Radiation and Heating of the Atmospheric System.....	25
Module 2.....		31
Unit 1	Atmospheric Moisture.....	31
Unit 2	The Dynamics of Pressure and Wind System.....	37
Unit 3	Condensation and Precipitation Process.....	41
Unit 4	Seasonal Variations in Temperature Daylight, Radiation.....	48
Unit 5	Seasonal Variations in Rainfall and Evaporation.....	54
Module 3.....		60
Unit 1	Equipment and Maintenance of a Standard Meteorological Station.....	60
Unit 2	Measurement of Air Pressure, Wind Speed, Wind Direction, Radiation and Sunshine Duration.....	68
Unit 3	Measurement of Evaporation and Evapotranspiration and the Maintenance of a Standard Meteorological Station.....	76
Unit 4	Climate and Agriculture in the Tropics I.....	83
Unit 5	Climate and Agriculture in the Tropics II.....	89

MODULE 1

Unit 1	The Principles, Aims and Scope Elements
Unit 2	of Climate and Weather I Elements of
Unit 3	Climate and Weather II Dynamics of
Unit 4	Earth's Atmosphere Radiation and
Unit 5	Heating of the Atmospheric System

**UNIT 1 PRINCIPLES, AIMS AND SCOPE OF
CLIMATOLOGY**

CONTENTS

1.0	Introduction
2.0	Objectives
3.0	Main Content
	3.1 Weather and Climate
	3.2 Principles and Scope of Climatology
4.0	Conclusion
5.0	Summary
6.0	Tutor-Marked Assignment
7.0	References/Further Readings

1.0 INTRODUCTION

The various activities of man are influenced in numerous ways by the weather. The study of the weather (state of the atmosphere at a given time and place) is therefore as ancient as man's curiosity about his environment. The way man lives, the air he breathes, the food he eats and the water he drinks are all weather related. Weather phenomena was thought to be controlled by the gods until about 400 BC when Hippocrates and Aristotle published their works; *Air, Waters and Places*, and *Meteorological* respectively. The works represented the sum of knowledge on weather and climate at that time.

Traditional climatology is primarily concerned with describing the distribution pattern of weather elements over space and time within areas ranging in size from 1 or 2 km² to the whole earth. This descriptive approach to the study of weather and climate has several deficiencies which led to misconceptions about how atmospheric processes operate. Modern climatology has however tried to remove these deficiencies. Explanation and description of atmospheric phenomena is now being emphasised. Efforts are now being made to understand the processes and interactions taking place within the atmosphere and at the earth's

atmosphere interface. Modern climatology emerged from the challenges posed by the needs of society and the improvement in data collection and analysis. This unit examines the principles, aims and scope of climatology.

2.0 OBJECTIVES

At the end of this unit, you should be able to:

- define weather and climate
- define climatology
- understand the principles and aims of climatology
- understand the scope of climatology.

3.0 MAIN CONTENT

3.1 Weather and Climate

When we talk about weather, we refer to the state of the atmosphere at a given point in time at a given place. Weather is dynamic and has the elements of: air temperature, pressure, humidity, clouds, precipitation, visibility and wind. If we measure and observe these weather elements over a specified period of time, we would obtain the average weather or the climate of a particular place. Climate is therefore the accumulation of daily and seasonal weather events of a given location over a period of 30-35 years. The concept of climate is more than the average weather condition, it also includes weather events, considerations of variabilities (departure from averages), extreme conditions, and the probabilities of frequencies of occurrences of given weather conditions. In summary therefore, weather deals with the specific while climate deals with a generalisation of weather events. Weather and climate play a major role in our lives. Weather for example, often dictates the type of clothing we wear, while climate determines what types of crops can be planted and when to plant the crops. Weather determines if these same crops will grow to maturity. The most immediate effect of weather and climate is on our comfort. In order to survive the cold of winter and the heat of summer, we build our houses, heat them, cool them, only to find that when we leave our shelter we are at the mercy of the weather elements.

Even when we are properly dressed for the weather, wind, humidity and precipitation can change our perception of how cold or warm it feels. On a cold, windy day the effects of wind chill tell us that it feels much colder than it really is, and if not properly dressed, we run the risk of catching cold or developing catarrh. On a hot humid day we normally feel uncomfortably warm and blame it on the humidity of the weather. If

we become too warm our bodies overheat and heat exhaustion may result.

1. How does weather differ from climate?
2. Describe the role of weather and climate in our lives.

3.2 Principles and Scope of Climatology

Climatology is the scientific study of climate. It deals with the trend of weather over a long period of time. Essentially, climatology is an atmospheric science; though closely related but different from meteorology, it is the study of the atmosphere and its phenomena. The difference basically is in the methodology adopted. Whereas the meteorologist employs the laws of classical physics and mathematical techniques in the study of atmospheric processes, the climatologist relies on statistical techniques to derive information about climate from weather data. Like climatology, meteorology embraces both weather and climate but elements of meteorology must of necessity be incorporated into climatology to make the later meaningful and scientific.

The atmosphere is not only dynamic but also complex, as earlier mentioned, therefore the aim of climatology is to describe and explain the atmospheric phenomena with a view to promoting a better understanding of the processes and interactions within the atmosphere and between the atmosphere and the earth's surface.

Climatology has a wide scope and it can be subdivided either on the basis of the topics emphasised or on the scale of the atmospheric phenomena that are emphasised. Ayoade (2004) identified the six topical subdivision of climatology among others as follows:

1. Regional climatology: It is the description of climates over selected areas of the earth.
2. Synoptic climatology: It is the study of the weather and climate over an area in relation to the pattern of the pervading atmospheric circulation. Synoptic climatology is thus essentially a new approach to regional climatology.
3. Physical climatology: It involves investigating the behaviour of weather elements or processes in the atmosphere in terms of physical principles. Emphasis is on global energy and water balance regimes of the earth and the atmosphere.
4. Dynamic climatology: It places emphasis on the atmospheric motions on various scales, particularly the general circulation of the atmosphere.
5. Applied climatology: It is the application of climatological knowledge and principles to solving problems facing mankind.

6. Historical climatology: It is the study of the development of climate through time.

Several other subdivisions are recognised in the literature. These are, for instance, agricultural climatology, bioclimatology, building climatology, urban climatology, statistical climatology, etc. These subdivisions can however, be subsumed under one or more of the six subdivisions recognised above. Agricultural climatology, bioclimatology and building climatology are, for example, aspects of applied climatology.

An alternative approach to the subdivision of climatology is based on scales of meteorological motion systems (Table 1). It must be emphasised, however, that the various atmospheric phenomena ranging from planetary waves to local wind systems constitute a single continuous spectrum of weather systems. Using the scalar system in Table 1, the following three subdivisions of climatology can be recognised.

1. Macro climatology: It is concerned with features of climates of large areas of the earth and the large scale atmospheric motions that cause the climate;
2. Meso climatology: It is concerned with the study of climate over relatively small areas of between 10-100km across (e.g. the study of urban climate or severe local weather systems like tornadoes and thunderstorms); and
3. Microclimatology: It is concerned with the study of the climate close to the ground’s surface or very small areas less than 100 metres across.

Table 1: Scales of meteorological motion systems

Motion system	Horizontal scale (km)	Vertical scale (km)	Time scale (hours)
Macro			
1. Planetary waves	5×10^3	10	2×10^3 to
2. Synoptic	5×10^2 to	10	4×10^2
Perturbations	2×10^3	1-10	10^{-2}
Meso scale Phenomena	$1 - 10^2$	Less than	1-10
Micro scale Phenomena	Less than 10^{-1}	10^{-2}	$10^{-2} - 10^{-1}$

(Source: Ayode, 2004)

1. Define climatology. How is it different from meteorology?
2. Explain the scope of climatology.

4.0 CONCLUSION

The study of climatology is essentially hinged on the knowledge of weather and climate, the processes which take place in the atmosphere at specified times and places.

5.0 SUMMARY

In this unit we have learnt that:

1. The activities of man are influenced by the weather;
2. Weather is the state of the atmosphere at a given time and place;
3. Climate is the average weather situation of a place over a period of 30-35 years;
3. Climatology is the scientific study of climate;
4. Meteorology is the study of the atmosphere and its phenomena;
5. Climatology has a wide scope and can be subdivided into regional, synoptic, physical, dynamic, applied and historical climatology among others.

6.0 TUTOR-MARKED ASSIGNMENT

Without the atmosphere there cannot be climatology. Discuss the above stated assertion.

7.0 REFERENCES/FURTHER READING

Ayoade, J.O. (2004). *Introduction to Climatology for the Tropics*. Ibadan: Spectrum Books Limited.

Donald Ahren C. (1994). *Meteorology Today: An Introduction to Weather, Climate and the Environment* (5th ed). U.S.A: West Publishing Company.

UNIT 2 ELEMENTS AND CONTROLS OF CLIMATE AND WEATHER: TEMPERATURE AND SOLAR RADIATION

CONTENTS

- 1.0 Introduction
- 2.0 Objectives
- 3.0 Main Content
 - 3.1 Temperature
 - 3.1.1 Factors Influencing Temperature
 - 3.1.2 Climatic Elements
 - 3.2 Solar Radiation
 - 3.2.1 Factors of Solar Radiation
- 4.0 Conclusion
- 5.0 Summary
- 6.0 Tutor-Marked Assignment
- 7.0 References/Further Readings

1.0 INTRODUCTION

As earlier mentioned, life is dependent on the atmosphere, and there would be no weather and climate without the atmosphere. To collect various data on climate certain elements are normally observed and measured using weather instruments. These elements include temperature, precipitation, pressure and winds, solar radiation, cloud cover and humidity. These elements and their spatial distribution are controlled by one or all the climatic factors (controls): latitude, altitude, continentality, ocean currents, insolation, prevailing winds, natural vegetation and soil. The characteristics of solar radiation and temperature and their control will be discussed in this unit.

2.0 OBJECTIVES

At the end of this unit, you should be able to:

- know the characteristics of the various climatic elements, particularly temperature and solar radiation
- understand the effects of climatic factors on the temperature and solar radiation and how some climatic elements influence other elements.

3.0 MAIN CONTENT

3.1 Temperature

The main source of the energy for the earth-atmosphere system is the solar radiation. It is absorbed by either the earth or the atmosphere and partly converted into sensible heat or other forms of energy. The degree of sensible heat generated represents what is known as temperature. Temperature is thus defined as the degree of hotness or coldness.

3.1.1 Factors Influencing Temperature

The main categories of factors influencing temperature characteristics of a particular surface are climatic elements acting as factors. Such elements include solar radiation, net radiation, evaporation, winds, humidity and cloud cover. Non-climatic elements include type of surface, latitude and continentality.

3.1.2 Climatic Elements

Solar and Net Radiation

Temperatures are substantially affected by the amount of solar or net radiation available on a particular surface. Temperatures are particularly higher during summer than during winter season because of the higher insolation received during summer. During a daily cycle, on a sunny day, temperatures are highest in the afternoons when values of solar radiation and consequently net radiation are highest.

Cloud Cover

Cloud cover is another climatic element that significantly influences the penetration of solar radiation. With cloud cover, the amount of solar energy received or absorbed at a particular surface is reduced. In turn this reduces temperatures at the surface making it lower than what would be if the skies were cloudless. This factor, for example in part accounts for the lower temperatures in the humid areas with a lot of clouds compared with the arid areas with little or no cloud cover. The effect of cloud cover however, also operates in reverse, since it serves to retain much of the heat that would otherwise be lost from the earth's surface by radiation from a particular surface throughout the day or night (Greenhouse effect). The effects of cloud cover lessen the diurnal temperature ranges by preventing high maxima by day and low minima by night. This is usually the situation in the humid areas of the tropical

rain forests of West Africa, compared with the arid areas such as in the Sahara Deserts where the ranges of temperatures are always high.

3.1.3 Non-Climatic Elements

Types of Surfaces

Various types of surfaces react differently to solar radiation incidence in terms of reflection, absorption, and transmission and this accounts for the variation in heating potentials.

Vegetation surface: Both the reflectivity and transmission coefficient affect the amount of solar radiation over vegetated surfaces and consequently the amount of sensible heat generated. Also, part of the heat is lost through evaporation and transpiration. Surfaces with high evapotranspiration heat more slowly than surfaces with less evapotranspiration.

Land and water surface: Although the heating properties of the many kinds of land and vegetated surfaces vary considerably, the greatest contrasts are those between land and water surfaces, which react so differently to solar radiation. The surfaces of relatively deep bodies of water heat and cool slowly compared with land surfaces. The most important reason for this slowness of temperature change is that in water, a highly mobile matter, redistribution of heat occurs mainly through turbulence. In contrast to this medium of heat distribution, heat in the solid earth is distributed by molecular heat conduction, and so proceeds by moving from particle to particle. In water, on the other hand ocean currents, waves, tides and conventional overturning systems help dispersed to absorbed solar energy throughout a large mass of water. Because there is no such mixing on land, and assuming that equal amount of energy fall on both surfaces, water surfaces would heat up more slowly and have lower temperatures than land surfaces.

Latitude: As a result of the earth's inclination, the midday sun is almost overhead within the tropics but the sun's rays reach the earth at an angle outside the tropics. Thus there is a decrease in temperature from the equatorial regions to the poles. This is illustrated in Figure 1. Band R1 falls vertically over the equatorial latitudes on surface E. Band R2 falls obliquely over the temperate latitudes on surface T. R1 travels through a shorter distance and its concentrated solar insolation heats up a smaller surface area; temperature is thus high. On the other hand, R2 travels through a longer distance and much of its heat is absorbed by clouds, water vapour and dust particles. Its oblique rays have to heat up a larger area; temperature is therefore low.

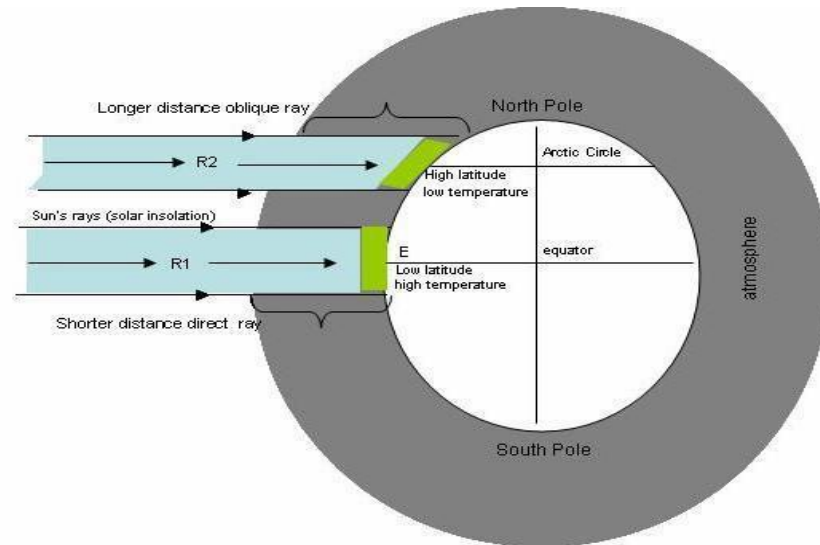

Figure 1: Varying distance in the distribution of

insolation Continentality (Distance from the Sea)

Continentality (or distance from the sea) is another factor which affects the characteristics of temperature in time and space. For example, near the ocean or water surface, daily temperature extremes are smaller than within the continental areas. Moreover, the variability of temperature is greater in areas far away from the sea than along the coastal areas. Thus maximum temperatures are higher and minimum temperatures are lower over continental climates than in oceanic or marine climates.

3.2 Solar Radiation

Life depends substantially on solar radiation because all physical and biological processes taking place on the earth's surface or in the atmosphere involve some form of energy transfer. Solar radiation is also a major requirement for other processes related to water, land, soil, vegetation and animals.

The sun provides over 99 per cent of the heat energy required for the physical processes taking place in the earth – the atmospheric system. As the sun radiates its energy, the amount received at the outer boundary of the earth's atmosphere, at normal incidence and at mean distance between the earth and the sun is known as the solar constant. The value of this constant is 2 langley(ly).

3.2.1 Factors of Solar Radiation

Solar Input

The solar constant, which is the basic amount of solar input, is a major factor of solar radiation received by the earth's surface, outside the atmosphere. In general the amount of solar radiation received outside the atmosphere also depends on a number of other factors, which include solar altitude and the duration of solar energy (length of day).

Solar Altitude

The altitude of the sun (angle between the rays of the sun and at tangent to the earth's surface at a point of observation) is an important factor which affects the amount of insolation received at the earth's surface. It depends on the time of the day, the latitude of the location and the time of the year (season). When the sun's altitude is great, the solar radiation intensity per unit area is highly concentrated at the earth's surface (Fig. 2). For example at noon, the intensity of insolation is greatest, but in the morning and evening hours when the sun is at a low angle, the amount of insolation is small. The same principle has a broader application with respect to latitude and the seasons. In winter and at high latitudes even the noon sun's angle is low. In summer and at low latitudes, it is more nearly vertical and the oblique rays of the low angle sun are spread over a greater surface than are vertical rays, thus less heating per unit areas is produced by the low-angle sun.

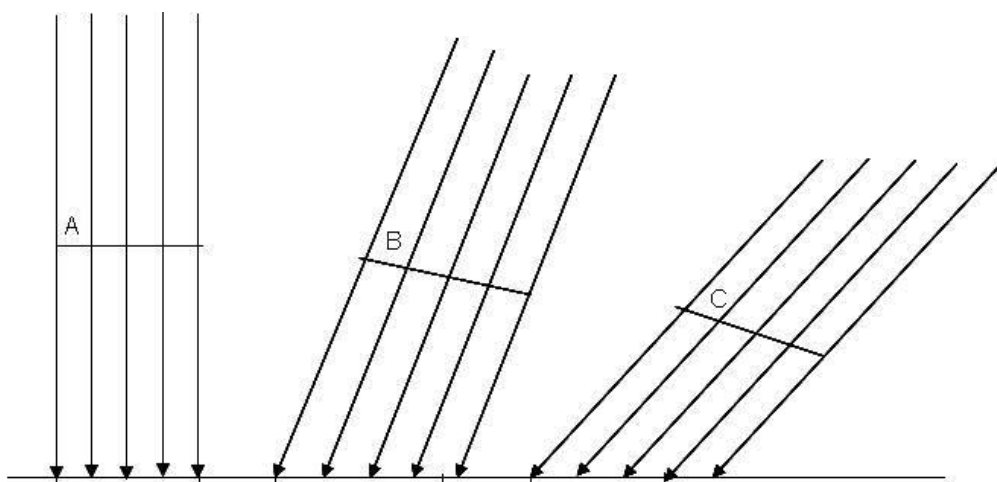

Fig. 2: Sun's Angle

The angle at which the solar radiation strikes the earth's surface however, also depends upon the surface configuration of the land. For example, in the middle and high latitudes of the northern hemisphere, southern slopes receive more direct rays while northern slopes may be

entirely in the shade. Also the possible hours of sunshine in a deep valley may be greatly reduced by surrounding hills.

The Length of Day

The longer the time of day during which the sun shines, the greater the quantity of radiation which a given portion of the earth will be able to receive. Table 2 shows the latitudinal variations of sunshine hours during the solstices and the equinoxes. Note that there are shorter days during winter solstice of every latitude to the north or south of the equator. During equinoxes the length of days and nights are equal for each latitude. Also note that there are six months of daylight hours during the summer solstice at the pole and zero hours of daylight hours (six months of darkness) during the winter solstice.

The variation in the length of day is as a result of the revolution of the earth around the sun and its rotation on its axis. Whereas the earth's rotation on its own axis causes day and night, its orbit round the sun explains the seasons. A complete rotation takes 24 hours resulting in the alternation of day and night, while a complete revolution takes 365 $\frac{1}{4}$ days at a variable speed which averages about 26km per second.

The effect of the atmosphere slightly affects the radiation received on the earth's surface. The atmosphere absorbs, reflects, scatters and re-radiates solar energy. Among the atmospheric constituents involved in the absorption are water vapour, liquid water carbon dioxide and ozone. Part of the incoming solar radiation is also scattered or reflected back to space. About 80% of the incoming solar radiations are reflected by clouds; clouds are powerful reflectors of shortwave radiation.

Table 2 Latitudinal variations of sunshine hours

Latitude	Winter Solstice	Vernal or Autumnal Equinox	Summer Solstice
90°	0	12 hours 0 min	6 months
80°	0	12 hours 0 min	4 months
70°	0	12 hours 0 min	2 months
60°	5 hours 33 min	12 hours 0 min	18 hours 27 min
50°	7 hours 42 min	12 hours 0 min	16 hours 18 min
40°	9 hours 8 min	12 hours 0 min	14 hours 52 min
30°	10 hours 4 min	12 hours 0 min	13 hours 56 min
20°	10 hours 48 min	12 hours 0 min	13 hours 12 min
10°	11 hours 25 min	12 hours 0 min	12 hours 38 min
0°	12 hours 0 min	12 hours 0 min	12 hours 0 min

(Source: Ojo, 1977)

4.0 CONCLUSION

The spatial distributions of climatic elements are not only affected by factors of climate but also by other climatic elements.

5.0 SUMMARY

In this unit, we have learnt that:

1. The main source of energy in the atmospheric system is solar radiation
2. Temperature, the degree of hotness or coldness, is influenced by climatic and non climatic elements.
3. Solar input, solar altitude and the length of day are some of the factors which affect solar radiation.

6.0 TUTOR-MARKED ASSIGNMENT

Explain the various factors influencing temperature as an element of climate.

7.0 REFERENCES/FURTHER READING

Areola, O. *et al* (1992). *Certificate Physical and Human Geography for Senior Secondary Schools*. Ibadan: University Press Plc.

Ojo, O. (1977). *The Climates of West Africa*. Ibadan: Heinemann Educational Books.

Ojo, O. *et al* (2001). *Fundamentals of Physical and Dynamic Climatology*. Sedec Publishers.

UNIT 3 ELEMENTS AND CONTROL OF CLIMATE AND WEATHER: PRECIPITATION AND PRESSURE AND WINDS

CONTENTS

- 1.0 Introduction
- 2.0 Objectives
- 3.0 Main Content
 - 3.1 Precipitation
 - 3.1.1 Forms of Condensation
 - 3.1.2 Forms of Precipitation
 - 3.2 Pressure and Winds
- 4.0 Conclusion
- 5.0 Summary
- 6.0 Tutor-Marked Assignment
- 7.0 References/Further Readings

1.0 INTRODUCTION

Precipitation, pressure and wind are some of the climatic elements that have substantial influence on weather and climate. They are equally affected by the climatic factors earlier mentioned.

2.0 OBJECTIVES

At the end of this unit, you should be able to:

- know the characteristics and forms of precipitation
- recognise the various forms of condensation and types of clouds
- define atmospheric pressure and wind.

3.0 MAIN CONTENT

3.1 Precipitation

Precipitation is usually in liquid or solid form. The common precipitation forms include rain, drizzle, snow, sleet and hail. They are always preceded by condensation or sublimation or a combination of the two. Let us now look at both forms of condensation and precipitation

3.1.1 Forms of Condensation

The maximum capacity of air for holding moisture may be reached if a parcel of air is cooled at constant pressure. Thus, the saturation point can

be reached at a particular temperature, even if the amount of the moisture content in it has not changed. Also the critical temperature at which saturation vapour pressure is reached is known as the dew point temperature, which may be defined as the temperature at which the quantity of water vapour in the air represents the maximum holding capacity of the air at that temperature.

Further cooling beyond dew point results in condensation either in form of water if temperature is above 0°C or, ice if it is below 0°C . Thus if the air is cooled below the dew point, then the excess of water vapour over what the air can hold at that temperature is given off in the form of water or ice. In this regard, condensation has taken place. The main forms of condensation include dew, frost, fogs and cloud.

Dew

Dew is commonly formed on clear calm nights when rapid radiation reduces the temperature of the air in contact with the ground. When this layer of air is cooled sufficiently but at a temperature above 0°C , condensation of water vapour occurs as dew on the ground.

Frost

Frost may be formed by a rapid radiation from ground surfaces at night when the dew point of the air is below 0°C . As a result the water vapour condenses as ice crystals on the surface in form of hoar frost. When warm moist air, from which light rain is falling passes over land surfaces with a temperature well below freezing point, glazed frost results. The rain, on reaching the very cold ground, immediately turns to ice.

Fog

Fog is the result of the condensation of water vapour near the ground (or over the sea) on to microscopic particles of dirt and dust in the air. Fog may be divided into two categories: (1) Radiation fog, (2) Advection fog.

Radiation Fog: This is a feature of winter the conditions necessary for the formation are cold weather with clear skies and calm conditions. The skies allow radiation of heat away from the earth into the atmosphere, thus cooling the air in contact with the ground. The calm conditions keep the air in contact with the ground long enough to allow it to be cooled sufficiently. The fog is formed when the air has been cooled to its dew point. The dirtier the air, the thicker the fog. Indeed industrial regions, with their smoky atmospheres, are known for their dense smoky fog (smog).

The warmth of the sun usually disperses the fog before midday, but if skies are overcast it may persist for days.

Advection Fog: The word advection implies a horizontal movement of air. If warm moist air passes over very cold land or over sea surfaces, then cooling of the lower layers of the warm air may result in condensation and the formation of fog. In West Africa, advection fogs are most common over the oceans, especially over cool currents. Sometimes, the term sea fog is used when fogs result from the movement of warm, moist air over such cold waters.

Clouds

Clouds are forms of condensation, formed when air is moved away from the land water surface. In particular, most clouds are condensation forms which have resulted from a lifting process away from the surface. Those associated with strong rising air currents have vertical development and a puffy appearance. Those resulting from a gentle lifting or other methods of cooling tend to spread into layers. Thus the method of their formation is largely accountable for their appearance. Clouds are classified on the basis of their height, general appearance and whether they are composed of water droplets or ice crystals. Four major cloud types and their variations can be recognised.

1. High Clouds: Mainly cirrus (ci) of feathery form at 6100-12,200m above ground.
 - a. Cirrus (ci). This looks fibrous and appears like wisps in the blue sky; it is often called “wares” tails. It indicates fair weather, and often gives a brilliant sunset.
 - b. Cirrocumulus (Cc). This appears as white globular masses, forming ripples in a “mackerel sky”.
 - c. Cirrostratus (Cs). This resembles a thin white sheet or veil; the sky looks milky and the sun or moon shines through it with a characteristic halo.

2. Middle Clouds: Mainly alto (Alt) or middle height clouds at 2100-6000m.
 - d. Altocumulus (Ac). These are wooly, bumpy clouds arranged in layers and appearing like waves in the blue sky. They normally indicate fine weather.
 - e. Alto stratus (As). These are denser, grayish clouds with a “watery” look. They have a fibrous or striated structure through which the sun’s rays shine faintly.

3. Low Clouds: Mainly stratus or sheet clouds below 2100m.
 - f. Stratocumulus (Sc). This is a rough, bumpy cloud with the waves more pronounced than in altocumulus. There is a great contrast between the bright and shaded parts.
 - g. Stratus (St). This is a very low cloud, uniformly grey and thick, which appears like a low ceiling or highland fog. It brings dull weather with a light drizzle. It reduces visibility of aircraft and is thus a danger.
 - h. Nimbo stratus (Ns). This is a dark dull cloud clearly layered and is also known as a “rain cloud”. It brings continuous rain, snow or sheet.

4. Clouds of Vertical Development: Mainly cumulus or heaps of clouds not limited to any definite height (6100-9000m).
 - i. Cumulus (Cu). This is a vertical cloud with a rounded top and horizontal base, typical of humid tropical regions, associated with up-rising convectional currents. Its great white globular masses may look grey against the sun but it is a fair weather cloud.
 - j. Cumulonimbus (Cb). These are heavy masses of clouds with great vertical developments, smooth or flattened at the top, and frequently anvil shaped. Thus their summits generally look like mountains or towers. They are normally accompanied by sharp showers, squally thunderstorms and sometimes hail.

3.1.2 Forms of Precipitation

The forms of precipitation include rain, drizzle, snow, sheet and hail.

Drizzle

Drizzle is a rather uniform precipitation of very numerous minute drops. It usually falls from fog, or thick layers of stratus.

Rain

Rain, which is the most common form of precipitation falls from rising air, when temperature at lower levels is above 0^oc. The droplets, as a rule are larger in size than drizzle. The maximum size to which a rain drop can grow is about 5mm in diameter though occasionally rain drops may be as small in size as the drizzle drops.

Snow

Snow is a precipitation of solid water mainly in the form of branched hexagonal crystals or stars. At temperatures not far from freezing point, they are usually malted together in large snows flakes.

Sleet

This is precipitation consisting of melting snow or a mixture of snow and rain. Snow and sleet may melt completely while falling through the air. They will then appear as rain on the ground.

Hail

Hail is a precipitation of balls or irregular lumps of ice of diameters ranging from 5-50mm or more. They are either transparent or composed of clear layers of ice alternating with opaque layers of snow-like structure. Hail falls almost exclusively in violent thunderstorms and is very rare at temperatures below freezing at the earth's surface.

3.2 Pressure and Winds

Pressure and winds are significant in climatology, first as elements of climate, but also very importantly as factors, especially of temperature and precipitation.

Atmospheric pressure can be defined as the weight exerted upon the earth by the atmosphere. The average air pressure at sea-level is around 1013 millibars but it varies slightly according to latitude. The air pressure decreases with altitude; at 4500 metres it is only 572 millibars. This is because at high altitude air is less dense.

Temperature also affects pressure because a rise in temperature causes the air to expand, reducing the air pressure. The reverse is the case when temperature falls, the air contracts and becomes denser, causing increase in air pressure.

There is a general variation in pressure over the earth's surface. Air flow is from areas of high pressure towards areas of low pressure. However, because of the earth's rotation, air flow is deflected. In the northern hemisphere it is deflected to the right; in the southern hemisphere it is deflected to the left.

4.0 CONCLUSION

Precipitation is preceded by condensation which occurs in various forms. Depending on temperature, precipitation may occur either in solid or liquid form. Pressure and wind also have significant effects on weather.

5.0 SUMMARY

In this unit we have learnt that:

1. Precipitation is in liquid or solid form depending on the temperature when it is formed
2. The process of condensation results in precipitation and there are different forms of condensation.
3. Pressure is the weight of atmospheric air exerted on the earth.
4. Air flow is from areas of high pressure to areas of low pressure and it is deflected to either left or right.

6.0 TUTOR-MARKED ASSIGNMENT

1. What is condensation and in what forms does it exist?
2. Explain the various forms of precipitation.
3. Without the atmosphere there cannot be climatology. Discuss this assertion.
4. What do you understand by climatic elements? Explain the factors affecting the distribution of temperature and precipitation.
5. What is precipitation and in what form does it exist?
6. Explain the various forms of precipitation.

7.0 REFERENCES/FURTHER READING

Areola, O. *et al* (1992). *Certificate Physical and Human Geography for Senior Secondary Schools*. Ibadan: University Press Plc.

Ojo, O. (1977). *The Climates of West Africa*. Ibadan: Heinemann Educational Books.

Ojo, O. *et al* (2001). *Fundamentals of Physical and Dynamic Climatology*. Sedec Publishers.

UNIT 4 DYNAMICS OF EARTH'S ATMOSPHERE

CONTENTS

- 1.0 Introduction
- 2.0 Objectives
- 3.0 Main Content
 - 3.1 Atmospheric Circulations
 - 3.1.1 Factors of Generation Circulation of the Atmosphere
 - 3.2 Atmospheric Circulation Systems
 - 3.2.1 The General Circulation of the Atmosphere
 - 3.2.2 Other Circulation
- 4.0 Conclusion
- 5.0 Summary
- 6.0 Tutor-Marked Assignment
- 7.0 References/Further Readings

1.0 INTRODUCTION

As earlier mentioned there are variations in the net radiation over the earth's surface and between the surface of the earth and the atmosphere. This situation is responsible for the dynamism experienced in the atmosphere. All atmospheric circulations or motions are caused by energy inequalities which produce temperature and pressure variations. This unit examines atmospheric circulations and some of the factors affecting them.

2.0 OBJECTIVES

At the end of this unit, you should be able to:

- explain some of the factors of atmospheric circulation
- describe the atmospheric motions at the various scales that is primary, secondary and tertiary scales.

3.0 MAIN CONTENT

3.1 Atmospheric Circulations

3.1.1 Factors of the General Circulation of the Atmosphere

The factors which influence the general circulation of the atmosphere include radiation balance, pressure gradient force, rotation of the earth etc.

Radiation Balance

Radiation balance is the difference between absorbed solar radiation and effective outgoing radiation. It adds up to zero for the earth's atmospheric system over a period of a year. This prevents the earth from getting warmer or cooler. Over shorter periods or small areas, on the other hand, this equilibrium does not occur. There is an excess of radiation balance in the low latitudes and marked deficits in the high latitudes. These results in a pole ward temperatures gradient both at the surface and in the atmosphere. The tropics are thus belts serving as a heat source, while the poles serve as heat sinks. If there were no circulation to transport the excess from equatorial regions to the poles, the tropics would be getting hotter and the high latitude getting colder. With the general circulation however, heat is transferred from the heat source to the heat sinks, so maintaining the average temperatures of the world. The leveling up of temperature is done mostly through the transfer of sensible heat and by the transportation of water vapour and its latent heat from the zones where evaporation is predominant to zones where precipitation is predominant and between the oceans, which provide 90 per cent of atmospheric water vapour and the continents.

Pressure Gradient

The atmosphere exerts pressure because air has weight or mass. The mass of a column of air over a given point determines the atmospheric pressure at the point. At sea level the average pressure is 1013 mb.

Horizontal pressure differences result primarily from temperature differences which produce air movements or winds. Thus, the underlying factors of most pressure differences at the bottom of the atmosphere are the same causes of horizontal distribution of temperature; latitude and land-water relationships being the most important. There are thus differences in the distribution of pressure due to thermal causes, and winds generally move from the areas with cold heavy air to areas with the lighter warm air. In addition there are also mechanical causes. The differences in the distribution of pressure between two adjacent areas in turn sets the air in motion and causes winds to blow from areas of high to areas of low pressure. The difference in relation to the slope of the two adjacent areas is called pressure gradient. A pressure gradient is thus the immediate cause of all air movement, the direction of air flow being from high pressure to low pressure, and the velocity of the air flow being directly related to the pressure gradient, that is the rate of change of pressure with distance. The pressure gradient is steep when the rate of change is great, and the steeper the gradient, the more rapid will be the flow of the air.

Rotation of the Earth

The rotation of the earth prevents direct meridional circulation that would result from the imbalance of net radiation of the world. Coriolis force is the term given to the force resulting from the rotation of the earth. As mentioned earlier, the effect of the force is at maximum at the poles while at the equator the effect becomes zero. The deflective force causes the winds to be deflected to the right in a northern hemisphere and to the left in the southern hemisphere.

Friction

The frictional force affects both wind speed and wind direction. The movement of air is retarded by friction between the moving air and the surface of the earth. The frictional effect of the earth's surface varies with height. It is of importance only below the frictional layer 1500 to 1000 metres although it tends to be deeper over rough terrain or under unstable conditions

There is also internal friction within the air itself, although this is very small and varies with height. Because the force acts in the opposite direction to the wind direction, the flow of surface air is not essentially parallel to the isobars as is the air in the free atmosphere which increases with the frictional force.

3.2 Atmospheric Circulation Systems.

Let us now examine the categories of the atmospheric circulations systems.

3.2.1 The General Circulation of the Atmosphere

The underlying cause of the general circulation is the unequal distribution of net radiation. These inequalities exist between the atmosphere and earth's surface on one hand and between the tropics and extra tropical areas on the other. To balance these inequalities, the atmosphere transfers warm air pole-wards and cool air equator wards.

If we assume a homogenous non-rotating earth the global wind systems would look much simpler than they are shown in Figure 3. However, with a homogenous rotating earth, the winds will be subject to both the pressure gradient and coriolis forces. Winds moving from areas of high pressure to those of low pressure are deflected as explained in unit 3, to the right of their path in the northern hemisphere and to the left of their path in the southern hemisphere. For a heterogeneous rotating earth, the pressure distribution patterns are more cellular than zonal owing to the

differential heating of land and water surface. The global wind systems will then be as shown in Figure 3. If we impose the varied topography of the earth's surface on this, the pattern of wind system will be more complex than that shown in Figure 3.

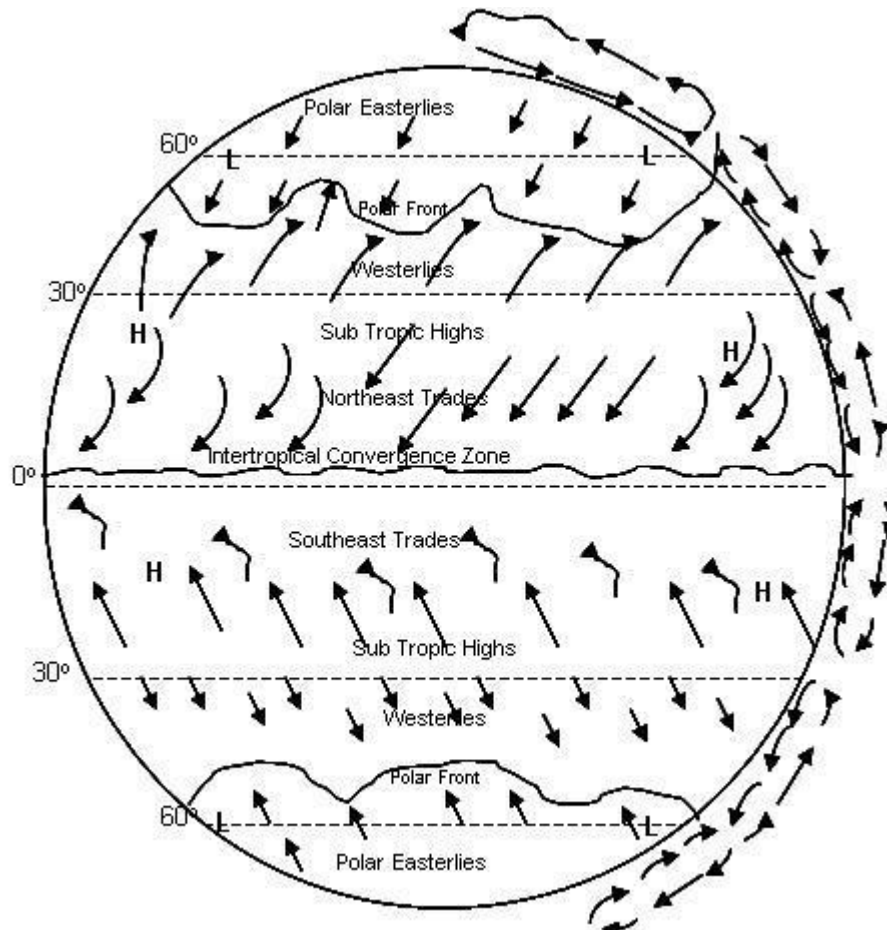

Fig 3: Global wind system

Relief can influence the wind systems in various ways. First they can pose a barrier to air flow; secondly, they can have a channeling effect on air flow. Relief also reduces wind speed at low levels through frictional drag on air flow.

The global pattern of general circulations is thus influenced by a change in any of the factors discussed above. The global wind systems discussed above are for the surface level only. Other wind systems like the Rossby waves, easterly waves and jet streams are also encountered at the middle and upper levels of the atmosphere.

3.2.2 Other Circulations

The day-to-day weather activities over a given area are determined more by secondary and tertiary circulation systems which are embedded in the

general circulation of the atmosphere. These include the monsoon, cyclones, anticyclones, land and sea breeze.

The Monsoon

The seasonal variation in the temperature between the land and sea result in the seasonal wind systems called monsoons. During summer, the continental land masses become warmer than the surrounding water surfaces, resulting in temperature induced low pressure centre over the land surface. The wind therefore blows from the sea to the land, bringing abundant moisture. (Fig. 3). During the winter however, the continental land masses are much colder than the seas. This consequently causes a shallow high pressure cell over land with a lower pressure over the adjacent water surface which leads to the development of a land to sea pressure gradient and wind. (Fig. 3). The cold dry air from the land is poor in moisture content and brings no precipitation.

Monsoons are best developed in eastern and southern Asia, because of the size of the continent which intensifies the continental effect on weather. In areas such as West Africa and North America, the systems are not as well developed.

Land and Sea Breezes

These occur as a result of diurnal variation in the heating of land and water and they may be called daily monsoons. They differ from the large seasonal monsoons because they result from lesser changes in pressure. During the day, the air moves from the sea to the much heated land while at night, a reversed condition occurs, the wind blows from the much cooled land to the sea (Ayoade 2002).

4.0 CONCLUSION

The atmosphere is far from being stable at any time. It is highly dynamic and this is attributable to the variation in the amount of solar radiation received over the earth's surface. Between the earth's surface and the atmosphere the global atmospheric circulation system has the regional and local circulation embedded in it and it is these lower level circulation systems that are responsible for the day to day weather activities over any given area.

5.0 SUMMARY

In this unit we have learnt that:

1. Radiation balance, pressure gradient force, rotation of the earth and frictional force are some of the factors of the general circulation of the atmosphere.
2. General circulation of the atmosphere is caused by unequal distribution of net radiation.
3. The atmosphere transfers heat from the equator pole wards and cold from the poles towards the equator.
4. There are other wind systems in the middle and upper atmosphere i.e. Rossby wave, easterly waves and jet stream.
5. The day-to-day weather is determined by secondary and tertiary circulation systems like the monsoons, cyclones anticyclones, land and sea breezes among others.

6.0 TUTOR-MARKED ASSIGNMENT

Discuss the propelling forces responsible for the pattern of atmospheric circulation. Succinctly enumerate the various systems of atmospheric motion.

7.0 REFERENCES/FURTHER READING

- Ayoade, J. O. (1983). *Introduction to Climatology for the Tropics*. ChiChester: John Wiley and Sons.
- Nieuwolt, S. (1977). *Tropical Climatology: An Introduction to the Climates of the Low Latitudes*. ChiChester: John Wiley and Sons.
- Ojo, O. (1977). *The Climates of West Africa*. Ibadan: Heinemann Educational Books.
- Ojo, O. *et al* (2001). *Fundamentals of Physical and Dynamic Climatology*. Lagos: SEDEC Publishers.
- Strahler, A.N. and Strahler, A.H (1973). *Environmental Geosciences: Interaction between Natural Systems and Man*. John Wileys and Sons.

UNIT5 RADIATION AND HEATING OF THE ATMOSPHERIC SYSTEM

CONTENTS

- 1.0 Introduction
- 2.0 Objectives
- 3.0 Main Content
 - 3.1 Radiation and Heating of the Atmospheric System
 - 3.1.1 The Sun
 - 3.1.2 Disposition of Solar Radiation in the Earth's Atmospheric System
 - 3.1.3 Terrestrial and Atmospheric Radiation
 - 3.1.4 Radiation Balance
- 4.0 Conclusion
- 5.0 Summary
- 6.0 Tutor-Marked Assignment
- 7.0 References/Further Readings

1.0 INTRODUCTION

Solar energy represents almost all the energy available to the earth (99.97%). As earlier mentioned, it is an important source of energy for life on the surface of the earth. It is the great engine which drives the earth's atmosphere and oceanic circulations. It generates weather and makes the earth a loveable place for plants and animals. Processes such as photosynthesis, on which man's existence partly depends are almost impossible without radiation

2.0 OBJECTIVES

At the end of this unit, you should be able to:

- describe the sun
- state how solar energy is transmitted to the earth
- state how the earth is heated
- state how the atmosphere is heated.

3.0 MAIN CONTENT

3.1 Radiation and Heating of the Atmospheric System

3.1.1 The Sun

The sun, which is a star of about medium mass, has a surface temperature of about 6000^oK. It emits a form of energy known as electromagnetic radiation. This energy travels about 150 million kilometers to reach the earth's surface and takes about 9 ½ minutes to complete the journey.

The totality of wavelength is known as solar spectrum. The solar spectrum consists of both short and long wave radiation. A wavelength may be defined as the distance from crest to crest of succeeding waves. The conventional unit used in the measurement of wavelength is the micron (1 micron = 0.000km or 10⁻⁴). The symbol used is μ . Another unit used which is smaller than the micron is angstrom =10⁸ cm. The total bulk of all solar radiation occurs in the narrow range of wavelength from 0.30 μ to 0.74 μ , usually referred to as short wave radiation. Short wave radiation is visible as light to human eye. The colours of visible radiation are violet, indigo, blue, green, yellow, orange and red.

The solar spectrum consists of:

1. X-rays, gamma rays, alpha rays and ultraviolet rays consisting about 9% of the total energy.
2. Visible light rays (0.4-0.74 μ) carrying 41%
3. Invisible infrared (heat) rays (0.7-3000 μ) consisting 50%.

The term short wave radiation is applied to the visible and ultraviolet portion of the spectrum (wavelengths less than 0.7 μ) as distinct from the infrared or long wave portion (longer than 0.7 μ). Radiation is energy in transit. When it comes in contact with an object or substance it may be transmitted, reflected or absorbed in proportions which depend on the nature of the medium and wavelength of the radiation. It is the amount of the radiation absorbed by a medium that is effective in heating it.

3.1.2 Disposition of Solar Radiation in the Earth's Atmospheric System

The solar radiation intercepted by the earth is either absorbed or returned back to space by scattering or reflection. Mathematically the disposition of solar radiation is expressed by

$$Q_s = Cr + Ar + Ca + Aa + (Q + q)(1 - \sigma) + (Q + q)\sigma$$

From the expression, the solar radiation incident on top of the atmosphere can be scattered and reflected back to space by cloud (Cr), cloud cover blocks the penetration of insolation. About 25% of incoming solar radiation is reflected back to space by clouds. Solar radiation can also be scattered or reflected by air molecules, dust particles and water vapour (Ar). Dust particles, air molecules and water vapour in the atmosphere are capable of scattering a lot of solar radiation. The scattering is either upward towards the space or downwards toward the earth's surface. About 6% of the insolation reaching the top of the atmosphere is scattered downward and reaches the surface as diffuse radiation. Radiation is also reflected by the earth's surface $(CQ + q)\sigma$, where Q and q are direct solar beam and diffuse solar radiation respectively and σ is the surface albedo.

On the other hand, solar radiation can be absorbed by cloud (Ca). Clouds act as temporary thermal reservoirs for they absorb a part of the energy they intercept. Solar radiation is also absorbed by air molecules, dust and water vapour (Aa). About 18% of the insolation is absorbed directly by ozone and water vapour. Ozone absorbs it mainly in the ultraviolet region consisting Hartley band (0.20-0.33 μ). Water vapour absorbs in the near infrared band centering at 0.93, 1.13, 1.42 and 1.47 μ . Water vapour is a selective absorber of radiation. Carbon dioxide absorbs radiation with wavelengths greater than 4 μ . The earth's surface represented by $(CQ + q)(1 - \sigma)$, also absorbs solar radiation. Land and water have different thermal properties and react differently to insolation. Land heats up rapidly and loses heat rapidly while water heats up slowly and releases heat slowly.

3.1.3 Terrestrial and Atmospheric Radiation

The surface of the earth when heated, becomes a source of long wave radiation. Because the surface temperature of the earth is 285^oK most of the radiation is emitted in infrared spectral range from 4 μ to 100 μ with a peak near 10 μ .

Like the earth, the atmosphere absorbs and emits radiant energy. Although the atmosphere is nearly transparent to short wave radiation, it easily absorbs terrestrial radiation. The principal absorbers being water vapour (5.3-7.7 μ and beyond 20 μ), Ozone absorbs (9.4-9.8 μ), carbon dioxide (16.9 μ) (13.1 -and clouds absorb radiation at all wavelengths. While the atmosphere absorbs only 24% of incoming solar radiation (short wave), 91% of infrared terrestrial radiation is absorbed.

The atmosphere in turn re-radiates the absorbed terrestrial radiation partly to space and partly back to the earth's surface. This is known as counter-radiation and is represented symbolically by the following

$$I = I_a + I_s \dots\dots\dots (i)$$

$$I_{\downarrow} = I_{\downarrow} + I_{\uparrow a(s)} \dots\dots\dots(ii)$$

From these two equations the effective outgoing radiation can be specified

$$I_{\uparrow} = I_{\downarrow} - I_{\downarrow} \dots\dots\dots (iii)$$

I_{\uparrow} is the effective outgoing radiation

3.1.4 Radiation Balance

Radiation balance or net radiation is the difference between the absorbed solar radiation by a surface and the effective outgoing radiation from the surface.

On the average, the earth's surface absorbs about 124 kilolangleys of solar radiation each year and in turn effectively radiates 52 kilolangleys yr⁻¹.

1. The Planetary Radiation Balance

Solar energy incident on outer edge of atmosphere	263
Reflected by clouds	63
Reflected by molecules, dust, water vapour	<u>15</u>
Total reflected by the atmosphere	78
Reflected from the earth's surface	<u>16</u>
Total reflected by surface and atmosphere	94
Absorbed by clouds	7
Absorbed by molecules, dust and water vapour	38
Total absorbed by the atmosphere	45
Absorbed at the earth's surface	<u>124</u>
Total absorbed by earth and atmosphere	169
2.	
Infrared radiation emitted by the earth's surface	258
Loss of space	<u>20</u>
Absorbed by the atmosphere (a)	238
Infrared radiation emitted by the atmosphere	355
Lost to space	<u>149</u>
Absorbed by the earth's surface as counter-radiation	206
Effective outgoing radiation from the earth's surface	52
Effective outgoing radiation from the atmosphere	<u>117</u>
Effective outgoing radiation from the earth and atmosphere	169

Modified from Sellers (1965)

This leaves the earth's surface with a balance of 72 kilolangleys yr⁻¹ usually designated by R_n and known as radiation balance. It is symbolically given as:

$$R_n = (Q+q) (1-\sigma) - I$$

Where (Q+q) (1- σ) is the absorbed solar radiation, Q and q are direct and diffuse solar radiation respectively, σ is the albedo and I is the effective outgoing radiation.

Similarly, radiation balance of the atmosphere (R_g) is defined. The atmosphere absorbs 45 kilolangleys of solar energy per year and radiates 117 kilolangleys yr⁻¹. Thus the atmosphere loses as much radiation in a year as the earth's surface gains. The balance of the whole system, surface (R_n) and the atmosphere (R_g) is therefore zero.

Although the global radiation balance is zero averaged over the year, it will not generally equal zero either seasonally or annually in any given latitude.

4.0 CONCLUSION

Solar radiation is very important to human existence on the earth's surface as it touches all spheres of man's life, particularly agricultural activities.

5.0 SUMMARY

1. The sun emits a form of energy known as electromagnetic radiation
2. The totality of wavelength is known as solar spectrum which consists of short and long-wave
3. The incoming solar radiation is scattered, reflected or absorbed by cloud, air molecules, dust particles, water vapour and the earth's surface.
4. The atmosphere is significantly heated by terrestrial radiation.

6.0 TUTOR-MARKED ASSIGNMENT

1. What is the importance of solar radiation to man?
2. Account for the disposition of solar radiation in the earth's atmospheric system.
3. Explain the radiation balance of the earth's atmospheric system.

7.0 REFERENCES/FURTHER READING

- Ayoade, J. O. (1983). *Introduction to Climatology for the Tropics*. ChiChester: John Wiley and Sons..
- Nieuwolts,S.(1977).*Tropical Climatology: An Introduction to the Climates of the Low Latitudes*. ChiChester: John Wiley and Sons.
- Ojo, O. (1977). *The Climates of West Africa*. Ibadan: Heinemann Educational Books.
- Ojo, O. *et al* (2001).*Fundamentals of Physical and Dynamic Climatology*. Lagos: SEDEC Publishers.
- Strahler, A.N. and Strahler, A.H (1973). *Environmental Geosciences: Interaction between Natural Systems and Man*. John Wileys and Sons.

MODULE 2

Unit 1	Atmospheric Moisture
Unit 2	The Dynamics of Pressure and Wind Systems
Unit 3	The Condensation and Precipitation Process
Unit 4	Seasonal Variations in Radiation, Daylight and Temperature
Unit 5	Seasonal Variations in Evaporation and Rainfall

UNIT 1 ATMOSPHERIC MOISTURE

CONTENTS

1.0	Introduction
2.0	Objectives
3.0	Main Content
3.1	Atmospheric Moisture
3.1.1	Evaporation and Evapotranspiration
3.2	Humidity
3.2.1	Distribution of Humidity
4.0	Conclusion
5.0	Summary
6.0	Tutor-Marked Assignment
7.0	References/Further Readings

1.0 INTRODUCTION

Water can exist in solid, liquid or gaseous states. It is a highly important element for all living things and the environment. Water in its gaseous state or “water vapour” forms the bulk of what we refer to as atmospheric moisture. Water vapour is of great significance in deciding weather and climate and so climatologists and meteorologists are interested in its amount and distribution over time and space. This unit examines the nature, amount and distribution of atmospheric moisture.

2.0 OBJECTIVES

At the end of this unit, you should be able to:

- understand the term atmospheric moisture
- define humidity and the various indices of humidity
- explain the distribution of humidity.

3.0 MAIN CONTENT

3.1 Atmospheric Moisture

3.1.1 Evaporation and Evapotranspiration

Atmospheric water vapour is derived from evaporation and transpiration. Evaporation is the process by which moisture in its liquid or solid form is converted into gaseous form –water vapour. Transpiration on the other hand refers to the loss of water from plants to the atmosphere. Evapotranspiration differs from evaporation because it describes water losses from surfaces where transpiration is a major contributor. Essentially, it combines evaporation and transpiration.

Availability of moisture at evaporating surface and the ability of the atmosphere to vaporise the water, remove and transport the vapour upward are fundamental factors that determine the rate of evaporation and evapotranspiration over any given area. Evaporation and evapotranspiration will occur at the maximum level if moisture is always available at the evaporating surface. This has given rise to the concept of potential evapotranspiration. However, moisture is not always available at the evaporating surface, and evaporation and evapotranspiration have often occurred below maximum level. This has also given rise to the concept of actual evapotranspiration.

Many factors including solar radiation, temperature, wind speed and humidity also determine evaporation and evapotranspiration. Energy is needed to vaporise water and in the absence of radiation data, energy is indicated by air temperature. Wind speed removes the moistened air lying over the evaporating surface and replaces it with dry air to maintain the evaporation process. The humidity of air determines the capacity of the air to hold moisture. It also affects the evaporation rate. The lower the humidity, the greater the capacity of air to hold moisture while the higher the humidity the lower the capacity of air to hold water.

Condensation and precipitation which have been explained in an earlier unit help to remove water vapour from the atmosphere. The most conspicuous aspects of the weather (e.g. rain, snow, hail, fog etc) result from the presence of water in the atmosphere.

3.2 Humidity

Humidity is a measure of the amount of water in the atmosphere. It does not cover the other forms of moisture in the atmosphere, i.e. liquid form (water droplets) and solid form (ice). Because of its origin (earth's surface) atmospheric water vapour is concentrated in the lower layers of

the atmosphere. In fact, about half of the total water vapour in the atmosphere is found below 2000 metres. The amount of moisture in the atmosphere decreases steadily with increase in height. Water vapour is virtually absent after the tropopause.

There are different ways of measuring the moisture content of the atmosphere. The indices of humidity usually applied include the following:

Absolute humidity: It is expressed in grains per cubic metres of air. It is the total mass of water in a given volume of air.

Specific humidity: This is the mass of water vapour per kilogram of air including its moisture.

Mass mixing ratio or humidity mixing ratio: It is the mass of water vapour per kilogram of dry air.

Relative humidity: It is the ratio of the actual moisture content of a sample of air to that which the same volume of air can hold at the same temperature and pressure when saturated. It is usually expressed in percentage.

Dew-point temperature: This is the temperature at which saturation will occur if the air is cooled at constant pressure without addition or removal of vapour.

Vapour pressure is the pressure exerted by the vapour content of the atmosphere in millibars.

The relative humidity is the most popularly used index for measuring air humidity. It is easily measured and indicates the degree of saturation of the air. However, it is highly influenced by the air temperature. A change in air temperature can change the value of relative humidity even though the moisture content remains constant. For instance, the relative humidity of the air varies inversely with temperature, being lower in the early afternoon and higher at night. It is important to note that relative humidity does not tell us about the quantity of moisture in the air but tells us how close to saturation the air is.

Unless they have been obtained at about the same hour of the day when air temperatures are not too different, relative humidity for different stations cannot be compared since the values are dependent on air temperature. For the purpose of comparison other indicators of atmospheric moisture such as the vapour pressure or the absolute

humidity should be used. Unlike relative humidity these measures are not unduly influenced by air temperatures.

3.2.1 Distribution of Humidity

Water vapour as earlier mentioned is the most important air component that has influence on weather and climate. It is highly inconstant varying from nearly zero up to a maximum of about 3% in the middle latitude, and 4% in the humid tropics. This variability in both place and time is of outstanding importance for the following reasons.

Water vapour is the source of all forms of condensation and precipitation.

Water vapour is a principal absorber of solar and infrared radiation. It therefore has an important influence on temperature. Because of its latent heat, the amount of vertical distribution of water vapour in the atmosphere indirectly affects the buoyancy of air and hence its tendency to ascend. This in turn is closely related to the formation of clouds and precipitation.

The latent heat of water vapour is an important energy source for atmospheric circulations. Humidity is an important factor of evaporation, a process that is important for animal and plant life.

Generally, relative humidity is greater over the ocean than over the continental areas. This reflects the high rate of evaporation due to the fact that the supply of water is unlimited at the ocean surface while over many land areas; water is an important limiting factor of evaporation because it is scarce. Also relative humidity is high throughout in very humid climates and low in arid and semi-arid climates. In seasonally humid areas, relative humidity is higher during the rainy season than during the dry season

The vapour pressure distributions have similar characteristics with relative humidity over the oceans and the very humid areas of the work; for instance, vapour pressures are almost at saturation level. In the arid and semi -arid areas, vapour pressures are low, causing the saturation deficit of evaporability of air to be high.

When vapour is continuously added to the atmosphere and the limit is reached, the air is said to be saturated. The resulting vapour pressure of the upper limit of water holding capacity is termed saturation vapour pressure. The saturation vapour pressure increases with higher temperatures and reaches a maximum at 1013 mb at which point the

introduction of more water vapour into the air results in condensation of an equivalent amount of water vapour.

The saturation point can be reached at a particular temperature without the moisture content changing. The critical temperature at which the saturation vapour pressure is reached is known as the dew point temperature, which may be defined as the temperature at which the quantity of water vapour in the air represents the maximum holding capacity of the air at that temperature. This critical temperature may be attained by increasing the water vapour content of the air at a particular temperature, or decreasing the air temperature and consequently, reducing the relative moisture content of the air at a constant temperature. Once the dew point is reached, any further cooling beyond it will result in condensation either in the form of minute particles of water if temperature is above 0°C or ice if it is below 0°C . The dew point and relative humidity are closely related. At high relative humidity, the air is close to saturation and only slight cooling will be required to attain the dew point. On the other hand, when relative humidity is low, a large amount of cooling is required for the dew point to be attained.

4.0 CONCLUSION

Atmospheric moisture is made up of water vapour, water droplets and ice. They are derived from evaporation and removed by condensation and precipitation.

5.0 SUMMARY

In this unit we have learnt that:

1. Water vapour highly influences weather and climate
2. Atmospheric moisture is derived through evaporation from the water bodies on the earth's surface
3. Humidity is a measure of the amount of water vapour in the atmosphere.
4. The amount of water vapour decreases with height.
5. There are different indices for measuring humidity
6. Relative humidity is the most popularly used index for measuring air humidity.
7. Relative humidity is higher over the ocean than over the continent.

6.0 TUTOR-MARKED ASSIGNMENT

1. Explain the process of acquisition and removal of atmospheric moisture.
2.
 - a. What do you understand by relative humidity?
 - b. Explain the dew point temperature and how it is related to relative humidity.

7.0 REFERENCES/FURTHER READING

Ayoade, J.O. (2004). *Introduction to Climatology for the Tropics*. Ibadan: Spectrum Books Limited.

Ayoade, J.O. (2002). *Introduction to Agro Climatology*. Ibadan: Vintage Publishers.

Donald Ahrens, C. (1994). *Meteorology Today: An introduction to Weather, Climate and the Environment* (5th ed). U.S.A: West Publishing Company.

Ojo, O. *et al* (2001). *Fundamentals of Physical and Dynamic Climatology* SEDEC Publishers.

UNIT 2 THE DYNAMICS OF PRESSURE AND WIND SYSTEMS

CONTENTS

- 1.0 Introduction
- 2.0 Objectives
- 3.0 Main Content
 - 3.1 Pressure and Wind Systems
 - 3.1.1 Pressure Belts and Planetary Winds
- 4.0 Conclusion
- 5.0 Summary
- 6.0 Tutor-Marked Assignment
- 7.0 References/Further Readings

10 INTRODUCTION

The movement of air in the atmospheric system may be vertical or horizontal; in the latter case it is commonly known as wind. Winds result from differences in air pressure which in turn may be caused by differences in temperature and the force exerted by gravity, as pressure decreases rapidly with height. An increase in temperature causes air to heat, expand, become less dense and rise, creating an area of low pressure below. Conversely, a drop in temperature produces an area of high pressure. In this unit, we will be looking at the global distribution of pressure and directions of winds.

2.0 OBJECTIVES

At the end of this unit, you should be able to:

- explain the global distribution of pressure
- state the various planetary winds and explain their directions.

3.0 MAIN CONTENT

3.1 Pressure and Wind Systems

This refers to the circulation of air over the earth's surface as a result of differences in pressure. Along the equator and within 5 degrees north and south, is the Equatorial low pressure belt, where the midday sun is never far from vertical. It is a belt of intense overheating which causes the air to expand, become lighter and rise. It is a zone of wind convergence and often called the Doldrums.

At about 30° north and south occur the sub-tropical high pressure belts where the air is comparatively dry and the winds are calm and light. It is a region of descending air currents or wind divergence and anticyclones. It is frequently called the horse latitude. Around the latitudes 60° north and south are the two temperate low pressure belts which are also zones of convergence with cyclonic activity. The sub-polar low pressure areas are best developed over the oceans, where temperature variations between the summer and winter are negligible.

At the north and south polar 90° north and south where temperatures are permanently low, are the polar high pressure belts. Unlike the water masses of the high latitude in the southern hemisphere, high pressures of corresponding latitude in the northern hemisphere are a little complicated by the presence of land mass. Some pressure differences between the summer and winter can be expected.

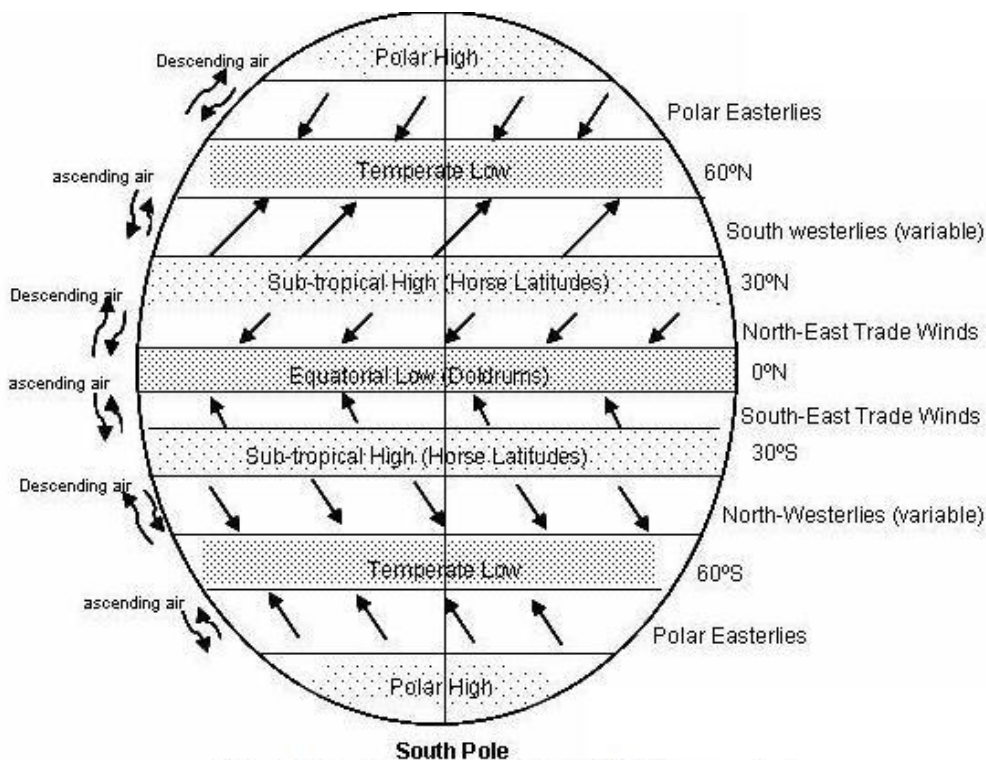

Fig. 4: World pressure belts and planetary winds

3.1.1 Pressure Belts and Planetary Winds

From the global permanent pressure belts, winds tend to blow from the high pressure belts to low pressure belts as planetary winds. Figure 4 above shows the actual arrangement of the global pressure and wind belts. However, it is important to note that there are seasonal variations in both pressure and winds.

The winds blowing out from the sub-tropical high pressure belt in the northern hemisphere towards the equatorial low are called north trade winds and those in the southern hemisphere are called south east winds. Winds are always named after the direction they come from. The trade winds are the most regular of all the planetary winds. They blow with great force and in a constant direction. They have great capacity for holding moisture because they blow from the cooler sub-tropical latitudes to the winter tropics.

Winds blow from the sub-tropical high pressure belts towards the temperate low pressure belts as the variable westerlies. Under the effect of the coriolis force, they become the south-westerlies in the southern hemisphere. They are more variable in the northern hemisphere, but they play an important role in carrying warm equatorial waters and winds to the western coasts of the temperate lands. They bring much precipitation to the western coasts of continents. The weather is damp and cloudy and the seas are stormy and violent.

Finally, the polar easterlies blow out from the polar high pressure belts towards the temperate low pressure belts. They are extremely cold winds as they come from the tundra and ice- cap regions. They are more regular in the south than in the north.

4.0 CONCLUSION

There are areas of permanently high and low pressure on the globe. Winds originating from these pressure belts also have their direction influenced by coriolis force.

5.0 SUMMARY

In this unit we have learnt that:

1. Wind is the horizontal movement of air
2. Wind results from differences in air pressure
3. There are various areas of permanently high and permanently low pressure on the globe
4. Winds are named after the directions they come from
5. Winds are deflected from their original direction by coriolis force.

6.0 TUTOR-MARKED ASSIGNMENT

1. Explain the distribution of pressure and wind on a global scale.
2. With the aid of a diagram, explain the distribution of world pressure and wind systems

7.0 REFERENCES/FURTHER READING

- Areola, O. *et al* (1992). *Certificate Physical and Human Geography for Senior Secondary Schools*. Ibadan: University Press Plc.
- Ojo, O. (1977). *The Climates of West Africa*. Ibadan: Heinemann Educational Books
- Ojo, O. *et al* (2001). *Fundamentals of Physical and Dynamic Climatology*. SEDEC Publishers.
- Strahler, A.N. and Strahler, A.H (1973). *Environmental Geosciences: Interaction between Natural Systems and Man*. John Wileys and Sons.

UNIT 3 THE CONDENSATION AND PRECIPITATION PROCESS

CONTENTS

- 1.0 Introduction
- 2.0 Objectives
- 3.0 Main Content
 - 3.1 Condensation
 - 3.2 Precipitation
 - 3.2.1 Types of Precipitation
- 4.0 Conclusion
- 5.0 Summary
- 6.0 Tutor-Marked Assignment
- 7.0 References/Further Readings

1.0 INTRODUCTION

Atmospheric moisture exists in the form of water vapour or ice. The condensation and precipitation process essentially act to remove water from the atmosphere. This unit examines the processes that result in both condensation and eventually precipitation.

2.0 OBJECTIVES

At the end of this unit, you should be able to:

- explain how condensation takes place in the atmosphere
- explain the theories of rain drop formation
- explain the types of precipitation

3.0 MAIN CONTENT

3.1 Condensation

Condensation can be defined as the formation of water droplets when air has been cooled beyond its dew point. Air may be cooled by direct radiation from the surface of the earth during a clear night; the horizontal movement of warm air over a cold surface, the mixing along of the margins of two air currents of marked different temperatures; the movement of air from warmer to cooler latitudes, and by far the most important, by ascent. Each form of cooling may produce condensation of different degrees and with different results.

For condensation to take place, it is necessary for some kind of nuclei to be present on which the droplets can form. These nuclei include

particles of dust and smoke, salt from the ocean, pollen, and negative ions produced by the passage of radiation through the atmosphere.

The condensed droplets when formed are so minute that they float in the air as fog or clouds. Larger drops form on leaves and grass as dew, or hoar-frost if temperature is below freezing point. When droplets coalesce in the air to a certain critical size, they may fall to earth as one or other of the forms of precipitation earlier discussed. The formation of raindrops is highly complex and it is not actually clear how droplets coalesce, though certain theories propose electrical attraction, supercooling followed by freezing into ice particles, and turbulence causing coalescence by collision.

Drops may form and continue to exist in liquid form, even when the temperature is below freezing point, as long as air is undisturbed. This phenomenon is known as super cooling, and has a number of important meteorological effects. A good example is the accretion of ice on aircraft. If an aircraft passes into a cloud consisting of large drops of super cooled water, with the air temperature at or below freezing point, a considerable thickness of clear ice may form as each drop freezes on contact with the leading edges of the wings. Similarly, glazed frost forms when super cooled water freezes on branches, telephone wires and road surfaces. The main forms of condensation include dew, frost, fogs and clouds which have been discussed in Unit 3.

3.2 Precipitation

Various rain drop formation theories are said to have been put forward in the past and virtually all have been rejected for various reasons. According to Ayoade (2004), the two theories currently accepted are the Bergeron-Findeisen and Coalescence theories.

The Bergeron-Findeisen theory of rain drop formation submits that ice crystals within clouds tend to grow larger at the expense of the water droplets until they become too heavy to be supported within the cloud and consequently fall. These ice crystals will melt to form rain drops if they encounter warmer air as they descend. If not, they will fall as snow. When the temperature near the earth's surface is about freezing level, the ice crystals will partially melt and fall as sleet, a mixture of rain and snow. The ice crystals grow larger at the expense of the water droplets because the saturation vapour pressure over ice is less than over water. This means that vapour which is only saturated with respect to water is super saturated with respect to ice. Condensation therefore occurs on the ice crystals at the expense of the super cooled water droplets.

The Bergeron-Findeisen theory is supported by observation and laboratory experiments. For instance, in extra tropical areas it is generally observed that significant precipitation always comes from clouds whose tops extend beyond the freezing level in the atmosphere whereas lower clouds yield no more than mist or drizzle. Also, radar experiments have confirmed the existence of both water droplets and ice crystals in clouds extending beyond the freezing level and that such cloud give significant precipitation. Finally, in cloud seeding experiments clouds have been made to produce rain by seeding with fine dry ice (solid form of Co_2) or silver iodide which has crystal structure very similar to that of ice.

Rain drop formations in tropical clouds are usually warm because they do not extend into the freezing level in the atmosphere. These clouds are therefore made up solely of water droplets. And yet these clouds produce heavy rainfall. Within such clouds, raindrops grow by the coalescence process. The larger water droplets within clouds fall at a faster rate than the smaller ones, overtaking and absorbing the smaller droplets along their paths. The larger droplets also drag or sweep the smaller ones and absorb them (Fig. 5).

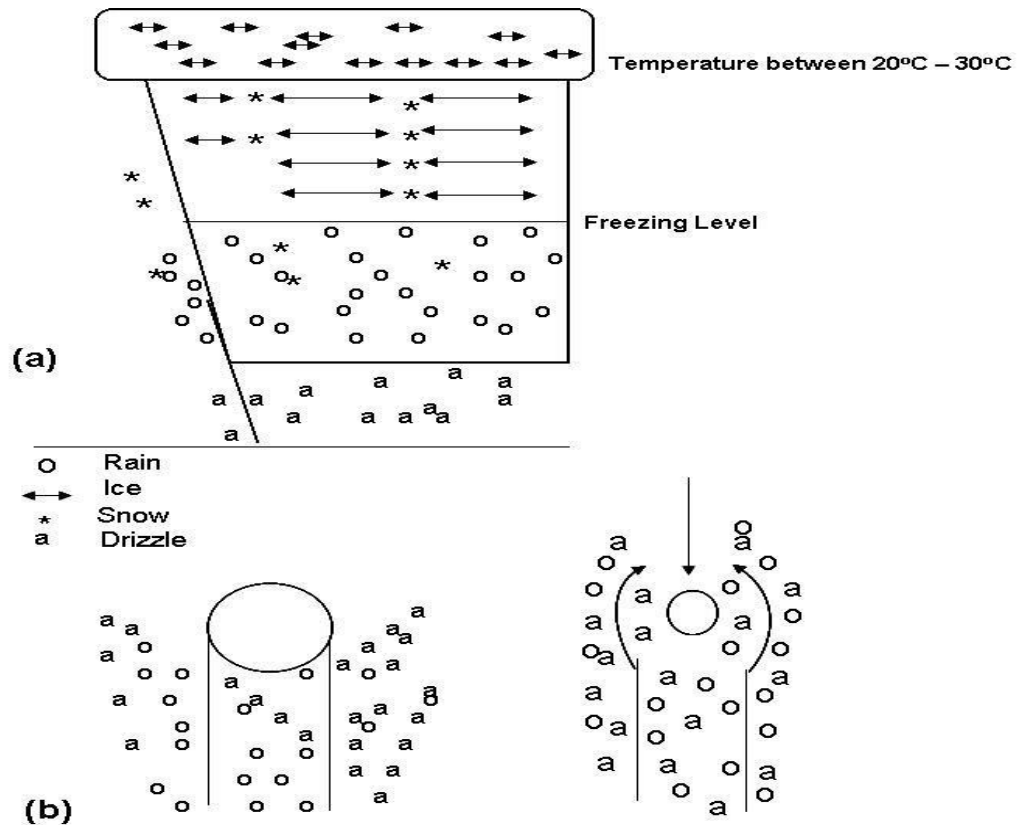

Fig. 5: Processes of raindrop formation according to (a) Bergeron-Feideisen theory and (b) coalescence theory (Source: Ayode, 2004)

Experimental results show that the coalescence process allows a more rapid growth of raindrops than simple condensation although it is initially rather slow.

For condensation and precipitation to occur naturally, the appreciable ascent of an air-mass is essential. This ascent is brought about in three main ways; hence there are three main types of precipitation:

1. Convective rainfall due to surface heating,
2. Orographic or relief rainfall due to ascent over land, particularly over a high range of hills and
3. Frontal or cyclonic rainfall, when either a mass of warm air over runs cold air or the latter undercuts the former.

3.2.1 Types of Precipitation

Precipitation types are classified on the basis of the processes which led to their formation. There are three types of precipitation.

1. Convective precipitation (Fig.6): This type of precipitation is common in the tropics. When the earth's surface is heated up, moisture laden vapour rises because heated air always expands and becomes lighter. Air rises in a convection current after prolonged heating. In ascending, water vapour condenses into cumulonimbus cloud which reaches its maximum in the afternoon. Hot, rising air has great capacity for holding moisture. As air rises it cools and when saturation point is reached torrential down pours occur, often accompanied by thunder and lightening. These downpours may not be useful for agriculture because they are so intense that they do not sink into the soil but drain off almost immediately. In fact they may cause serious erosion in forms of slope wash and gulying



Fig. 6: Convective rainfall

2. Relief or orographic precipitation (Fig. 7): The second cause of air rising is associated with land form barriers such as mountains, hills, and other highlands. This type is known as orographic precipitation. In this case, the barriers lie across the paths of moisture bearing winds. Examples in West Africa include precipitation caused by the rising air along the Futa Jallon Highlands, the Jos Plateau and the Cameroon Mountains (rainfall in Jos Plateau is higher than the average for its latitude). As the air is forced to rise by the highlands, the air cools at the adiabatic rate. If cooling is sufficient, rain may fall. As the air passes over the highest point of the highlands, it begins to descend on the leeward side. As it descends, it undergoes warming and becomes drier. This belt of relatively drier climatic conditions, is usually called the “rain shadow”, and is characteristic of the leeward sides of the highland areas.

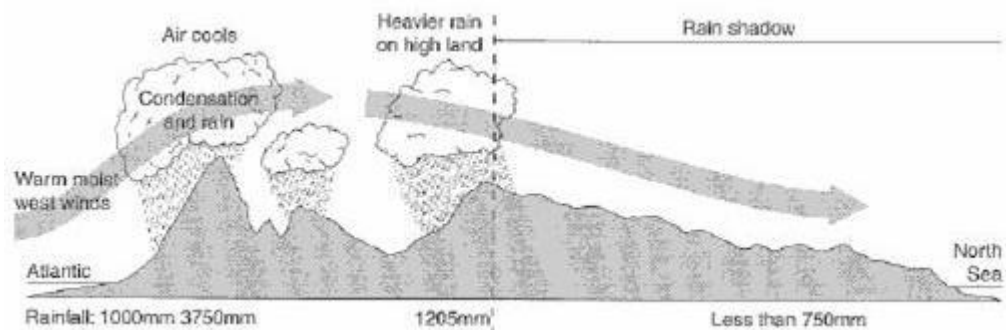

Fig. 7: Relief Rainfall

3. Frontal, convergence and disturbance precipitation (Fig. 8): This type of precipitation is caused through the convergence of air masses with contrasting characteristics. This type of precipitation is not common in West Africa and only occasionally occurs when influences of the mid latitude depressions extend as far south as they did for instance in 1960. The air ascending at the intertropical convergence zone (ITCZ) is dry and stable and consequently, not rain producing. On the other hand, true fronts may be formed in many convergent areas, such as the mid-latitudes where the air masses are of contrasting character in terms of temperature and humidity.

frontal rainfall

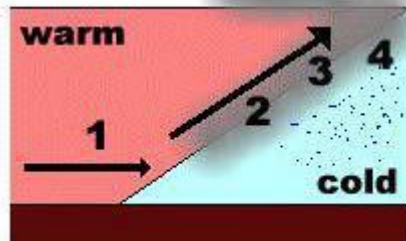

Fig. 8: Frontal rainfall

What are the various forms of precipitation you have learnt? Using relevant diagrams, enumerate the types of precipitation

4.0 CONCLUSION

Condensation is a necessary condition for precipitation to occur and precipitation can occur in different ways.

5.0 SUMMARY

In this unit we have learnt that:

1. Condensation occurs when air is cooled beyond dew point.
2. Air is cooled in different ways.
3. The presence of nuclei is important for condensation to occur.
4. There are two theories of raindrop formation, that is, Bergeron-Findeisen and coalescence theories.
5. The ascent of air is essential for condensation and precipitation to occur
6. There are three types of rainfall, that is, convective, orographic and frontal rainfall.

6.0 TUTOR-MARKED ASSIGNMENT

1. Describe the mode of origin and characteristics of (a) Convective (b) Orographic and (c) Frontal precipitation.
2. Explain the two theories of raindrop formation.
3. Discuss the propelling forces responsible for the pattern of atmospheric circulation.
4. What is the importance of solar radiation to man?
5. Account for the disposition of solar radiation in the earth's atmospheric system.
6. Explain the radiation balance of the earth's atmospheric system.

7. Explain the process of acquisition and removal of atmospheric moisture.
8.
 - a. What do you understand by relative humidity?
 - b. Explain the dew point temperature and how it is related to relative humidity.
9. Explain the distribution of pressure and wind on a global scale.
10. With the aid of a diagram, explain the distribution of world pressure and wind systems.
11. Describe the mode of origin and characteristics of
 - a. Convective precipitation
 - b. Orographic precipitation
 - c. Frontal precipitation
12. Explain the two theories of raindrop formation.

7.0 REFERENCES/FURTHER READING

- Ayoade, J.O. (2004). *Introduction to Climatology for the Tropics*. Ibadan: Spectrum Books Limited.
- Ojo, O. *et al* (2001). *Fundamentals of Physical and Dynamic Climatology*. Lagos: SEDEC Publishers.
- Monkhouse, F.J. (1979). *Principles of Physical Geography*. Britain: Hodder and Stoughton.

UNIT 4 SEASONAL VARIATIONS IN RADIATION, DAYLIGHT AND TEMPERATURE

CONTENTS

- 1.0 Introduction
- 2.0 Objectives
- 3.0 Main Content
 - 3.1 Seasonal Variations in Radiation
 - 3.2 Seasonal Variations in Daylight
 - 3.3 Seasonal Variations in Temperature
- 4.0 Conclusion
- 5.0 Summary
- 6.0 Tutor-Marked Assignment
- 7.0 References/Further Readings

1.0 INTRODUCTION

Agriculture is the mainstay of most countries in the tropics. Unfortunately agriculture is highly vulnerable to climate variations. To improve food production in tropical countries, it is essential to know the value of climatic elements and their daily, monthly, seasonal and intensities values.

2.0 OBJECTIVES

At the end of this unit, you should be able to:

- describe the seasonal variations in the amount of solar radiation, daylight and temperature
- identify the major causes of the seasonal variations.

3.0 MAIN CONTENT

3.1 Seasonal Variations in Radiation

The sun is the main source of energy for the earth. It emits radiant energy which is received by the earth as solar radiation or insolation.

The amount of insolation received at any place on earth depends mainly on the length of day and the angle of midday sun. Other factors include distance from the sun, atmospheric absorption, reflection and scattering, latitude, the nature of the surface, elevation and aspect.

At the time of summer solstice (June 21st), the noon rays of the sun are vertical on the tropic of cancer (23 1/2 °N) and the length of day increases from 66 1/2^o (Antarctic Circle) in the winter hemisphere to the pole in the summer hemisphere. The northern hemisphere experiences maximum solar radiation. The northern hemisphere actually receives two to three times the amount of solar radiation received by the winter hemisphere. Neglecting, for the moment the effects of the atmosphere, on June 21st, the zonal solar energy curve, beginning at zero at the Antarctic circle continues to rise steadily up to about latitude 40 °N in spite of the fact that the sun's rays are increasingly more oblique north of 23 1/2°N. North of this latitude, however there is a slight decline in solar radiation which continues to about latitude 62°N because the more oblique rays of the sun offset the increased length of day. But the solar energy curve again rises north of 62°N and reaches an absolute maximum at the North Pole. The conditions in the southern hemisphere on December 22nd is the exact reverse of what obtains in the northern hemisphere on June 21st (Fig 9) Fig 9.1 (Ayoade, 2002, pg 54, Fig 4a and b).

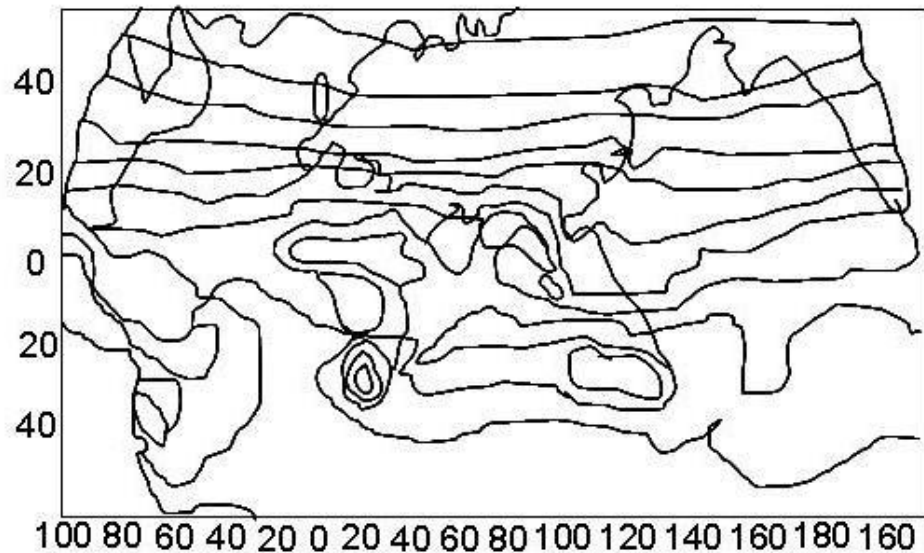

Fig. 9(a): Global distribution of insolation in December in kgcal/cm² per month, (Source: Ayoade, 2002)

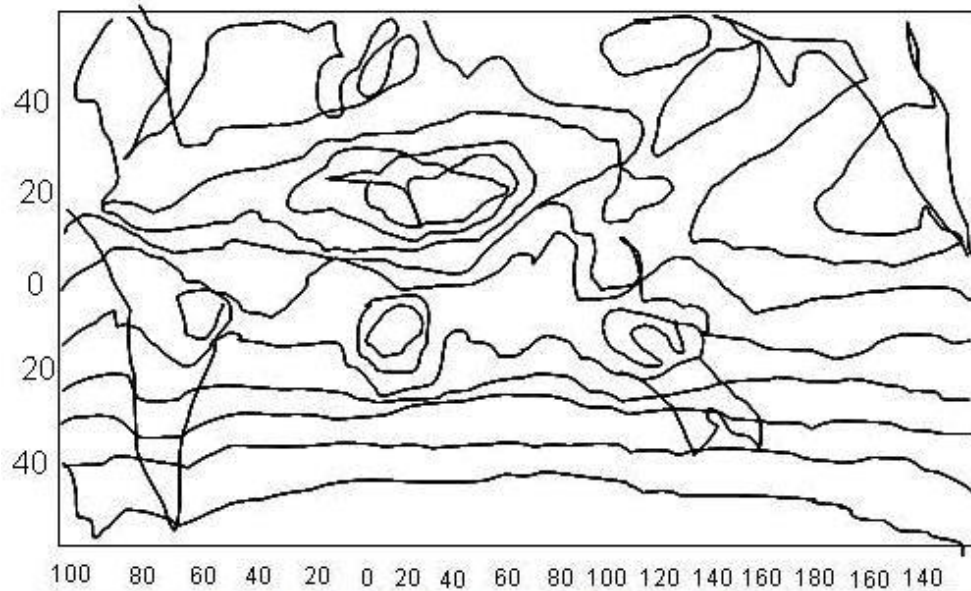

Fig. 9(b): Global distribution of insolation in June in kcal/cm² per month (Source: Ayoade, 2002)

At the time of the equinoxes (about March 21 and September 23) when the sun's noon rays are vertical at the equator and the tangent may reach the poles, latitudinal distribution of solar radiation resembles that for the year as a whole, since the maximum is at the equator with minima at the poles. During these times both the northern and southern hemispheres receive approximately equal amounts of the solar radiation.

For the year as a whole, solar radiation reaches a maximum at the equator and diminishes gradually and regularly toward minimum at either pole. At the poles the total amount of solar radiation received for the entire year is about 40% of that received at the equator.

In West Africa, solar radiation values are less along the coastal areas than inland of the region because of cloud cover. The values of radiation are also less during the rainy season than during the dry season because of the relatively heavy cloud cover.

3.2 Seasonal Variations in Day Light

The duration of insolation is indicated by length of day or day light and its variations depend largely on the earth's revolution.

On June 21st (summer solstice), the earth is so located in its orbit that the north polar end of its axis tilts at the full $23\frac{1}{2}^{\circ}$ towards the sun. At this position, the northern hemisphere is inclined towards the sun while the southern hemisphere tips away from the sun. On this day, the daylight increases from zero on $66\frac{1}{2}^{\circ}$ (Antarctic circle) of the winter hemisphere

towards the north pole until it is 24 hours north of the Arctic circle ($66\frac{1}{2}^{\circ}\text{N}$). On December 22nd (winter solstice), the earth is so positioned that the north polar axis again leans the full $23\frac{1}{2}^{\circ}$ directly away from the sun making the southern hemisphere to tip towards the sun and the northern hemisphere away. The conditions of daylight are exactly a reverse of that of June 21st. Daylight increases from zero on the (Arctic circle) in the winter hemisphere until it is 24 hours south of $66\frac{1}{2}^{\circ}\text{S}$ (Antarctic circle). During the equinoxes (March 21st and Sept. 23rd) the earth's axis makes a right angle with a line drawn to the sun, and neither the north nor South Pole is tipped towards the sun. On these days all places all over the world have equal day and equal night. In summary, places on the summer hemisphere enjoy longer days than those having winter but the total annual exposure to the sun is the same for all places on earth. The difference between summer and winter daylights increases from the equator reaching its extreme poles.

Throughout the year the length of day is equal at the equator twelve hours and seven minutes. According to Nieuwolt (1977), astronomically the duration would be twelve hours exactly but it takes $3\frac{1}{2}$ minutes for the upper half of the sun to disappear under the horizon at sunset and similarly, $3\frac{1}{2}$ minutes before the centre of the sun's disc is at the horizon while the upper half of it already provides insolation at sunrise.

The difference between the shortest and the longest day of the year grows with increasing latitude. In the low latitudes the increase is about 7 minutes per degree while in higher latitudes (between 50° and 60°); it amounts to about 28 minutes per degree of latitude. In conclusion, seasonal variations in daylight in the tropics are insignificant.

3.3 Seasonal Variations in Temperature

Temperatures are largely controlled by incoming and outgoing radiation. However, a number of other factors also influence surface temperatures and their distributions both over time and place. Surface air temperatures also show a variation with latitude.

There is a general increase in seasonal variation of air temperature with latitude. In the tropics, the absence of a cold season indicates that temperature variations between the seasons are generally small. In short the tropics can be said to have seasonal temperature uniformity. The main reason for this seasonal temperature uniformity is the small differences in the amount of net radiation received in the different seasons. The temperature uniformity is strongest around the equator and decreased pole wards with increasing latitude. Towards the outer limits of the tropics thermal differences with place increase rapidly especially over the continental areas (Fig 10).

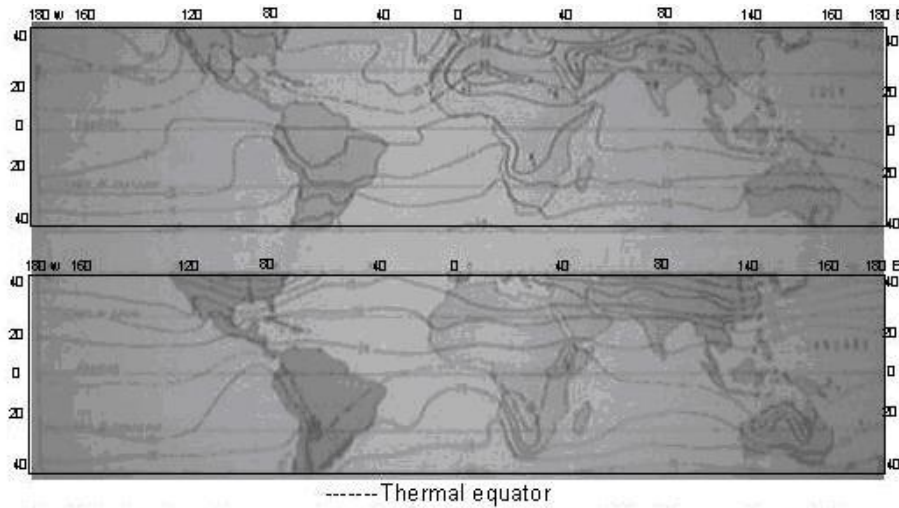

Fig. 10: Sea level temperatures in July and January ($^{\circ}\text{C}$). The position of the thermal equator (temperatures reduced to sea level)

The variations are found to be more marked over the land than over the ocean. This is because land surfaces are rapidly and intensely heated by solar radiation, whereas under equal radiant energy water surfaces are heated more slowly during the summer. On the other hand land surfaces cool more rapidly and reach much lower temperatures than the water surfaces during the winter.

Outside the tropics, temperatures vary widely between the seasons. Certain definite centres of high and low temperatures occur during the summer and winter respectively. These are found over land masses. In July, high temperature centres occur over Siberia (-46°C), northern most North America (-34°C) in January. A permanent centre of low temperature occurs in Greenland and Antarctica. These are two regions of massive ice sheets.

From about 6 degrees latitude, there is a temperature regime, in which the temperatures are higher in the spring (Feb, March, April) than in summer. This is as a result of cloudiness which characterises the rainy season (summer). The rainy season (summer) is characterised by heavy cloud overcast particularly in the day. This helps in reducing temperatures. This is not so in spring which is characterised by many days with a clear sky.

In Nigeria the highest air temperatures are normally in April in the northern parts and a little earlier in the south. Minimum temperatures in the north are usually recorded about December. In the south there is a little difference between the December temperatures and the relatively low temperatures of the rainy season, the lowest temperatures of the year may even be recorded during the rainy season.

4.0 CONCLUSION

Seasonal variations in solar radiation, daylight and temperature are mainly due to the revolution of the earth and more marked in the mid and high latitude.

5.0 SUMMARY

1. Globally, the summer hemisphere receives two to three times the amount of solar radiation received by the winter hemisphere. In most of the tropics, particularly West Africa radiation is lower during the rainy season than during the dry season because of the relatively heavy cloud cover.
2. Places on the summer hemisphere enjoy longer days than those on the winter hemisphere. Seasonal variations in daylight in the tropics are insignificant.
3. Generally seasonal variations of air temperature increase with latitude. In the tropics temperature variations between the seasons are quite small.

6.0 TUTOR-MARKED ASSIGNMENT

1. Discuss the effect of the revolution of the earth on the global distribution of solar radiation.
2. Explain the seasonal variations in daylight in the world.
3. Why is there no cold season in the tropics?

7.0 REFERENCES/FURTHER READING

- Ayoade, J.O. (1983). *Introduction to Climatology for the Tropics*. John ChiChester: Wiley and Sons.
- Nieuwolts, S. (1977). *Tropical Climatology: An Introduction to the Climates of the Low Latitudes*. ChiChester: John Wileys and Sons,
- Ojo, O. (1977). *The Climates of West Africa*. Ibadan: Heinemann Educational Books.
- Ojo, O. *et al* (2001)..*Fundamentals of Physical and Dynamic Climatology*. Lagos: SEDEC Publishers.
- Strahler, A.N. and Strahler, A.H (1973). *Environmental GeoScience: Interaction between Natural Systems and Man*. ChiChester: John Wileys and Sons.

UNIT 5 SEASONAL VARIATIONS IN EVAPORATION AND RAINFALL

CONTENTS

- 1.0 Introduction
- 2.0 Objectives
- 3.0 Main Content
 - 3.1 Seasonal Variations in Evaporation
 - 3.1.1 Seasonal Variations in Rainfall
- 4.0 Conclusion
- 5.0 Summary
- 6.0 Tutor-Marked Assignment
- 7.0 References/Further Readings

1.0 INTRODUCTION

Evaporation is the sources of all atmospheric moisture including rainfall. It is the reverse of precipitation in the hydrological cycle. Food production in the tropics depends largely on the characteristics, amount and duration of rainfall. Productivity can be improved by adjusting planting dates so that crops can take advantage of rainfall conditions.

2.0 OBJECTIVES

At the end of this unit, you should be able to:

- define evaporation and evapotranspiration
- state the differences between actual and potential evapotranspiration
- describe the seasonal variations in the amount of evaporation and rainfall.
- identify the major causes of the seasonal variations.

3.0 MAIN CONTENT

3.1 Seasonal Variations in Evaporation

Evaporation is the physical processes of molecular transfer involving a change of state of water from liquid or solid into gas. The process of evaporation requires energy to be expended in overcoming the intermolecular attractions of the water particles. This energy is largely provided by the removal of heat from the immediate surroundings causing apparent heat losses. Evaporation may occur either from free water surfaces such as rivers, ponds and lakes, from bare soil, or from

water which has been intercepted by plant leaves or stems. Evaporation also occurs through transpiration from plants. Water loss from transpiration in combination with evaporation is termed Evapotranspiration.

If moisture is not limiting at the evaporating surface, evaporation and evapotranspiration occur at the maximum rate possible for the environment. This has given rise to the concept of potential evapotranspiration. Moisture is however; hardly always available in sufficient quantities at the evaporating surface, so that evaporation and evapotranspiration often occur at rates below those that would take place assuming water was always available. This is known as actual evapotranspiration.

Because of the problems involved in the study of actual evapotranspiration more attention has been paid to the study of potential evapotranspiration particularly for agricultural purposes. Budyko (1956) concluded that evaporation from field crops is close to the potential rate when the soil moisture is greater than or equal to 70-80% of the value of field capacity. Thornthwaite and Mather (1955) said that evaporation and evapotranspiration would continue at the potential rate as long as the soil was at field capacity.

The conditions of evaporation in the dry season in West Africa show a general increase in land from the coast in a zonal pattern although some substantial distortions occur along the coast and in the interior between 11°N and 18°N. South of latitude 9°N there is a remarkable decrease in evaporation probably because of the rapid change in cloudiness between areas to the north and south of the latitude. The smallest values of evaporation are along the coast. The reason for this is that the air mass is still present in coastal areas and it is cloudier. This reduces the incoming radiation available for evaporation.

During the rainy season, the spread of cloud becomes more uniform and consequently there is a more regular distribution of evaporation, particularly over areas to the south of approximately latitude 15°N, where the values are less than 75 mm. The lowest values are along the coast. This again reflects the low value of net radiation available for evaporation because of higher cloud density and consequently a greater loss in incoming solar radiation. Evaporation is relatively low along the southern coastland and high near the desert. Values are generally higher in dry season than in rainy season particularly along the coast in the tropics. Generally, the evaporation rate is highest toward the end of the dry season, namely in March and April. The lowest values are recorded in the wet season namely July and August in Nigeria due to considerable

increases in cloud and highly reduced amounts of insolation (Oguntoyinbo, 1978).

3.1.1 Seasonal Variations in Rainfall

In general, high rainfall totals occur over the equatorial regions and the monsoon lands of south-east Asia, while the deserts receive the least amount of rainfall. With respect to seasonal variations in rainfall the pattern is generally zonal for both seasons, especially in the low latitudes. In the middle latitudes, on the other hand, the pattern is non zonal. The continents have more of their rainfall during summer than during the winter months.

In the tropics the seasonal variation is second in importance to the total amount of rainfall. It is the prime controlling factor of the farming calendar in most of the tropics – clearing, ploughing, ridging, planting, application of fertilizer, weeding and harvesting. In many parts of the tropics, the onset, duration and retreat of the rain are decisive in the agricultural production. Seasonal rainfall has a strong effect on the way of life of people particularly their outdoor activities.

The major factor controlling the climate of West Africa is Inter Tropical Discontinuity (ITD). In West Africa, the ITD assumes its northernmost position around latitude 20°N in August. This marks the height of the rainy season in West Africa with virtually the whole region under the influence of the moist southwesterly air mass from the Atlantic Ocean (Fig. 11).

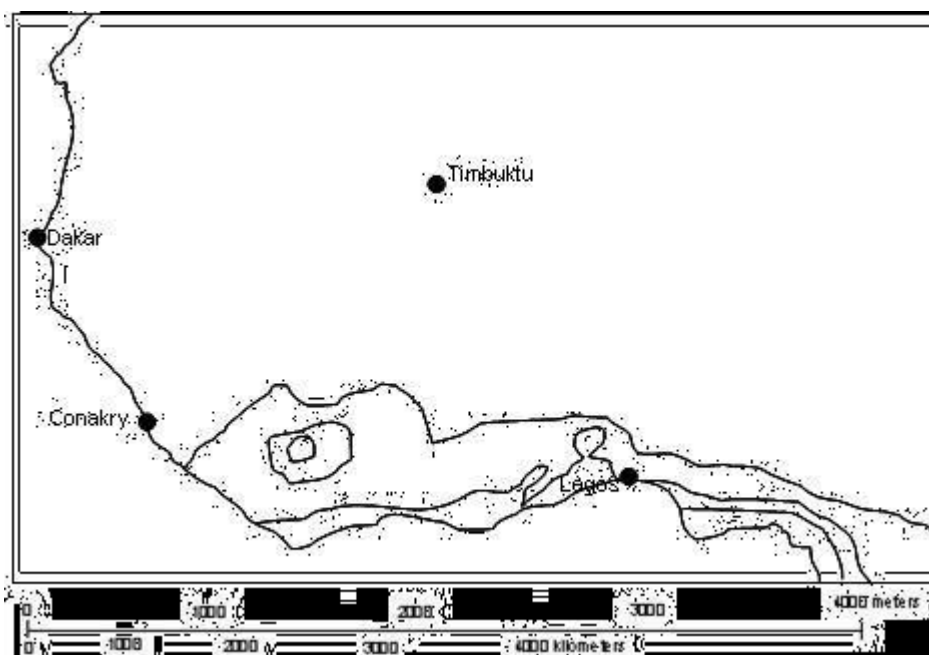

Fig. 11: February rainfall over West Africa (inches)

Source: Ayoade, 2002

The ITD attains its southernmost position around latitude 6°N in January. This represents the peak of the dry season with the whole of West Africa except the coastlands coming under the influence of the dry north easterlies from the Sahara Desert (Fig 12).

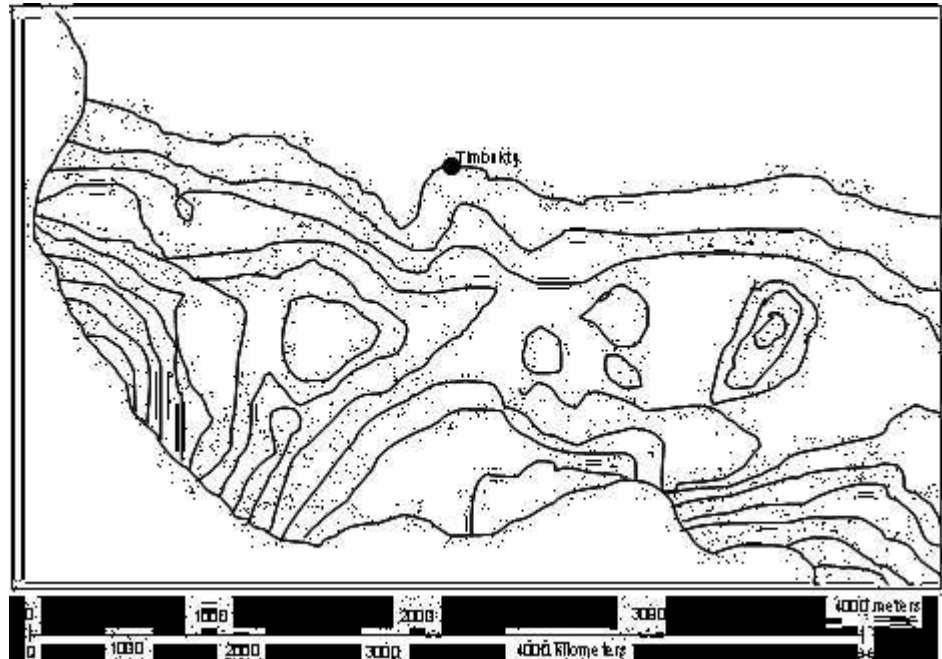

Fig. 12: August rainfall over West Africa (inches)

Source: Ayoade, 2002

The coastal region of West Africa (areas around Calabar) is a continuously rainy area, where there is some seasonal variation in rainfall but where no real dry season occurs. This is followed by a region where two rainy seasons and two dry periods alternate. The length and intensity of the two major rainy and two dry seasons are rarely the same. In the northern part of West Africa only a short rainy season and a long dry season occur.

Rainfall decreases both in duration and amount from the coast to the interior except where altitudinal effects create islands of higher rainfall (e.g. Jos Plateau). The coastal areas receive over 4000mm spread over 8-10 months while the extreme north receives less than 250mm spread over 3 to 4 months.

4.0 CONCLUSION

Evaporation is the source of moisture in the atmosphere and eventually rainfall. Rainfall is the source of moisture for agricultural production particularly in the tropics.

5.0 SUMMARY

In this unit we have learnt that:

1. Evaporation involves the change of state of water from liquid or solid into gas. Evaporation may occur either from a free water surface or bare ground. Water loss from transpiration in combination with evaporation is termed evapotranspiration. If moisture is not limiting at the evaporating surface, evaporation and evapotranspiration occurs at the maximum rate possible; and this is termed potential evapotranspiration. Evaporation and evapotranspiration that occur when water is not always available is termed actual evapotranspiration.
2. In the tropics, seasonal variation in rainfall is an important factor which controls the agricultural calendar.
3. Seasonal rainfall has a strong effect on the way of life of people, particularly their outdoor activities.
4. The major factor controlling West Africa's climate is the ITD.

6.0 TUTOR-MARKED ASSIGNMENT

1. Write short notes on the following:
 - a. Evaporation
 - b. Evapotranspiration
 - c. Actual evapotranspiration
 - d. Potential evapotranspiration.
2. Comment on the importance of ITD.
3. Discuss the effect of the radiation of the earth on the global distribution of solar radiation.
4. Explain the seasonal variations in daylight in the world.
5. Why is there no cold season in the tropics?

7.0 REFERENCES/FURTHER READING

- Ayoade, J.O. (1983). *Introduction to Climatology for the Tropics* John ChiChester: Wiley and Sons.
- Nieuwolts, S. (1977). *Tropical Climatology: An Introduction to the Climates of the Low Latitudes*. ChiChester: John Wiley and Sons.
- Ojo, O. (1977). *The Climates of West Africa*. Ibadan: Heinemann Educational Books.
- Ojo, O. *et al* (2001). *Fundamentals of Physical and Dynamic Climatology*. Lagos: SEDEC Publishers.
- Strahler, A.N. and Strahler, A.H (1973). *Environmental GeoScience: Interaction between Natural Systems and Man*. ChiChester:John Wileys and Sons.

MODULE 3

Unit 1	Equipment and Maintenance of Standard Meteorological Stations
Unit 2	Measurement of Air Pressure, Wind Speed, Wind Direction, Radiation and Sunshine Duration
Unit 3	Measurement of Evaporation and Evapotranspiration and Maintenance of a Standard Meteorological Station
Unit 4	Climate and Agriculture in the Tropics I
Unit 5	Climate and Agriculture in the Tropics II

**UNIT 1 EQUIPMENT AND MAINTENANCE OF
STANDARD METEOROLOGICAL STATIONS**

CONTENTS

1.0	Introduction
2.0	Objectives
3.0	Main Content
3.1	Categories of Weather Stations
3.2	Weather Measurement
3.2.1	Rainfall
3.2.2	Air Temperature
3.2.3	Humidity
4.0	Conclusion
5.0	Summary
6.0	Tutor-Marked Assignment
7.0	References/Further Readings

1.0 INTRODUCTION

A weather station otherwise known as a meteorological station or meteorological enclosure is a place where all elements of weather are measured and recorded. In dimension, it measures 10 metres by 6 metres. It should be located on a level ground covered with short grasses. Furthermore, the station should not be sited on or close to a hill, in a depression or on steep slope, near buildings or tall trees. The station is also usually fenced around with wire gauze for the security of the instruments and to ensure free air circulation. Based on the number of elements measured or observed and the frequency of observation of these elements, four categories of weather stations are recognised.

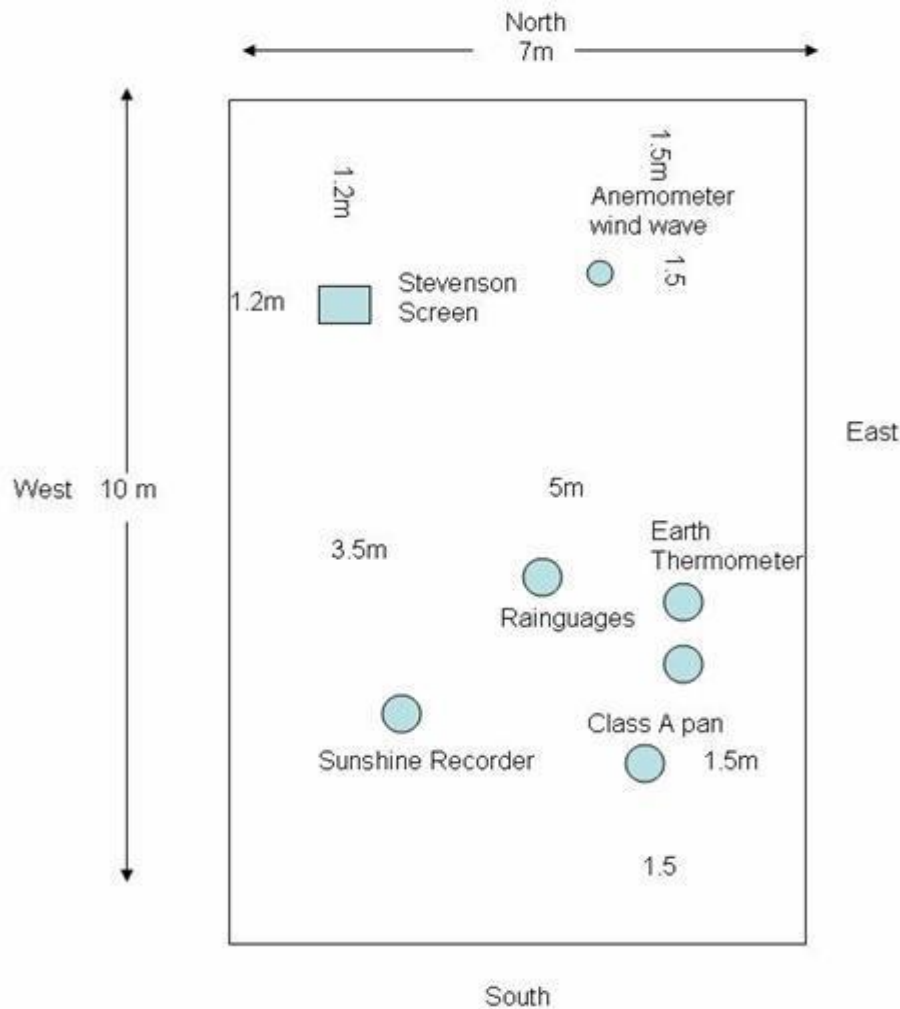

Fig. 13: Layout of a Weather Station (Source: Ayoade, 2002)

2.0 OBJECTIVES

At the end of this unit, you should be able to:

- describe the layout of a weather station
- recognise the equipment for measuring rainfall, air temperature and humidity
- measure rainfall, air temperature and humidity.

3.0 MAIN CONTENT

3.1 Categories of Weather Stations

We have the following categories of weather stations:

1. **Rainfall stations:** These are stations manned by part-time observers who take daily readings of rainfall only. In the strictest sense of the term these are not weather stations, as the only weather element measured is rainfall.

2. **Climatological stations:** These stations are also manned by part-time observers but in addition to measuring daily rainfall, they make once or twice daily instrumental observations of air temperature and humidity.
3. **Agroclimatological stations:** These are stations where daily instrumental observations of temperature and humidity, as well as soil temperatures of various depths are made once or twice. Other elements which are measured only once daily include rainfall, wind speed and direction, evaporation, sunshine duration and radiation. They are manned by part-time observers.
4. **Synoptic station:** These are stations manned by full-time professional observers. Continuous weather monitoring and hourly instrumental observation are maintained here. The main climatic elements observed include temperature, humidity, pressure, rainfall, duration of sunshine, cloud amount and wind speed and direction.

3.2 Weather Measurement

Elements of weather are observed and measured by weather instruments which are kept within the confines of weather stations. Weather instruments may be manual or self-recording (autographic). The autographic instruments provide continuous measurements of weather elements over a period of time, usually 24 hours. Autographic instruments are more expensive than manual instruments. The general procedures for the measurements of the major weather elements are discussed here.

3.2.1 Rainfall

Rainfall is measured by a rain gauge. A rain gauge consists of a copper cylinder with a metal funnel which leads into a smaller copper container or a glass bottle. The hole in the funnel that leads down to the container is very small so that evaporation of the collected rain is minimised. The gauge should be at least 30cm above the ground and firmly fastened to avoid splashing. Rainfall falling in the funnel trickles into the jar below and at the end of a 24-hour period this is poured into a graduated measuring cylinder which is tapered at the bottom to enable very small amounts (such as 0.25mm) to be measured accurately. The reading should be done at eye-level and to an accuracy of up to 0.1cm.

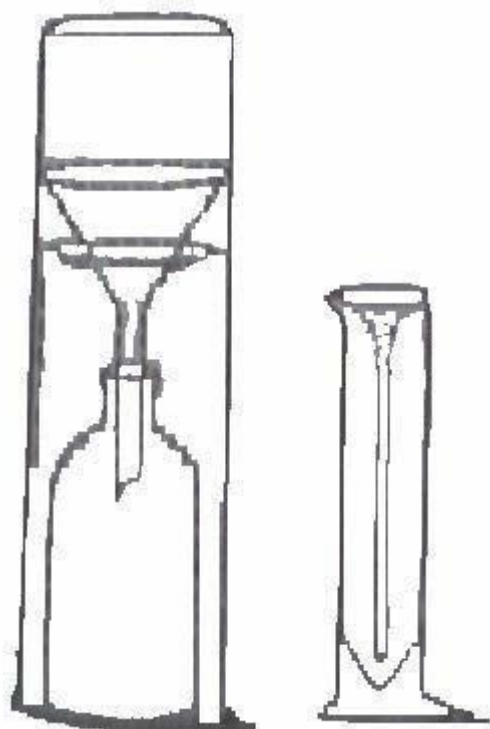

Fig. 14: Rainguages

Rainfall is generally stated in units of inches, millimeters and centimeters that fall per unit of time. For instance, 20mm of rainfall would cover the ground to a depth of 20mm, provided that none is lost by runoff evaporation or sinking into the ground. For meteorological recordings, a rain-day is reckoned by a period of 24 hours with at least 0.25mm of rain recorded.

There are different types of autographic rain gauges, depending on the type of operating mechanism; they include the tilting siphon, the tipping bucket and the weighing collector system (W.M.O 1970). The most popular of these rain gauges is the tilting siphon autographic rain gauge. It contains a collecting chamber fitted with a float. When the chamber fills up as rain falls, the float rises and a pen attached to the top traces a graph on a chart fixed to a cylindrical drum driven by clock wave. After the chamber is filled, it tilts over on its pivot and the contents siphon out of the gauge. The float then returns to its original level and the pen rests on the base of the chart. The chamber fills up again as the rain continues to fall and the process is repeated until the rain stops. One complete cycle measures 5mm of rainfall.

3.2.2 Air Temperature

Air temperature is measured manually with the aid of maximum and minimum thermometers and autographically by a thermograph.

Each weather station has a Stevenson screen in which the thermometers are kept. They are maximum and minimum thermometers, wet bulb thermometer and dry bulb thermometer. The screen is built to provide shade under which the shade temperature of the air can be measured. It is a wooden box whose four sides are louvered to allow adequate ventilation. The roof is made of double boarding to prevent the sun's heat from reaching the inside of the screen while the white paint further improves the insulation against solar radiation. It is placed on a stand, about 121cm (4ft) above the ground level.

The maximum thermometer is a mercury-in-glass thermometer which contains a small glass index. When the temperature rises the mercury expands and pushes the index along the tube. When the temperature falls, the mercury contracts leaving behind the index. The maximum temperature is read on the scale at the end of the index nearer the mercury.

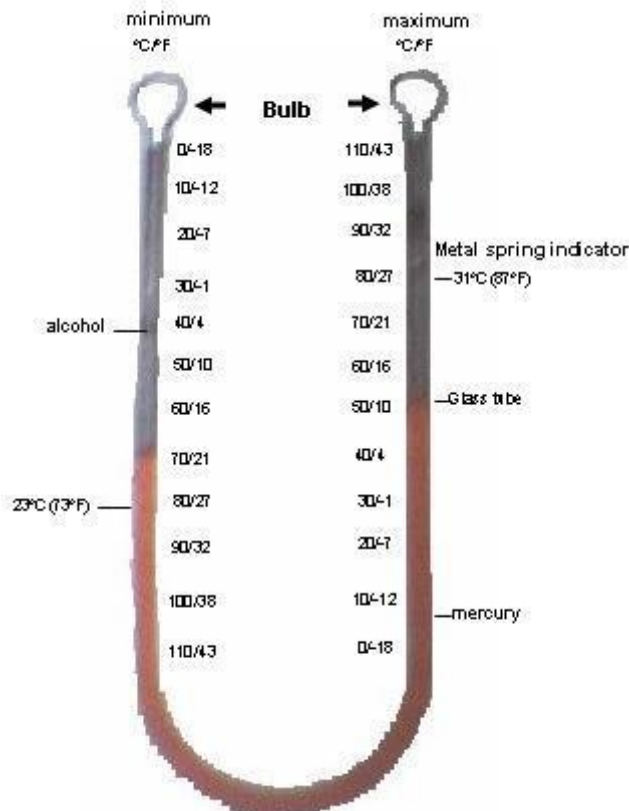

Fig. 15: Maximum and minimum thermometers

The minimum thermometer is an alcohol in-glass thermometer in which when the temperature rises, the alcohol expands and flows past the index and when the temperature falls, the alcohol contracts and pulls the index

along the tube. The end of the index nearer the meniscus shows the minimum temperature. The instrument is reset by tilting or by using a magnet to draw back the index to the mercury. The maximum and minimum thermometers are used at weather stations to measure the highest and lowest temperatures within the day respectively. The air temperature at any given time can be read off an ordinary mercury in-glass thermometer with or without an index.

Continuous measurement of air temperature can be done with the aid of a self-recording thermometer known as a thermograph.

3.2.3 Measurement of Humidity

There are various measures of humidity (i.e. the water vapour content of the atmosphere). These include, as earlier discussed, relative humidity, absolute humidity, specific humidity, humidity mixing ratio, vapour pressure and dew point temperature. Relative humidity is however, the most commonly used measure of humidity, perhaps because it is easy to compute using the wet and dry bulb thermometer. The instrument for measuring relative humidity is the hygrometer, which comprises wet- and dry bulb thermometers placed side by side in the Stevenson screen. The dry bulb is in fact the ordinary thermometer that measures shade temperature (T_d). The wet bulb thermometer has its bulb covered with muslin which is perpetually dipped in a reservoir of distilled water. When air is saturated, evaporation, which produces a cooling effect, takes place from the wet muslin. The wet bulb therefore always shows lower reading (T_w) than the dry bulb. The difference between the two readings ($T_d - T_w$) is known as the wet bulb depression. The drier the atmosphere is the greater this difference. Psychometric tables are used to obtain values, vapour pressure, dew point and relative humidity from readings of dry and wet bulb thermometers. A simplified version of the psychometric tables is given below.

Table 11.1: Psychrometric tables – Relative humidity

Air Temp. F	Depression of wet bulb thermometer, F																																			
	1	2	3	4	5	6	7	8	9	10	11	12	13	14	15	16	17	18	19	20	21	22	23	24	25	26	27	28	29	30	31	32	33	34	35	
0	67	33	1																																	
5	73	46	20																																	
10	78	56	34	12																																
15	82	64	46	29	11																															
20	85	70	55	40	26	12																														
25	87	74	62	49	37	25	13	1																												
30	89	78	67	56	46	36	26	16	6																											
35	91	81	72	63	54	45	36	27	19	10	2																									
40	92	83	75	68	60	52	45	37	29	22	15	7																								
45	93	86	78	71	64	57	51	44	38	31	25	18	12	6																						
50	93	87	80	74	67	61	55	49	43	38	32	27	21	16	10	5																				
55	94	88	82	76	70	65	59	54	49	43	38	33	28	23	19	11	9	5																		
60	94	89	83	78	73	68	63	58	53	48	43	39	34	30	26	21	17	13	9	5	1															
65	95	90	85	80	75	70	66	61	56	52	48	44	39	35	31	27	24	20	16	12	9	5	2													
70	95	90	86	81	77	72	68	64	59	55	51	48	44	40	36	33	29	25	22	19	15	12	9	6	3											
75	96	91	86	82	78	74	70	64	62	58	54	51	47	44	40	37	34	30	27	24	21	18	15	12	9	7	4	1								
80	96	91	87	83	79	75	72	68	64	61	57	54	50	47	44	41	38	35	32	29	26	23	20	18	15	12	10	7	5	3						
85	96	92	88	84	81	77	73	70	66	63	59	57	53	50	47	44	41	38	36	33	30	27	25	22	20	17	15	13	10	8	6	4	2			
90	96	92	89	85	81	78	74	71	68	65	61	58	55	52	49	47	44	41	39	36	34	31	29	26	24	22	19	17	15	13	11	9	7	5	3	
95	96	93	89	86	82	79	76	73	69	66	63	61	58	55	52	50	47	46	42	39	37	34	32	30	28	25	23	21	19	17	15	13	11	10	8	
100	96	93	89	86	83	80	77	73	70	68	65	62	59	56	54	51	49	46	44	41	39	37	35	33	30	28	26	24	22	21	19	17	15	13	12	
105	97	93	90	87	84	81	78	75	72	69	66	64	61	58	56	53	51	49	46	44	42	40	38	36	34	32	30	28	26	24	22	21	19	17	15	
110	97	93	90	87	84	81	78	75	73	70	67	65	62	60	57	55	52	50	48	46	44	42	40	38	36	34	32	30	28	26	25	23	21	20	18	
115	97	94	91	88	85	82	79	76	74	71	69	66	64	61	59	57	54	52	50	48	46	44	42	40	38	36	34	33	31	29	28	26	25	23	21	
120	97	94	91	88	85	82	80	77	74	72	69	67	65	62	60	58	55	53	51	49	47	45	43	41	40	38	36	34	33	31	29	28	26	25	23	
125	97	94	91	88	86	83	80	78	75	73	70	68	66	64	61	59	57	55	52	51	49	47	45	44	42	40	38	37	35	33	32	30	29	27	26	
130	97	94	91	89	86	83	81	78	76	73	71	69	67	64	62	60	58	56	54	52	50	48	47	45	43	41	40	38	37	35	33	32	30	29	28	

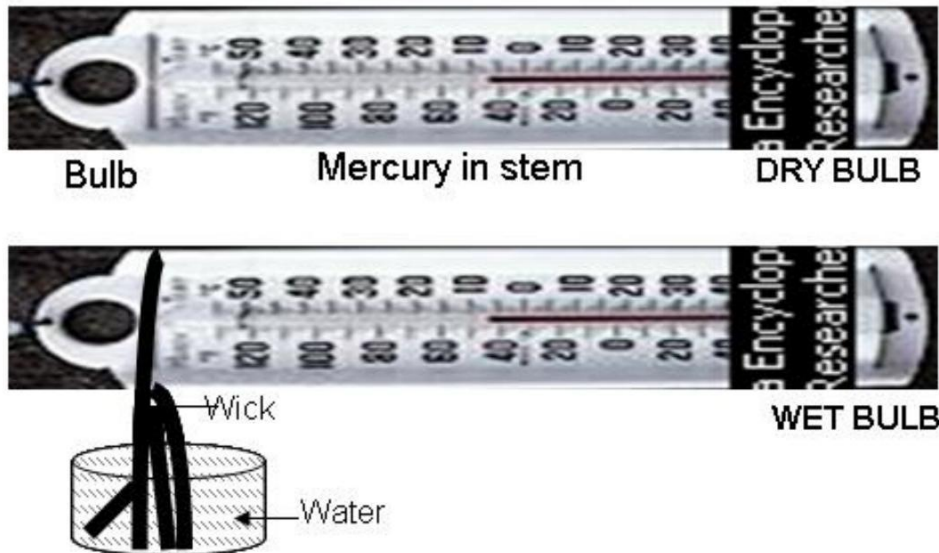

Fig. 16: Hygrometer (Dry and Wet bulb thermometer)

4.0 CONCLUSION

There are four categories of weather stations. Weather equipment is kept in weather stations. Thermometers and dry and wet bulb thermometers are kept in the Stevenson screen which in turn is placed in a weather station.

5.0 SUMMARY

In this unit we have learnt that:

1. A weather station is a place where all weather elements are measured and recorded.
2. Four categories of weather stations are recognised – rainfall stations, climatological stations, agroclimatological stations and synoptic stations.
3. The dimension of a weather station is 6x10m.
4. Rain gauges (both manual and self-recording) are used in measuring rainfall.
5. Thermometers (both manual and self recording) are used in measuring temperature.
6. Dry and wet bulb thermometers are used to measure humidity.

6.0 TUTOR-MARKED ASSIGNMENT

1. Explain the main features of rain gauges and how the amount of rain is measured with the equipment.
2. Explain how you will set up a standard meteorological station.

7.0 REFERENCES/FURTHER READING

- Areola, O. (1999). *Certificate Physical and Human Geography for Senior Secondary Schools*. Ibadan: University Press Plc.
- Ayoade, J.O. (1983). *Introduction to Climatology for the Tropics*. ChiChester: John Wiley and Sons.
- Ayoade, J.O. (2002). *Introduction to Agroclimatology*. Ibadan: Vantage Publishers.
- Bunnet, R.B. (1973). *General Geography in Diagram*. London: Longman.
- Nieuwolt, S (1977). *Tropical Climatology. An Introduction to the Climates of the Low latitudes*. ChiChester: John Wiley and Sons.
- Ojo, O. (1977). *The Climates of West Africa*. Ibadan: Heinemann Educational Books.
- Ojo,O.*et al.* (2001) .*Fundamentals of Physical and Dynamic Climatology*. Lagos: SEDEC Publishers.

UNIT 2 MEASUREMENT OF AIR PRESSURE, WIND SPEED, WIND DIRECTION, RADIATION AND SUNSHINE DURATION

CONTENTS

- 1.0 Introduction
- 2.0 Objectives
- 3.0 Main Content
 - 3.1 Measurement of Air Pressure
 - 3.2 Measurement of Wind Speed
 - 3.3 Measurement of Wind Direction
 - 3.4 Measurement of Radiation
 - 3.5 Measurement of Sunshine Duration
- 4.0 Conclusion
- 5.0 Summary
- 6.0 Tutor- Marked Assignment
- 7.0 References/Further Readings

1.0 INTRODUCTION

Weather observation and measurements started in Unit 11 and continues in this unit.

2.0 OBJECTIVES

At the end of this unit, you should be able to:

- recognise the equipment for measuring air pressure, wind speed, wind direction, radiation and sunshine duration
- measure air pressure, wind speed, wind direction, radiation and sunshine duration.

3.1 Measurement of Air Pressure

Air has weight and the weight of the vertical column of air is measured by barometers. The instrument which measures air pressure is called a barometer. There are various types of barometers. They are the mercury barometer, the aneroid barometer, the barograph and altimeter.

1. The mercury barometer: The principle which operates the mercury barometer is the balancing of the column of air against a column of mercury in a scaled glass tube. Fluctuations in air pressure produce corresponding differences in the height of the mercury and a graduated vanier is mounted along the tube to facilitate accurate reading to a thousandth of an inch. At sea level,

the atmosphere balances a column of mercury 29.29 inches. In general the mercury barometer is large and cumbersome to carry about but it is very accurate and is used in many weather stations.

2. The aneroid barometer measures pressure using the principle of sylphon cells, which is partially evacuated metal wefer. When pressure in the outside air increases, the cell tends to “collapse”; when pressure decreases, the cell expands. These fluctuations with pressure changes are mechanically linked to an indicator or a calibrated dial. The dial is commonly calibrated in inches of mercury. Although the aneroid barometer is less reliable, it is more compact, portable and convenient to use on the field.
3. The altimeter is an altitude barometer. The principle is the same as that of the aneroid barometer. The chief difference lies in the fact that barometric scales are calibrated in terms of atmospheric pressure, whereas, altimeters are calibrated in feet or metric height units.
4. The barograph: Atmospheric pressure can also be measured with the aid of a self-recording barometer known as a barograph. The most commonly used barograph employs the sylphon cells. Sylphon cells activate pen arm which moves the ink record.

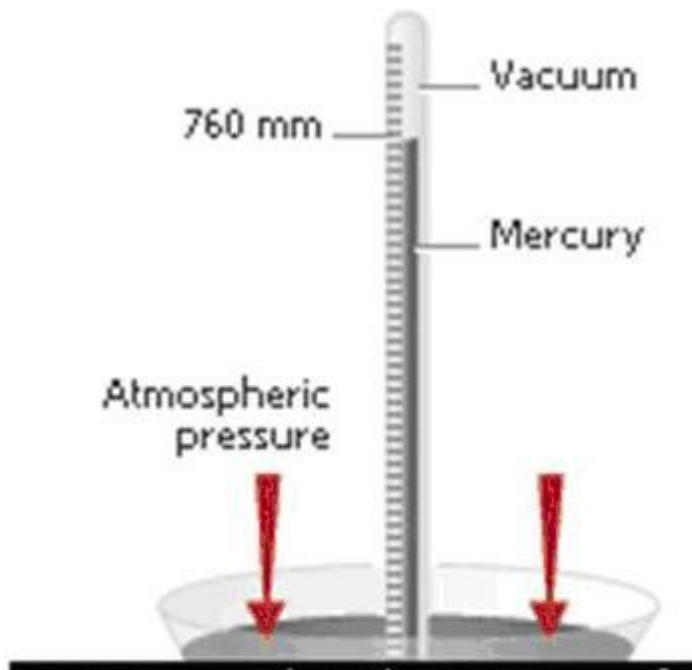

Fig. 17: Mercurial barometer

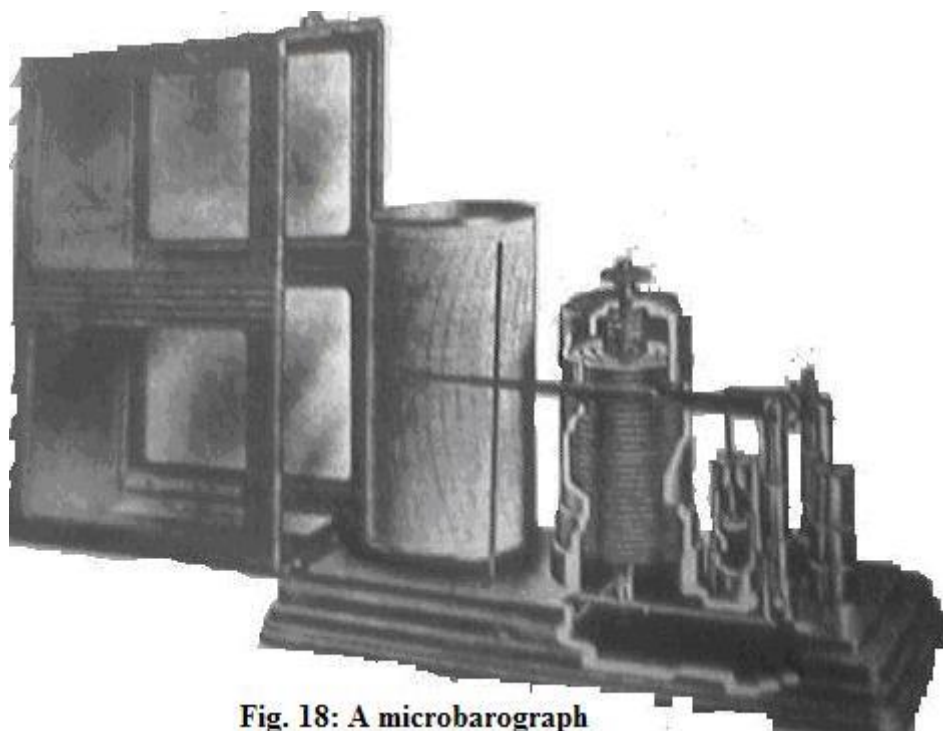

Fig. 18: A microbarograph

3.2 Measurement of Wind Speed

Wind speed is measured by a cup anemometer which consists of three or four cups, conical or hemispherical in shape mounted symmetrically about vertical axis.

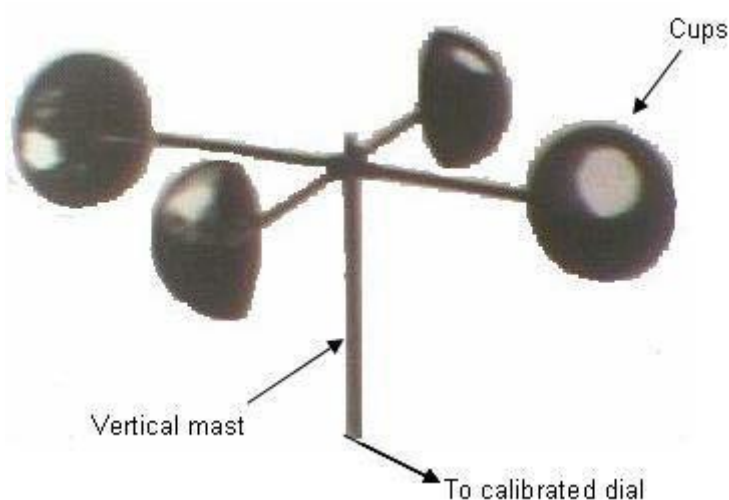

Fig. 19: Wind anemometer

The metal cups which are fixed to the ends of the arms rotate according to the prevailing wind speed. In the cup generator anemometer the rotating cups are made to generate voltage, which registers on a dial calibrated in knots, miles or kilometres per hour. In the cup-counter anemometer the integrated flow of the air in miles or kilometres is registered on a counter. In the latter case, wind speed is obtained by dividing in wind run between two observation times by the intervening

period of time, usually 24 hours. A self-recording anemometer which produces a continuous record of wind velocity overtime is called an anemograph.

3.3 Measurement of Wind Direction

Wind direction is observed with the aid of a wind vane which consists of a rotating arm pivoted on a vertical shaft. The arrow of the wind vane always points in the direction from which the wind blows and the wind is named after the direction.



Fig. 20: Wind vanes

3.4 Measurement of Insolation

A number of instruments are available for measuring the different components of the earth’s radiation balance, the equation of which is in the form

$$R_n = (Q+q) (1-\sigma) + I_{\uparrow} - I_{\downarrow}$$

Where R_n is the net radiation, $(Q+q)$ is the sum of the shortwave direct (Q) and diffuse (q), solar radiation incident on the earth’s surface, I_{\uparrow} is the counter radiation from the atmosphere which is the long-wave (infrared) and I_{\downarrow} is the terrestrial radiation which is also a long-wave or infrared.

Instruments used for measuring radiation are generally expensive and therefore are not commonly used in many developing countries. The instruments fall into five basic types as follows:

1. Net Radiometers – for measuring only the net radiation.
2. Pyranometers- for measuring the total short wave radiation from the sky incident on a horizontal surface at the ground.

3. Pyrheliometers – for measuring the solar intensity or the direct beam solar radiation (Q) at normal incidence. These are the most accurate of all radiation instruments.
4. Pyrrometers – for measuring only the albedo of the surface
5. Pyrgeometers – for measuring infrared long wave radiation from the earth's surface or the atmosphere depending upon whether it is downward facing or upward facing.
6. Albedometers – for measuring only the albedo of the surface.

Measurements of some radiation components are described below.

Pyrheliometers are instruments designed for measuring the direct beam solar radiation at normal incidence, usually called solar intensity. It has a blackened receiving surface oriented perpendicular to the solar beam and is either inserted in a blackened tube or surrounded by a series of spaced diaphragms arranged in such a way that only radiation from the sun and a narrow annulus of sky is intercepted.

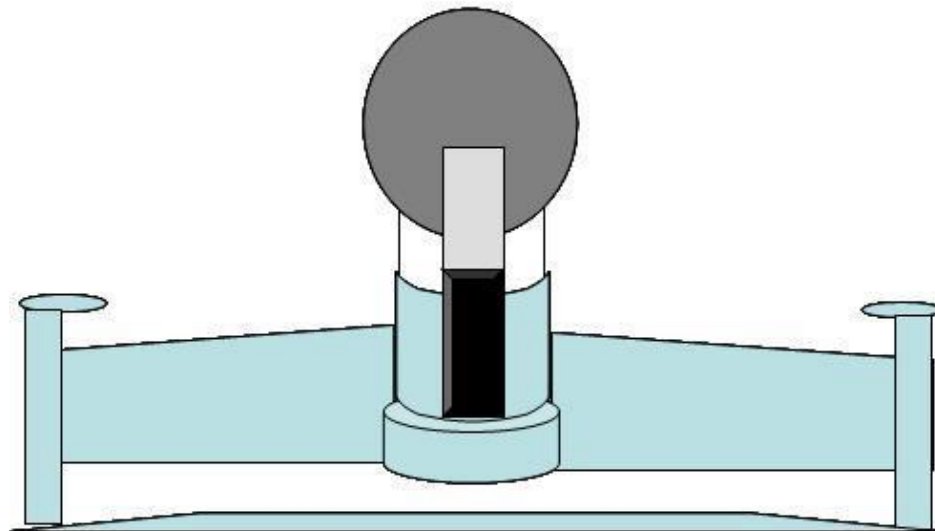

Fig. 21: Pyranometer

Pyranometers are more commonly used than pyrheliometers. They measure the total short wave radiation from the sun and sky incident on a horizontal surface of the ground (i.e. both direct and diffuse radiation). The receiver of the pyranometer is enclosed in a glass or quartz casing that must be kept clean and dry. To provide the best possible result, the pyranometer should be treated so that a shadow will not be cast on it at any time.



Fig. 22: Star Pyranometer 3.5

Measurement of Duration of Sunshine

The duration of sunshine is measured with the aid of Campbell-stokes sunshine recorder. It consists of a glass sphere which

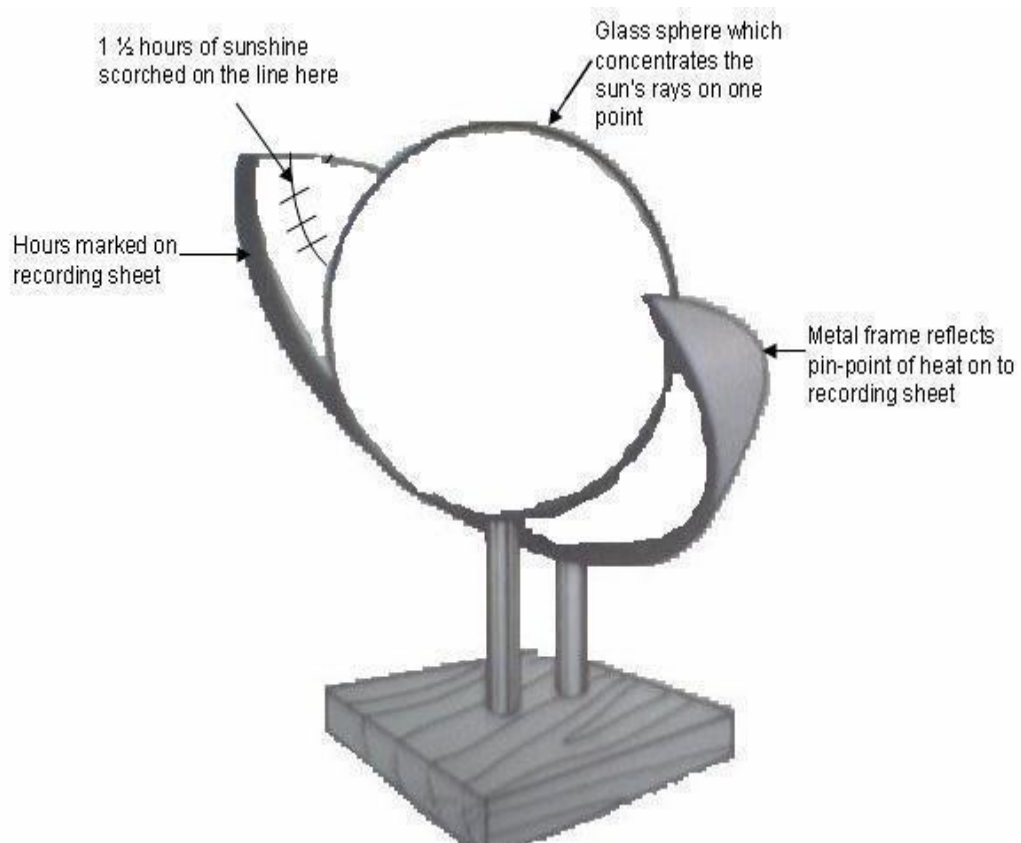

Fig. 23: Campbell-Stokes Sunshine Recorder

concentrates the sun's rays on a sensitised card graduated in hours and minutes and held in a metal half-bowl with which the sphere is concentric. The instrument is installed on a concrete pillar in the open about 1-5m above the ground. Bright sunshine leaves a trace of burnt line along the sensitised card while cloudy periods are blank. To measure the total duration of sunshine for the day, the total length of the burnt traces on the card which is graduated in hours and minutes is calculated.

3.6 Measurement of Soil Temperature

Soil temperatures are measured at various depths – 5cm, 10cm, 20cm, 50cm and 100cm. The instrument used for measuring soil temperature is known as soil thermometer. It is a mercurial thermometer with bulbs embedded in paraffin wax. The thermometer is suspended in steel tubes and inserted into the soil at various depths.

4.0 CONCLUSION

Equipment for measuring air pressure, wind speed and direction, radiation and sunshine duration have been identified in this unit. Methods of measuring the climatic elements have also been discussed.

5.0 SUMMARY

In this unit we have learnt that:

1. Various types of barometers are used for measuring air pressure.
2. Cup anemometer is the equipment used for measuring wind speed.
3. The wind vane is used for measuring wind direction.
4. Various types of radiometers are used for measuring various aspects of radiation.
5. Campbell-stokes sunshine recorder is used for measuring the duration of sunshine.

6.0 TUTOR-MARKED ASSIGNMENT

1. List all the equipment used for measuring all aspects of solar radiation and describe pyrgeometers.
2. Explain how to measure wind speed.
3. Draw an annotated diagram of the mercury barometer.

7.0 REFERENCES/FURTHER READING

Areola, O. (1999). *Certificate Physical and Human Geography for Senior Secondary Schools*. Ibadan: University Press Plc.

Ayoade, J.O. (1983). *Introduction to Climatology for the Tropics*. ChiChester: John Wiley and Sons.

Ayoade, J.O. (2002). *Introduction to Agroclimatology*. Ibadan: Vantage Publishers, Tropical Climatology: A

Bunnet, R.B. (1973). *General Geography in Diagrams*. London: Longman,

Nieuwolt, S (1977). *An Introduction to the Climates of the Low Latitudes*. ChiChester: John Wiley and Sons.

Ojo, O. (1977). *The Climates of West Africa*. Ibadan: Heinemann Educational Books.

Ojo, O. *et al.* (2001). *Fundamentals of Physical and Dynamic Climatology*. Lagos: SEDEC Publishers.

UNIT 3

**MEASUREMENT OF
EVAPORATION
AND
EVAPOTRANSPIRATION AND THE
MAINTENANCE OF A STANDARD
METEOROLOGICAL STATION**

CONTENTS

- 1.0 Introduction
- 2.0 Objectives
- 3.0 Main Content
 - 3.1 Measurement of Evaporation
 - 3.2 Measurement of Evapotranspiration
 - 3.3 Maintenance of a Standard Meteorological Station
- 4.0 Conclusion
- 5.0 Summary
- 6.0 Tutor-Marked Assignment
- 7.0 References/Further Readings

1.0 INTRODUCTION

Weather observation and measurements started in Unit 11 continue in this unit.

2.0 OBJECTIVES

At the end of this unit, you should be able to:

- recognise the equipment for measuring evaporation and evapotranspiration
- take care of a meteorological station.

3.0 MAIN CONTENT**3.1 Measurement of Evaporation**

The equipment for measuring evaporation are generally called evaporimeters. There are two basic types of evaporimeters: those in which evaporation takes place from a continuously wetted porous surface of blotting-paper, fabric or ceramic material, an example of which is the piche evaporimeter; and those in which evaporation takes place from a free water surface in tanks or pans.

The Piche Evaporimeter

The most common instrument for measuring evaporation in West Africa is the piche evaporimeter, a graduated measuring cylindrical tube

22.5cm long with an internal diameter of 11mm and an external diameter of 14mm. It has a closed and an open end. At the open end of the tube is a wetted surface (a filter paper disc) held by a spring fitted with a disc and collar. The total evaporating surface is given in centimeters. Water is supplied to the paper at the open end by a wick inking it to a small water container normally graduated in millimeters. The evaporation from the instrument is the difference between the readings of the container at the beginning and end of the period. The Piche evaporimeter is not reliable and it has been criticised as measuring the drying power of air rather than the amount of water lost by evaporation to the atmosphere. The piche evaporimeter is also kept in the Stevenson screen.

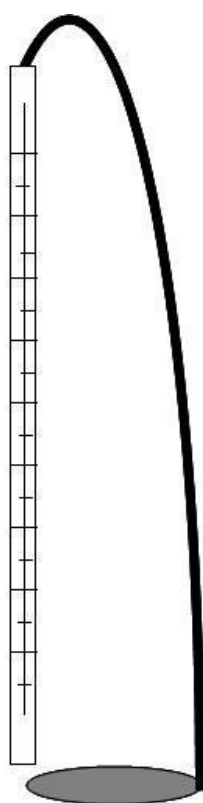

Fig. 24: Piche Evaporimeter

There are different types of evaporation pans depending on their size, shape and manner of exposure. Only the three most common ones are described here. These are the United States Weather Bureau (USWB) Class A pan, the raised tank and the sunken tank. The USWB Class A pan has been recommended for worldwide use by the WMO. It is circular with a diameter of 1206mm and 254mm deep. It is made of galvanised iron and mounted on a wooden open frame platform about 150mm above the ground. The pan is filled with water to within 51mm of the rim.

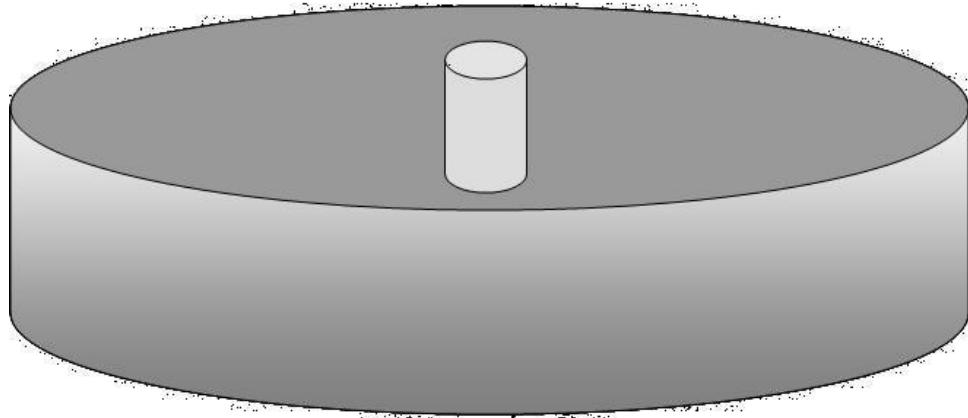

Fig. 25: Class A pan

The sunken tank is about 1829mm^2 with the water level at the ground level and a rim of 76mm protruding above the ground to prevent inflow of surface water when it rains.

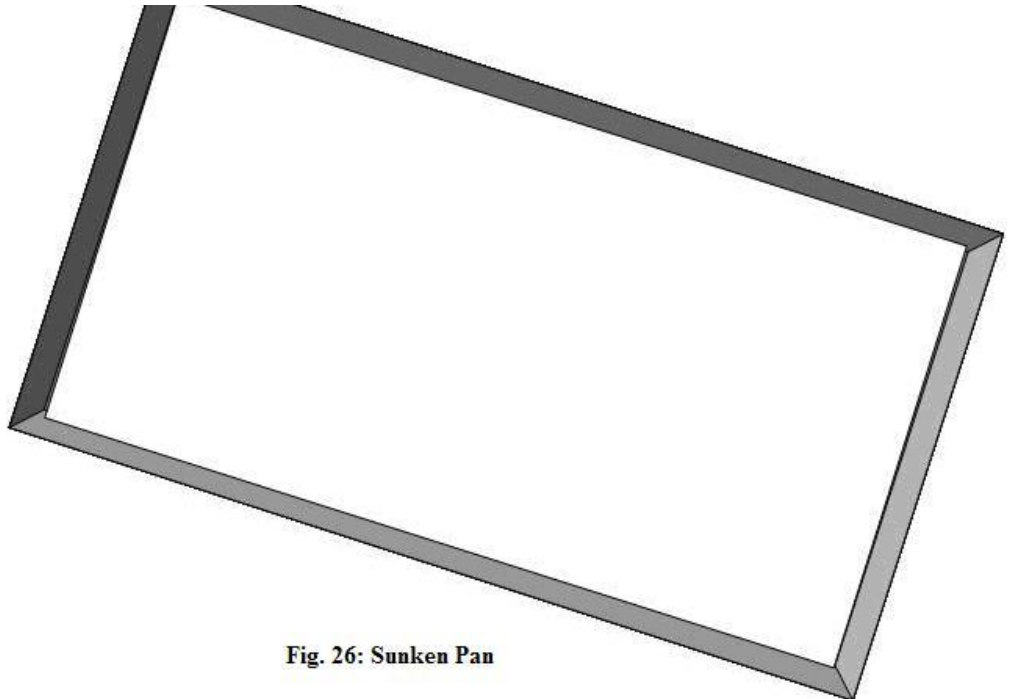

Fig. 26: Sunken Pan

A third type, the raised tank, is a rectangular tank which is 915mm by 1270mm and 432mm deep. The depth of the water in the tank is about 350mm. A wooden platform is used to raise the tank so that the water surface is about 457mm above the ground.

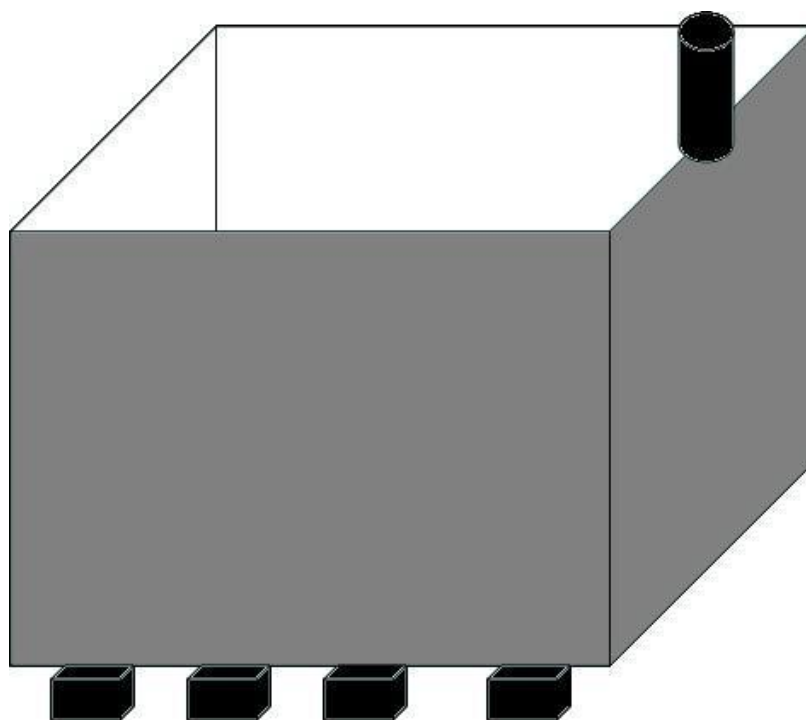

Fig. 27: Raised Tank

The principle employed in all evaporation pans to measure evaporation rates is the same: Evaporation measurements are taken by refilling the water in the tanks to a fixed level. After a period of time, which is usually 24 hours, the level of water in the pan is checked. Unless some rain has fallen during the intervening period, the level of water in the pan would have fallen owing to evaporation. The pan is reset by filling it back with water to the original level. The amount of water added to reset the pan represents the evaporation that has occurred in the intervening period. Each pan has a cup specific to it and this is used to refill the pan. When rain falls, the rain water is allowed for by adding the amount of rainfall measured in a nearby rain gauge to the amount of the apparent evaporation.

There are a number of disadvantages to pans and sunken tanks. It is difficult to detect leakage. Because of their closeness to the ground, the tanks tend to get dirty, which influences the rate of evaporation. Another problem is that rain water can splash into the tanks or overflow from them. The tanks and pans are difficult to clean. The tanks and pans about ground level may be subject to radiation from the sides and bottom, so that readings may be higher.

One other common problem with evaporation pans and tanks is the difficulty of preventing herds or stray animals from drinking water from the pan.

However, tanks or pans have the advantage of being inexpensive to install and easy to handle. They can be used throughout the life span of a crop.

3.2 Measuring of Evapotranspiration

Rates of evapotranspiration over a surface are measured by the cost of lysimeter. There are two types of lysimeter; the weighing lysimeter and the drainage lysimeter. Lysimeter are tanks buried in the ground to measure the percolation of water through the soils. They provide the most reliable and accurate method for the direct measurement of evapotranspiration provided the necessary precautions in designing, operating and sitting are taken. The installation of lysimeter in West Africa has been impossible; however, one of the reasons is that it is very expensive.

The weighing lysimeter is a rather sophisticated device consisting of a soil-filled tank, the evapotranspirometer tank, in which grass is planted. Water enters through this tank and drains through an outlet pipe into an overflow chamber and supported by a weighing mechanism.

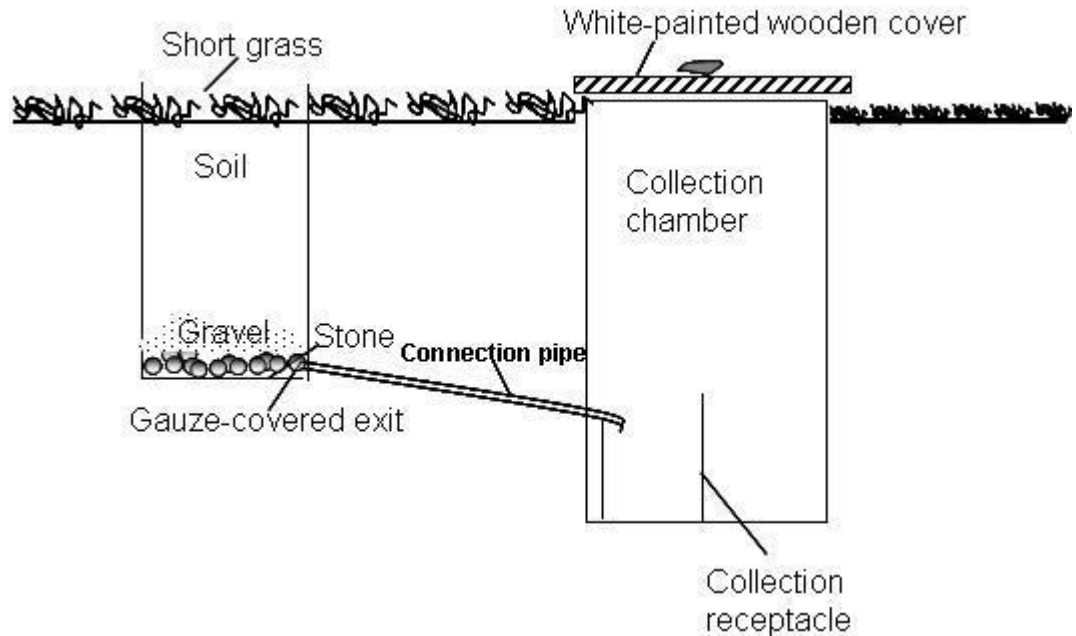

Fig. 28: Evapotranspirometer

Evapotranspiration values are obtained directly by calculating changes in the weight of the soil-vegetation system within the tank over a specified period of time, usually 24 hours, to obtain daily values of evapotranspiration. If the experimental surface is surrounded by a buffer zone with the same type of vegetation and kept moist by watering. The values of evapotranspiration obtained would be those of potential evapotranspiration. The buffer zone is necessary to ensure that

energy and drier air are not advected over the experimental plot from the surrounding. Weighing lysimeter are often used to measure actual evapotranspiration when the experimental surface and the surroundings are not kept at field capacity.

The drainage lysimeter which operates on a sample water balance basis is more widely used than the weighing lysimeter as it can be constructed. The principle on which it operates is that evapotranspiration is the difference between water input in form of rainfall and irrigation if necessary and water output in form of percolation and runoff in a soil plant system. (Chang, 1964). The drainage lysimeter is normally used to measure rates of potential evapotranspiration. There is therefore, the need to keep the tank and the surrounding area continuously moist by irrigation.

3.3 Maintenance of a Standard Meteorological Station

To ensure that observations at the meteorological stations are accurate and comparable over time, the following should be observed:

1. Buildings should not be located close to the meteorological station.
2. Big trees should not be allowed to grow around the station.
3. The grass of the meteorological station should be kept low at all times.
4. Observation of the elements should be regular and prompt.
5. Animals should not be allowed access to the station, particularly the pans and tanks; in drier areas birds and small animals use the tanks for bathing.
6. Malfunctioning equipment should be replaced promptly.

4.0 CONCLUSION

Equipment for measuring evaporation and evapotranspiration has been fully discussed in this unit. The methods of maintenance of a weather station have also been discussed.

5.0 SUMMARY

In this unit we have learnt that:

1. Evaporimeters which are of two types (piche evaporimeter, pans) are used for measuring evaporation.
2. Lysimeter which are also of two types (drainage lysimeter, weighing lysimeter) are used for measuring evapotranspiration.

3. Keeping the grass inside the weather station low, clearing the surrounding, fencing the weather station, reporting and replacing the malfunctioning equipment are some of the ways of maintaining a weather station.

6.0 TUTOR-MARKED ASSIGNMENT

1. With the aid of a diagram, describe how to measure evapotranspiration.
2.
 - a. Describe piche evaporimeter
 - b. What is its shortcoming as an instrument for measuring evaporation?
3. List ways of maintaining a weather station.
4. Explain the main features of rain gauges and how the amount of rain is measured with the equipment.
5. Explain how you will set up a standard meteorological station.
6. List all the equipment used in measuring all aspects of solar radiation and describe pyrogeometers.
7. Explain how to measure wind speed.
8. Draw an annotated diagram of a mercury barometer.
9. With the aid of a diagram, describe how to measure evapotranspiration.
10. List ways of maintaining a weather station.

7.0 REFERENCES/FURTHER READING

Areola, O. (1999). *Certificate Physical and Human Geography for Senior Secondary Schools*. Ibadan: University Press Plc.

Ayoade, J.O. (1983). *Introduction to Climatology for the Tropics*. ChiChester: John Wiley and Sons.

Ayoade, J.O. (2002). *Introduction to Agroclimatology*. Ibadan: Vantage Publishers.

Bunnet, R.B. (1973). *General Geography in Diagram*. London: Longman.

Nieuwolt, S. (1977). *Tropical Climatology: An Introduction to the Climates of the Low latitudes* ChiChester: John Wiley and Sons.

Ojo, O. (1977). *The Climates of West Africa*. Ibadan: Heinemann Educational Books.

Ojo, O. et al. (2001). *Fundamentals of Physical and Dynamic Climatology*. Lagos: SEDEC Publishers.

UNIT 4 CLIMATE AND AGRICULTURE IN THE TROPICS I

CONTENTS

- 1.0 Introduction
- 2.0 Objectives
- 3.0 Main Content
 - 3.1 General Effects of Radiation on Crop Growth
 - 3.1.1 Effects of Photoperiodism on Crop Growth
 - 3.2 General Effects of Water on Crop Growth
 - 3.3 General Effects of Humidity on Crop Growth
- 4.0 Conclusion
- 5.0 Summary
- 6.0 Tutor-Marked Assignment
- 7.0 References/Further Readings

1.0 INTRODUCTION

Of all primary economic activities pursued throughout the world agriculture is the most important and it is also highly dependent on the weather. From the review of literature, it has been amply demonstrated that agriculture being an outdoor activity is very sensitive to weather conditions. There is obviously a need to study the relations between climate and agriculture in all climates, but it is particularly important in the tropics. Climatic conditions in the tropics are generally not as favourable for agriculture as is often assumed (Nieuwolt, 1977). The luxuriant vegetation in many parts of the tropics and the rapid growth of plants have erroneously led to the belief that food can be produced with very little effort. The general relationship between climate and agriculture will be discussed below.

2.0 OBJECTIVES

At the end of this unit, you should be able to:

- explain the general effects of radiation on crop growth
- explain what photoperiod and photoperiodism are and how they influence crop distribution
- explain the general effects of moisture on crop growth.

3.0 MAIN CONTENT

3.1 General Effects of Radiation on Crop Growth

The relations between solar radiation and agriculture are primarily illustrated by two processes: photo-energy (photosynthesis) processes and photo-stimulus processes.

In general, photo-energy processes require higher radiation intensity than photo-stimulus processes. In fact photo-stimulus processes resolve themselves into two: movement processes and formative processes. Formative processes involve among other things stem elongation, leaf expansion, pigment formation, flowering in photo periodically sensitive plants which are determined by the relative length of light and dark periods to which plants are exposed.

Practically all the dry matter of higher plants originates from photosynthesis. This is the process by which plants with the aid of chlorophyll pigment utilise the energy of solar radiation to produce carbon dioxide out of water and carbohydrate. Photosynthesis is inherently an inefficient process in the utilisation of solar energy, partly because only the visible portion and spectrum is active and partly because the quantum requirement for photosynthesis is much higher than the theoretical minimum value.

The photosynthesis rate of most leaves increase with light intensity almost linearly over a narrow range. At the same light intensity, the leaves become light saturated. For a few plants, the photosynthetic rates may even decline slightly as light intensity increases beyond the saturation point.

At saturation light intensities and normal carbon dioxide concentration photosynthesis are affected by temperature because biochemical processes are limiting. Crops in the field are usually below the optimum temperature for most of the season. But the temperature of leaves in the sunlight is often higher than that of the air, sometimes by as much as 10°C and during high sun periods, the leaf temperatures may very well exceed the optimum. Gates (1965) has suggested that the midday depression in photosynthesis is often caused by the adverse effect of very high temperatures.

Plant growth depends on the excess of dry matter increase by photosynthesis over the loss by respiration. The net gain is known as net photosynthesis, or net assimilation rate. Whereas photosynthesis takes place mainly in the leaves during the day, respiration proceeds throughout the plants for the entire 24-hour period. Respiration rates

increase with temperature up to a varying maximum for different plants. For Alfalfa Thomas and Hill (1937) reported a fourfold increase in respiration rate by increasing temperature from 0⁰ to 20⁰C.

3.1.1 Effects of Photoperiodism on Crop Growth

The length of daily exposure to light is known as a photoperiod while the response of crop development to a photoperiod is called photoperiodism.

The earliest work published on this phenomenon is that of Garner and Allard (1920). Typically the photoperiod has an effect on the formation of flowers, fruits and seeds. It also influences vegetative growth, the formation of buds, tuber, the character and extent of branching, leaf shape, pigment formation, root development dormancy and death.

In their early work, Garner and Allard divided plants into three groups on the basis of their response to the photoperiod namely; long-day plants, short-day plants and day neutral plants. Long -day crops flower only under day-light less than 14 hours. Examples are wheat, mustard, oats, burkey, rye and clover. In short day- crops flowering are induced by short photoperiods of less than 10 hours. Examples are cotton, millet, corn, beans, cucumber and sweet potatoes. The day neutral crops can form the flower buds under any period of illumination. Examples are tomato and carrot. Later Allard (1938) added the fourth group which is designated as intermediate. The intermediate crops flower at a day length of 12 -14 hours but are inhibited in reproduction by day lengths either above or below this duration.

Photoperiodism is an important factor in the natural distribution of plants. In general plants that have originated in low latitude require short- day for flowering while those from high latitudes are long- day plants. When the latter are moved to low latitudes they will not produce blossom. When the low latitudes plants are grown in high latitudes they will continue to grow vegetatively until they are killed by frost.

3.2 General Effects of Water on Crop Growth

The three groups of plants have been distinguished on the basis of their water needs:

Hydrophytes – they normally grow in water or swamps, examples of which are mangrove and paddy rice.

Mesophytes – most field crops belong to the mesophyte group. This group of plants can be further divided into true mesophyte – plants that

will wilt after losing 25% of their water content and xerophytes mesophytes which include those that will wilt after losing 25-50% of their water content.

.Xerophytes –they are capable of enduring even more severe drought. They wilt permanently after losing 50-75% of their water content.

This classification provides a primary approximation of crops adaptation and distribution in various moisture regimes. However it is too crude to serve as a useful guide for irrigation and other cultural practices. For those purposes, it is essential to have an understanding of the various physiological plant responses to water. Almost every process occurring in plant is affected by water. Water is the major constituent of the physiologically active plant tissue; a reagent in photosynthesis and hydrolytic such as starch digestion; the solvent in which salt, sugar and other solutes move from cell to cell and organ to organ; and an essential element of the maintenance of plant turgidity necessary for cell enlargement and growth.

It is not, however, easy to establish a relationship between water stress and the various aspects of crop function. The relationship varies with crop characteristics, stages of soil development, and climatic conditions. Water deficiency not only reduces the yield but also changes the pattern of growth. In general, effective rooting depth decreases as the soil moisture level increases. Roots developed under limited moisture conditions are finer and have more and longer branches than roots developed under favourable moisture conditions. The ratio of root to shoot usually is increased by water stress. Leaf area is often reduced but leaf thickness is increased.

Water deficit in crop has a profound effect in the rate of photosynthesis because dehydrated protoplasm has lowered photosynthesis capacity. Indirectly, once the leaf loses its turgidity, the stomata guard cell close, thus preventing any further intake of carbon dioxide for photosynthesis.

In general the respiration rate of crops tends to increase as moisture decreases. This change is however, much smaller than the accompanying changes in photosynthesis.

Soil moisture which is an important source of moisture to crops is determined by rainfall, evaporation rate and soil characteristics.

The supply of soil moisture may vary from wilting point when no water is available for crop use to field capacity when the soil is fully saturated with moisture but is well drained. In a water logged condition (i.e. when all the soil pores are completely filled with water), free movement of air

within the soil is impeded and compounds toxic to the roots of crops may be formed. At the opposite end is the condition of drought in which the amount of water required for evapotranspiration exceeds the amount available in the soil. Drought condition makes crops wilt and eventually die. Hence, too little or too much water is not good for agriculture.

In the tropics where the temperatures are high throughout the year and the rates of evapotranspiration are constantly high, the role of moisture in crop production cannot be overemphasised. Apart from this, over most of the tropics rainfall is highly seasonal and varies in amount from one year to another.

3.3 General Effects of Humidity on Crop Growth

Compared with most other climates, relative humidities are generally high in the tropics and this is the case during the rainy season. High humidity of the air has been found to have some beneficial effects on plant growth, because many plants can absorb moisture directly from the air and the rate of photosynthesis generally increases with humidity (Baker, 1965). High relative humidity also lowers the rate of transpiration thereby reducing the water requirements of crops while evaporation losses from the soil are also less than under dry conditions. Generally, crop yields increase with increasing relative humidity (Arkley, 1963).

4.0 CONCLUSION

This unit shows clearly that weather and climate affect all aspects of crop growth and development from germination to harvesting.

5.0 SUMMARY

In this unit we have learnt that:

1. Solar radiation influences crop growth and development in the following ways – stem elongation, leaf expansion, pigment formation, flowering in photo periodically sensitive plants, yield and crop distribution.
2. Water influences crop growth and development as follows:- distribution of crops, yield, major constituent of the physiologically active plant tissue, a reagent in photosynthesis and hydrolytic, solvent in which salts, sugar and other solutes move from cell to cell and organ to organ, an essential element of maintenance of plant turgidity. Water deficit lowers

photosynthesis, increases respiration and reduces yield, causes wilting and eventually death.

3. High humidity generally lowers transpiration, thereby reducing the water requirements of crops, and increases photosynthesis and yield.

6.0 TUTOR-MARKED ASSIGNMENT

1. Discuss the various ways in which solar radiation influences crop growth and development
2. Moisture rather than temperature is the most important control of agriculture in the tropics. Explain.

7.0 REFERENCES/FURTHER READING

Ayoade, J.O. (1983). *Introduction to Climatology for the Tropics*.
ChiChester: John Wiley and Sons,

Ayoade, J.O. (2002). *Introduction to Agriculmatology*. Ibadan: Vantage Publishers.

Bunnet, R.B. (1973). *General Geography in Diagram*. London: Longman.

Nieuwolt, S. (1977). *Tropical Climatology: An Introduction to the Climates of the Low Latitudes* ChiChester: John Wiley & Sons.

Ojo, O. (1977). *The Climates of West Africa*. Ibadan: Heinemann Educational Books.

Ojo, O. *et.al.* (2001). *Fundamentals of Physical and Dynamic Climatology* Lagos: SEDEC Publishers.

UNIT 5 CLIMATE AND AGRICULTURE IN THE TROPICS II

CONTENTS

- 1.0 Introduction
- 2.0 Objectives
- 3.0 Main Content
 - 3.1 General Effects of Temperature on Crop Growth
 - 3.2 Agriculture, Pests and Diseases
 - 3.3 Agriculture and Irrigation
 - 3.4 Climate – Livestock Relationships
- 4.0 Conclusion
- 5.0 Summary
- 6.0 Tutor-Marked Assignment
- 7.0 References/Further Readings

1.0 INTRODUCTION

In this unit, we will examine the ways in which temperature influences crop growth and development. We will also examine how climate indirectly influences crop growth through its effects on pest and diseases and water supply

2.0 OBJECTIVES

At the end of this unit, you should be able to:

- explain the effects of temperature on crop growth
- explain the relationship between climate, pests and diseases and crop growth.

3.0 MAIN CONTENT

3.1 General Effects of Temperature on Crop Growth

Temperatures are of course, closely correlated with insolation and it is therefore not always possible to separate the effects of these two factors on plant life. It is however, certain that most physical and chemical processes in crops are strongly affected by temperature conditions. Every species has an optimum temperature range of which growth and development proceed with maximum intensity and speed. For most crops the cardinals range from 5°C – 6°C . Temperatures below 6°C are injurious to most crops while the upper limit for most crops ranges from 50°C to 60°C . Low temperatures kill or damage crops. Prolonged temperatures above freezing retard crop growth and may even kill those

crops adapted to warm conditions. Low temperature may not kill plant cells directly, but indirectly by reducing the flow of water from roots and so interfere with plant transpiration and nourishment. High temperatures are generally not as destructive to crops as low temperatures provided the moisture supply is adequate to prevent wilting and the crop is adapted to the climate zone.

The uniform temperature and its small seasonal variation characteristic of the tropics provide a wide range of choice of suitable crops in relation to temperature conditions; therefore temperatures are rarely a critical factor in tropical agriculture (Nieuwolt, 1977). As temperature conditions are frequently below optimum for most crops, there exists close a correlation between yields and temperature. It is also expressed in the varit Hoff law which states that dry matter production doubles for every rise in temperature of about 10°C . Such correlations are however, not valid for many tropical crops.

Soil temperature is another significant control of crop growth and development. At times, it is of greater ecological importance to crop life than air temperature. Soil temperature affects the germination of seed and later influences root development and the growth of the entire crop. Soil also affects the physical, chemical and biological processes in the soil that determine overall crop growth. For instance, potatoes require air temperature of between 8°C and 28°C , the optimum being 18°C .

3.2 Agriculture, Pests and Diseases

The combination of high temperatures and high humidities characteristic of tropical lowlands, carries serious drawbacks for tropical agriculture. For many tropical crops the yields are reduced both in quantity and quality by high temperatures, mainly because some diseases and pests thrive well under warm conditions. High temperatures and humidities in the tropics also create highly favourable conditions for the proliferation and growth of numerous micro-organisms and insects, which spread diseases and pests. They also encourage rapid and profuse growth of weeds and parasites which can drastically reduce yield. Losses are not limited to crops on the field; they are equally serious after harvesting and during storage and transportation.

In Nigeria, crop losses due to pests have been estimated to be of the order of 50 to 60% of total crop production (Ayoade, 2002). The periodic or seasonal nature of outbreaks of crop pests and diseases suggests that weather conditions play an important role. Favourable temperature and humidity conditions encourage the growth and development of crop pests and disease causing germs. Wind conditions

control the transport and distribution of disease causing germs and spores.

Locusts breed in the semi arid areas bordering the Sahara desert where there is enough moisture for breeding and for vegetative growth to feed the larva. Thereafter, the mature locusts with the aid of northeasterly winds fly in swarms southwards during the day when air temperatures are between 20⁰ and 40⁰C. The incidence of rosette and other diseases that attack groundnuts increases with increase in rainfall and humidity. This is one of the reasons why large scale cultivation of groundnut is limited to the drier northern region of Nigeria. Susceptibility to fungal diseases which thrive in warm, moist conditions has prevented cotton from being grown in southern Nigeria. Adejuwon (1962) demonstrated that too much rainfall reduces the number of cocoa pods per tree and increases the degree of infection by the black pod diseases in the cocoa growing areas of south- western Nigeria. The incidence of head mould that attacks sorghum has been attributed to high atmospheric humidity in Nigeria (Kassam *et. al* 1976).

3.3 Agriculture and Irrigation

Irrigation can be defined as the application of water to soil to provide moisture for crop growth. Irrigation is one of the oldest farm techniques used in supplying additional water in moisture deficient lands for crop production. This extends cultivations to the marginal lands. It also increases food production and increases yield. Irrigation is used in dry regions to which water can be taken; regions where rainfall is highly seasonal; regions where the annual rainfall is too low or too variable from year to year to allow proper crop cultivation and regions of the world where rice is grown by the aid of irrigation.

Large scale irrigation involves the construction of huge dams across rivers so that reservoirs are created to store water. Small scale irrigation involves the use of annual flooding of a river during the period of heavy rainfall in the upper parts of its valley (e.g. Nile valley, Ganges and Niger valley); the construction of tanks to store water directly from seasonal rainfall and digging boreholes from where water is pumped to wet crops or grasses or supply drinking water to animals.

In the dry tropics, a lot of water is required for irrigation. This is because the high temperature and low humidity of the areas increase the rate of transpiration, thereby increasing the water requirements of crop. Evaporation losses from soil are also high.

3.4 Crop Water Requirement

The water requirement of any given crop is determined by various factors, important amongst which are weather conditions (such as temperature, humidity, winds, sunshine) which determine the potential evapotranspiration of crops; crop water use which depends on the type of crops and the stage of development of the crops. The greater the leaf area of the crop and the more actively the crop is growing, the greater the amount of crop water requirement. The crop water requirement of crops can be determined in two major ways namely; by measuring lysimeter or evaporation pans, or by the use of formulae of which there are various types.

3.5 Crop Irrigation Requirement

Crop irrigation requirement is the portion of the water consumptive use of crops which must be supplied by irrigation to ensure optimal crop growth and development. It is the difference between crop water requirement and moisture available through precipitation and from soil moisture storage. Such crop irrigation requirement is actually the difference between potential evapotranspiration (PE) and the actual evapotranspiration (AE). It is therefore, best estimated through water budgeting techniques such as those of Thornthwaite and Mather (1957) and Penman (1949).

Calculating irrigation water requirement will help to maximise irrigation water. This will also help in regulating the release of water to crops so as not to harm the soil (avoid leaching and salination).

3.6 Climate – Livestock Relationship

Weather and climate influence livestock directly or indirectly in three important ways. First, climate conditions affect the availability of water for animal consumption and determine the type, quantity and quality of pastures available for animal feed. Second, weather and climate have direct effects on animals and their body physiologic functions. Third, weather and climate affect livestock production indirectly by determining the type of animal pests and diseases that would be prevalent in a given area.

The distribution of animals is affected by the availability and reliability of water supplies. The distribution of precipitation over a given area provides a rough guide to the availability of water in an area. Areas with little or no rainfall are deficient in water while areas of abundant rainfall have plenty of water, all things being equal. Humid climates are however not very favourable for most types of livestock because of the

numerous pests and diseases such climatic breeds. Again, climates promote forest ecosystems, whereas livestock prefer grass ecosystems, such grass ecosystems of the world as the African savanna the veldt of South of Africa, the steppes of Russia, the downs of Australia, the pampas of Argentina and the prairies of North America.

Moisture still determines the distribution of livestock within the grassland ecosystem. Areas with reliable sources of water, surface or underground, are usually well stocked with animals. In the dry savanna zone of West Africa, water is a major problem to livestock production. The problem of water shortages is most acute during the long dry season or in years of drought when the expected rain fails to fall. At such times water is provided for livestock from wells and boreholes. Watering points generally attract large numbers of animals.

The West African pastoralists react to shortage of water and feed caused by the dry season or drought in years of low rainfall in two ways. Some dispose of their stock by selling them at very low prices to reduce the number of dead animals and alleviate rationing available food amongst fewer animals. Many migrate with their animals to more favourable climate zones where more feed and water are available for their animals. For instance the Fulani cattle breeders migrate at the beginning of the dry season from the Sudano-Sahelian savanna zone. At the onset of the rain they move back to the Sudan-Sahelian savanna belt. These movements immediately raise two problems. First, the animals lose weight during the long trek southward and later northward; second, the animals are exposed to trypanosomiasis during their sojourn in the Guinea savanna zone.

In years of rain failure in the north, a lot of livestock perish. Thousands of livestock perished during the West Africa Sahel drought of 1972-1974 as a result of lack of water and many more perished in the 1982-1984 drought. Drought is indeed a major problem to livestock production in the West African savanna.

It is not only the health of animals that is affected by climate; the reproductive capacities of animals are also affected. Temperature affects animals' physiological functions and biochemical reactions within their various organs and tissues which may affect their productive capacity. It has been demonstrated that under hot conditions, dairy cows tend to produce less milk while beef cattle produce less fats and flesh. This is partly because these animals tend to reduce their intake of food when it is hot. The effect of extreme cold on animals may also reduce production. Much of the body energy is used to combat cold. Long exposure of livestock to cold may cause frost bite or even death.

Regional distribution of livestock is influenced indirectly by climate through pests and diseases. For instance, the southern part of Nigeria which has a more favourable climate and forage conditions for livestock has a lower population of livestock than the northern part. The reason is that the humid south is infested with tsetse fly that causes cattle trypanosomiasis responsible for high rates of morbidity and mortality among cattle. The drier north is free of this insect and hence free of the scourge of trypanosomiasis. In Nigeria, it has been argued that the humid southern parts of the country are as suitable as the drier northern parts for tropical cattle breed and more suitable for important temperate breed because of the lower heat on cattle in the south than in the north (Ojo, 1971).

Tsetse fly is found over most parts of Africa with the exception of the highland areas and relatively dry areas. The tsetse fly lives in the tree canopies where transpiration and shade maintain a combination of high humidity and moderately high temperatures necessary for its growth and development. Hence, only a few dwarf breeds of cattle that are resistant to trypanosomiasis thrive in humid and forested areas of Africa. However, most of Africa's cattle populations are to be found in the tsetse fly free zones of the savanna.

4.0 CONCLUSION

Climate influences crop and animal production directly through temperature and indirectly through its influence on pest and diseases. It also determines the need for irrigation.

5.0 SUMMARY

In this unit we have learnt that:

1. Temperature determines the range of choice of crops that can be produced in an area.
2. Temperature also affects most physical and chemical processes in crops, including yield.
3. Indirectly temperature creates favourable conditions for the proliferation and growth of numerous micro-organisms and insects which spread diseases and pests. Pests and diseases destroy crops and reduce yields.
4. Irrigation is necessary where there is moisture deficit for crop production to improve yield and increase food production.

5. Climate has direct effects on animals and their body physiologic functions, and the availability of water for animal consumption. It also determines the type, quantity and quality of pastures available for animal feed and indirectly determines the type of animal pests and diseases that would be prevalent in a given area.

6.0 TUTOR-MARKED ASSIGNMENT

1. Highlight the effects of temperature on crop production.
2. Explain the indirect influences of climate on crop growth.
3. Discuss the various ways in which solar radiation influences crop growth and development.
4. Moisture rather than temperature is the most important control of agriculture in the tropics. Explain.
5. Highlight the effects of temperature on crop production
6. Explain the indirect influences of climate on crop growth.

7.0 REFERENCES/FURTHER READING

Ayoade, J.O. (1983). *Introduction to Climatology for the Tropics*.
ChiChester: John Wiley and Sons.

Ayoade, J.O. (2002). *Introduction to Agro climatology*. Ibadan: Vantage
Publishers.

Bunnet, R.B. (1973). *General Geography in Diagram*. London:
Longman.

Nieuwolt, S. (1977). *Tropical Climatology: An Introduction to the
Climates of the Low Latitudes*. ChiChester: John Wiley & Sons.

Ojo, O. (1977). *The Climates of West Africa*. Ibadan: Heinemann
Educational Books.

Ojo, O. *et.al* (2001). *Fundamentals of Physical and Dynamic
Climatology*. Lagos: SEDEC Publishers.